

Installation Manual

VDR/S-VDR

Model VR-7000/VR-7000S

(VOYAGE DATA RECORDER/SIMPLIFIED VOYAGE DATA RECORDER)

SAFETY INSTRUCTIONS	i	APPENDIX 1 JIS CABLE GUIDE	AP-1
SYSTEM CONFIGURATION	iii	APPENDIX 2 CABLE FABRICATION ..	AP-2
EQUIPMENT LISTS.....	iv	APPENDIX 3 ROD TERMINALS	AP-7
1. MOUNTING.....	1-1	APPENDIX 4 DIGITAL INTERFACE..	AP-13
1.1 Data Collecting Unit VR-7010	1-1	APPENDIX 5 CODING OF THE	
1.2 Data Recording Unit (DRU)	1-3	FLOAT-FREE DRU ..	AP-31
1.3 Junction Box VR-7022F	1-15	PACKING LISTS	A-1
1.4 Remote Alarm Panel VR-7017.....	1-16	OUTLINE DRAWINGS	D-1
1.5 Microphone VR-7011	1-18	INTERCONNECTION DIAGRAMS	S-1
1.6 Waterproof Microphone VR-7012W..	1-21		
1.7 Video LAN Converter IF-7100.....	1-26		
1.8 Sensor Adapter MC-3000S/3010A/ 3020D	1-27		
1.9 Intelligent HUB HUB-3000	1-28		
1.10 Power Supply Unit PSU-011	1-29		
1.11 Switching HUB HUB-100 (Option)	1-30		
1.12 Junction Box IF-8530 (Option).....	1-30		
1.13 Junction Box IF-8540 (Option).....	1-31		
2. WIRING.....	2-1		
2.1 Data Collecting Unit VR-7010	2-2		
2.2 Data Recording Unit.....	2-10		
2.3 Junction Box VR-7022F	2-13		
2.4 Remote Alarm Panel VR-7017.....	2-15		
2.5 Microphone VR-7011	2-16		
2.6 Waterproof Microphone VR-7012W..	2-17		
2.7 Video LAN Converter IF-7100.....	2-18		
2.8 Sensor Adapters	2-25		
2.9 Intelligent HUB HUB-3000	2-37		
2.10 Power Supply Unit PSU-011	2-37		
2.11 Junction Box IF-8530 (Option).....	2-38		
2.12 IP Addresses of the Unit	2-41		
3. SETTING UP THE EQUIPMENT	3-1		
3.1 System Time Adjustment	3-1		
3.2 Recording Expiration Date of Parts.....	3-2		
3.3 DIP Switch Setting in Video LAN Converter	3-3		
3.4 How to Configure the VR-7000S.....	3-4		
3.5 Timeout Settings for Serial Input Signal....	3-5		

ECF

(Elemental Chlorine Free)

The paper used in this manual
is elemental chlorine free.

FURUNO ELECTRIC CO., LTD.

9-52 Ashihara-cho,
Nishinomiya, 662-8580, JAPAN

• FURUNO Authorized Distributor/Dealer

All rights reserved. Printed in Japan

Pub. No. IME-44850-P1

(REFU) VR-7000/7000S

A : JUL. 2014

P1 : JUL. 02, 2018





0 0 0 1 9 2 3 1 8 1 3











SAFETY INSTRUCTIONS

The installer of the equipment must read the safety instructions before attempting to install the equipment.

 DANGER	Indicates a potentially hazardous situation which, if not avoided, will result in death or serious injury.
 WARNING	Indicates a potentially hazardous situation which, if not avoided, could result in death or serious injury.
 CAUTION	Indicates a potentially hazardous situation which, if not avoided, can result in minor or moderate injury.

 Warning, Caution	 Prohibitive Action	 Mandatory Action
----------------------------------------------------------------------------------------------------	------------------------------------------------------------------------------------------------------	------------------------------------------------------------------------------------------------------

 WARNING
 Do not open the equipment unless you are well familiar with electrical circuits. Only qualified personnel should work inside the equipment.
 Turn off the power at the switchboard before beginning the installation. Fire or electrical shock can result if the power is left on.
 Be sure that the power supply is compatible with the voltage rating of the equipment. Connection of an incorrect power supply can cause fire or damage the equipment.

 WARNING
 Use only the specified power and signal cable. Fire or damage to the equipment can result if a different cable is used.
 Do not install the equipment where they may get wet from rain or water splash, or in a dusty environment. Water in the units can result in fire, electrical shock, or damage the equipment.
 Ground the equipment to prevent electrical shock and mutual interference.



CAUTION

**Use the proper fuse.**

Use of an incorrect fuse may damage the equipment.

**Observe the following compass safe distances to prevent deviation of a magnetic compass:**

Unit	Standard compass	Steering compass
Data Collecting Unit VR-7010	2.30 m	1.45 m
Remote Alarm Panel VR-7017	1.15 m	0.75 m
Microphone VR-7011	0.65 m	0.45 m
Waterproof Microphone VR-7012W	0.75 m	0.50 m
Fixed Data Recording Unit VR-7020	0.45 m	0.35 m
Float-free Data Recording Unit VR-7021F	0.80 m	0.40 m
Junction Box VR-7022F	0.80 m	0.50 m
Video LAN Converter IF-7100	1.40 m*/ 1.55 m	0.85 m*/ 1.00 m
Intelligent HUB HUB-3000	1.20 m	0.75 m
Switching HUB HUB-100	1.00 m	0.60 m
Sensor Adapter MC-3000S	2.05 m	1.35 m
Sensor Adapter MC-3010A	0.75 m	0.50 m
Sensor Adapter MC-3020D	1.05 m	0.70 m
Power Supply Unit PSU-011	0.30 m	0.30 m
Junction Box IF-8530	1.65 m	1.05 m

*: Compass safe distances for the unit whose serial number (SER.NO.) is "200001" or after.

SYSTEM CONFIGURATION

Basic configuration is shown with solid line.

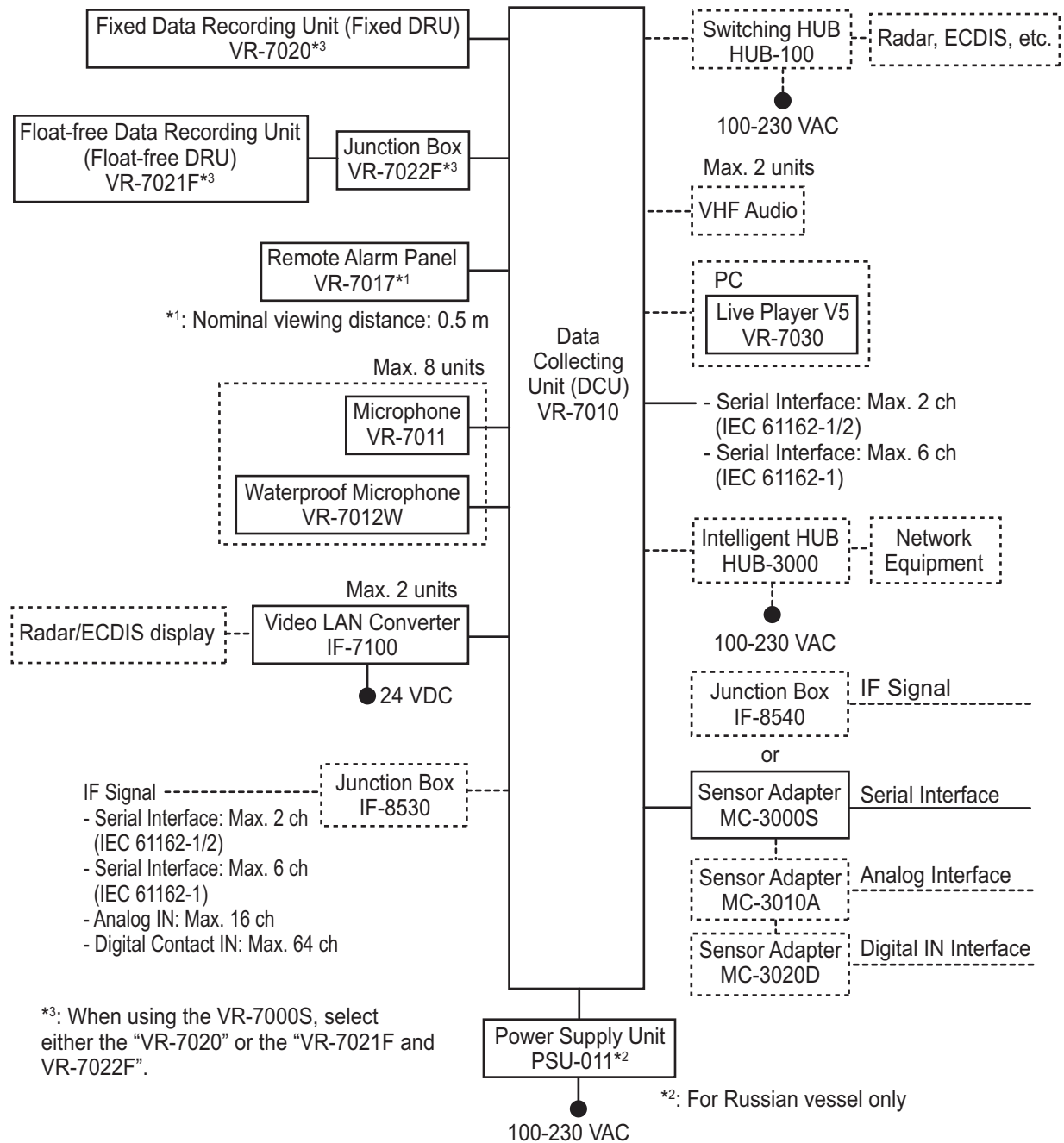

Environmental category

All units (other than VR-7021F, VR-7022F, VR-7012W and VR-7020)	Protected from the weather
VR-7021F	Portable
VR-7022F, VR-7012W and VR-7020	Exposed to the weather

EQUIPMENT LISTS

Standard Supply

Name	Type	Code No.	Qty	Remarks
Data Collecting Unit	VR-7010	-	1	
Remote Alarm Panel	VR-7017	-	1	
Fixed Data Recording Unit	VR-7020	-	1	When using the VR-7000S, select one.
Float-free Data Recording Unit	VR-7021F	-	1	
Junction Box	VR-7022F	-	1	Only when using the VR-7000S and selecting the VR-7021F
Microphone	VR-7011	-	1-8	
Waterproof Microphone	VR-7012W	-		
Video LAN Converter	IF-7100	-	0-2	
Sensor Adapter	MC-3000S	-	0-1	
Power Supply Unit	PSU-011	-	1	For Russian vessel only
Installation Materials	CP03-31701	001-013-670	1	For PSU-011
	CP24-02401	001-170-350	0-1	For MC-3000S
	CP24-03301	001-279-040	1	For VR-7010
	CP24-03401	001-279-100	1	For VR-7017
	CP24-03501	001-279-130	1-8	For VR-7011
	CP24-03601	001-279-140		For VR-7012W
	CP24-03701	001-279-120	0-2	For IF-7100
	CP24-03801	001-319-050	1	For VR-7020
	CP24-03901	001-319-060	1	For VR-7022F
CP24-04001	001-321-640	1	For VR-7021F	
Accessories	FP24-01110	000-025-269	1	For VR-7010, w/program CD and FP24-01112
Spare Parts	SP24-01101	001-279-030	1	For VR-7010
	SP24-01201	001-279-110	0-2	For IF-7100
	SP24-00701	001-170-390	0-1	For MC-3000S

Optional Supply

Name	Type	Code No.	Remarks
Microphone	VR-7011	-	
Waterproof Microphone	VR-7012W	-	
Video LAN Converter	IF-7100	-	
Junction Box	IF-8540	-	
Sensor Adapter	MC-3000S	-	Serial control unit
	MC-3010A	-	Analog IN
	MC-3010A-N	-	For IF-8540, analog IN
	MC-3020D	-	Digital IN
	MC-3020D-N	-	For IF-8540, digital IN
Intelligent HUB	HUB-3000	-	
Switching HUB	HUB-100	-	

Name	Type	Code No.	Remarks
Case Gasket	OP24-28	001-169-970	For MC-3000S
	OP24-29	001-169-960	For MC-3010A/3020D
SSD Kit	OP24-43	001-279-170	For VR-7010
Microphone Replacement Kit	OP24-44	001-279-180	For VR-7011
Installation Materials for Microphone	OP24-45	001-279-190	
IF-8530 Version-up Kit	OP24-48	001-326-380	w/IF-8530
Front Fixing Panel Kit	OP24-49	001-360-980	For VR-7017
Cable Assy.	DVI-D/D S-LINK 5M	001-132-960-10	DVI-D cable, 5 m
	DVI-D/D S-LINK 10M	001-132-980-10	DVI-D cable, 10 m
	3COX-2P-6C 5M	001-077-230-10	D-SUB cable, 5 m
	3COX-2P-6C 10M	001-077-220-10	D-SUB cable, 10 m
	MC1.5-W-L600	001-187-470-10	Between sensor adapters, 0.6 m
	MC1.5-W-L1000	001-187-480-10	Between sensor adapters, 1 m
	MC1.5-W-L2000	001-187-490-10	Between sensor adapters, 2 m
	MC1.5-W-L3000	001-187-500-10	Between sensor adapters, 3 m
	AI.14-8AI.34-6L1000	001-430-110	For installing additional unit in IF-8540
Connector Assembly	BNCX5-DSUB15-L400	001-235-030	D-SUB-BNC connector cable, 400 mm
BNC Coaxial Cable Set	CP24-01200	000-010-132	Coaxial cable (6 core) with BNC connectors, 20 m
	CP24-01210	000-010-133	Coaxial cable (6 core) with BNC connectors, 30 m
Installation Materials	CP03-28900	000-082-658	LAN cable, 10 m
	CP03-28910	000-082-659	LAN cable, 20 m
	CP03-28920	000-082-660	LAN cable, 30 m
	CP03-28930	000-084-368	LAN cable, 50 m
	CP24-02900	001-208-050	LAN cable for HUB-3000, 10 m
	CP24-02910	001-208-060	LAN cable for HUB-3000, 20 m
	CP24-02920	001-208-070	LAN cable for HUB-3000, 30 m
Spare Parts	SP03-15001	001-042-330	For HUB-100
	SP24-00801	001-235-320	For HUB-3000
	SP24-01201	001-279-160	For IF-7100
Crimping Tool	CRIMPFOX 10S	001-206-920	For ferrule
Operator's Manual	OME-44850-*	000-179-342-1*	For VR-7000/7000S
	OME-44851-*	000-179-350-1*	For Live Player V5
Instruction Manual	OME-44852-*	000-179-352-1*	For Maintenance Viewer

This page is intentionally left blank.

1. MOUNTING

NOTICE

Do not apply paint, anti-corrosive sealant or contact spray to coating or plastic parts of the equipment.

Those items contain organic solvents that can damage coating and plastic parts, especially plastic connectors.

1.1 Data Collecting Unit VR-7010

Mounting consideration

Select a mounting location, keeping in mind the following points:

- Locate the unit away from heat sources.
- Select a location where the shock and vibration are minimal.
- Locate the unit away from places subject to water splash and rain.
- Make the maintenance space shown in the outline drawing for maintenance and checking purpose.
- A magnetic compass will be affected if the unit is placed too close to the magnetic compass. Observe the compass safe distances at the front of this manual to prevent interference to a magnetic compass.
- Select a mounting location considering the length of the cables to be connected to this unit.

The cables connected the units shown below should be 50 m or less.

- Fixed DRU
- Float-free DRU
- Microphone
- Waterproof microphone
- Remote alarm panel
- Select a location where the surface is flat. If it is not flat, insert a number of washers between the unit and the mounting location as necessary.
- Select a location that is strong enough to support the weight of the unit.
- The cable entrance of the unit should face downward.

1. MOUNTING

Mounting

Install the data collecting unit (DCU) on a bulkhead.

1. Fasten the unit with four M10 bolts or $\phi 10$ coach bolts (local supply).

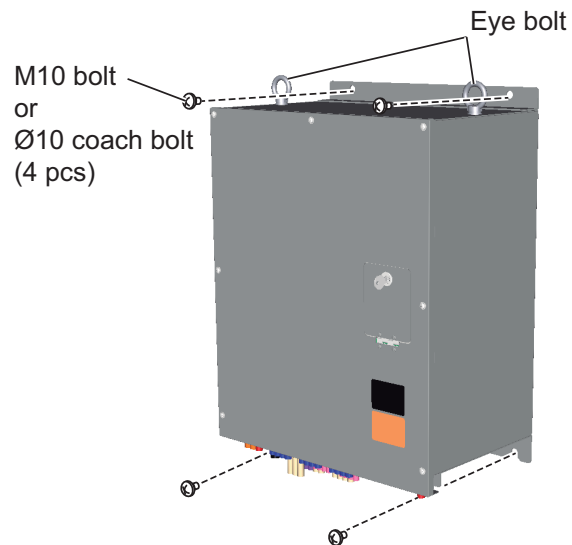

2. Two eye bolts are attached at the top of the unit to hoist the unit onboard. Remove them after the installation.
3. Attach two cosmetic caps (supplied) to eye bolt holes.

1.2 Data Recording Unit (DRU)

1.2.1 Fixed data recording unit VR-7020

The fixed DRU shall be sited in the vicinity of the bridge on the external deck area of the vessel so as to maximize the probability of its survival and recovery following an incident.

VR-7000S systems have either a fixed data recording unit (VR-7020) or a float-free data recording unit (VR-7021F). For configurations that use the VR-7021F, see section 1.2.2.

Mounting consideration

Select a mounting location, keeping in mind the following points:

- Select the mounting location considering the facilitation of underwater removal and retrieval by both divers and ROVs. There should be a clear unobstructed space in the vicinity of the capsule to allow an ROV or diver to work.
- Locate the unit as near to the center line of the ship as possible.
- Locate the unit away from fuel or other potential fire sources.
- Locate the unit away from probable sources of the mechanical damage.
- Make the maintenance space for maintenance and checking purpose.

Mounting

To install the fixed DRU, do the following:

1. Verify that the fixed DRU mounting base lines up with the hull mounting holes. Refer to the figure on the next page for the fixed DRU mounting base template pattern.
2. Ensure the paint around the bottom of the mounting holes on the fixed DRU and hull mounting brackets is removed.
3. Apply the supplied silicone rubber (S-8400W) around the mounting holes on the fixed DRU and hull mounting brackets.
4. Install three lock washers (supplied).
5. Insert bolts through the hull mounting brackets.
6. Fix the fixed DRU with the supplied installation materials.
See the figure "Hull Grounding Technique" on the next page.

1. MOUNTING

"Hull Ground Technique" and "Mounting Base Template Pattern"

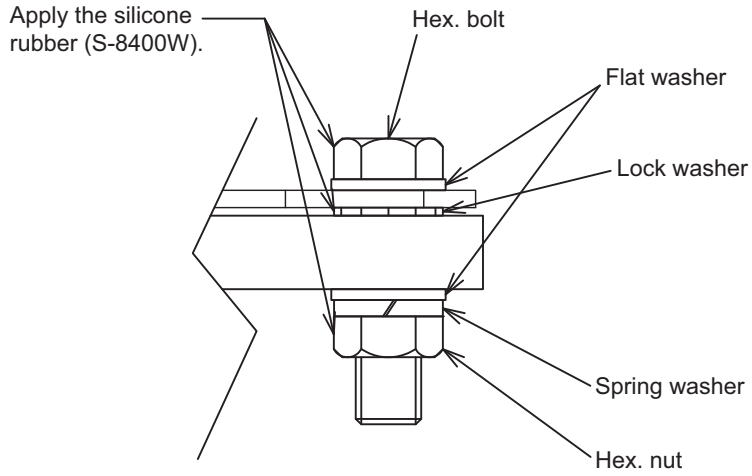

Hull Grounding Technique

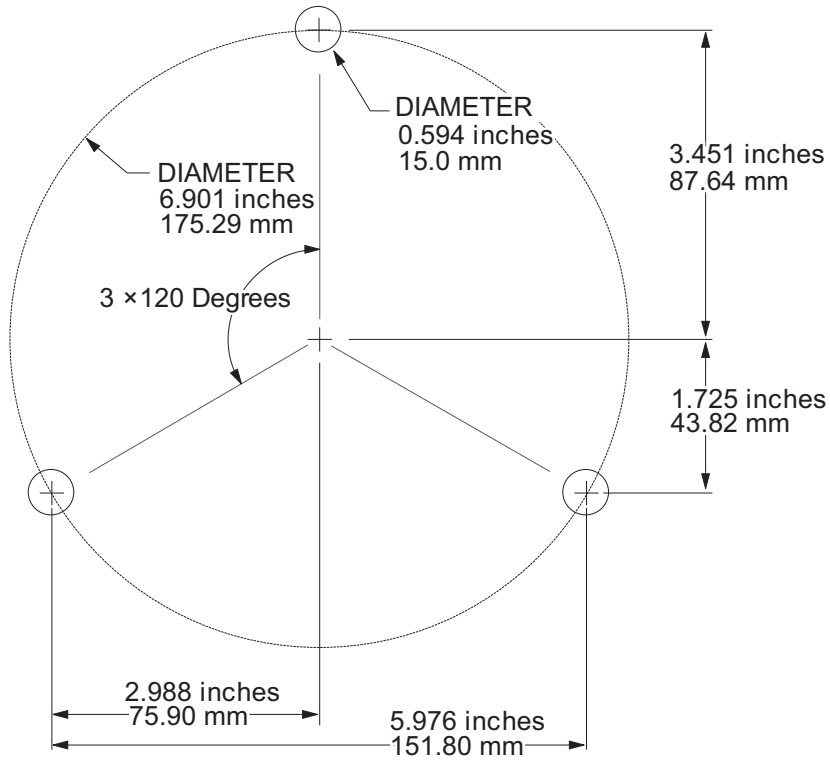

Mounting Base Template Pattern

1.2.2 Float-free data recording unit VR-7021F

VR-7000S systems have either a fixed data recording unit (VR-7020) or a float-free data recording unit (VR-7021F). For configurations that use the VR-7020, see section 1.2.1.

Note: The IMO obliges that VDR-equipped ships must carry a float-free DRU. The following is an excerpt from the regulation. Observe the following location/installation conditions.

- The float-free DRU must be installed in the vicinity of the navigation bridge, i.e. on the wings of the navigation bridge. Access via vertical ladder should not be accepted. A location on the top of the wheelhouse may be accepted to fulfill the requirement if accessible by stairs.

Mounting consideration

Select a mounting location, keeping in mind the following points:

- The float-free DRU should, with greatest possible probability, float-free and avoid being caught in railings, superstructure, etc., if the ship sinks.
- The float-free DRU should be located so that it may be easily released manually and brought to the survival craft by one person. It should therefore not be located in a radar mast or any other places which can only be reached by vertical ladder.
- Fix the float-free DRU vertically on the bulkhead or hand-rail so that the cable entrance faces downward. Ensure that the steel hull or plate where the bracket is mounted is completely flat. If it is uneven, the capsule may not make good contact with the docking module.
- Confirm that a buoyant lanyard is attached to the capsule correctly. The buoyant lanyard (for tethering to life craft) is attached to the capsule of the float-free DRU. The buoyant lanyard must be attached to the capsule correctly to prevent its being trapped in the ship's structure when the capsule is released.
- The float-free DRU should be marked with the ship's call sign, serial number, MMSI number (if applicable), and 15 Hex ID before installation.
- The cable between the float-free DRU and junction box (VR-7022F) should be as short as possible.
- The cover of the float-free DRU should be attached correctly. If the cover is not attached correctly, the cover and capsule may drop out of the bracket due to wind and/or vibration. For how to attach the cover, see "How to attach the cover" on page 1-13.

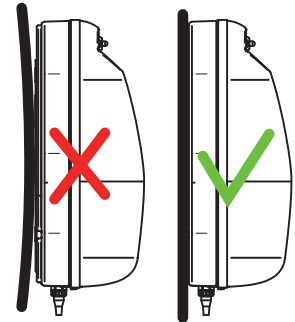

1. MOUNTING

- Ground the unit by connecting the ground plate to the ship's body with the hex. bolt.
- Apply the supplied silicone grease between the docking module and storage module to prevent water from entering (see the figure at step 3 on page 1-10).
The silicone grease is supplied with the float-free DRU. The grease is marked as "Item no.88237 Tron-40VDR". After applying the silicone grease, do not release the capsule from the bracket other than the maintenance. If you release the capsule, apply the silicone grease again when reattach it.

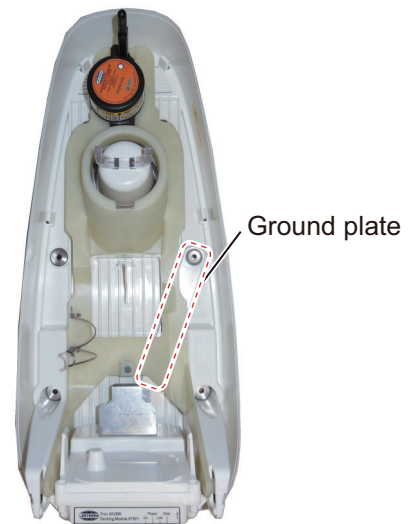

- Do not remove the vinyl protective cover on the cable connector until you connect the cable to the float-free DRU.
When the float-free DRU serial number is "20-0001" or later, the float-free DRU cable is separated from the capsule and the vinyl protective cover is attached to the cable connector. If the connector is damaged or worn, a communication error may occur. Therefore, keep the vinyl protective cover attached until you can connect the cable to the float-free DRU.



- Do not bend and/or twist the cable excessively to secure the cable. Ensure a minimum bend radius of 80 mm.

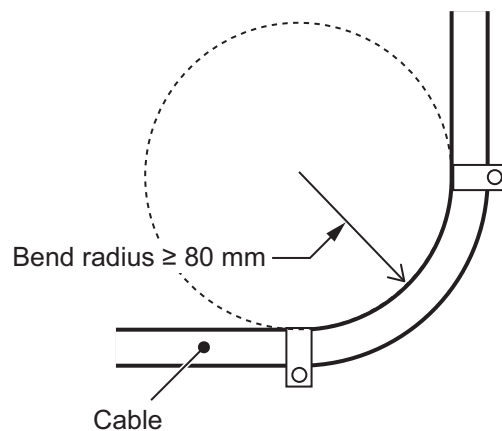

- Adjust the cable length so that the cable routes vertically to the float-free DRU and horizontally to the junction box. See the example figure to the right for reference.

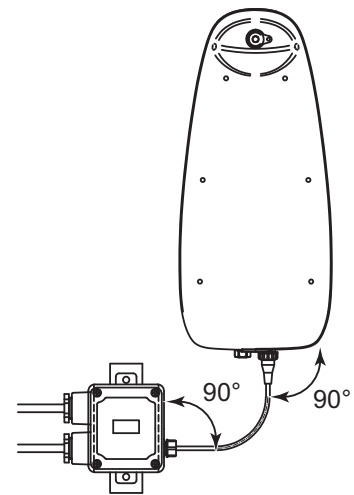

- As shown in the following figure, fasten the bracket and the junction box (VR-7022F) to the steel plate, then fasten the steel plate to the ship's hull. For details, see the outline drawing. If there is not enough space on the steel plate to install the junction box there, install only the bracket on the steel plate. The reason for installing the bracket on the steel plate is to prevent water from leaking into the bracket from the rear of the bracket.
 - The thickness of the steel plate should be 6 mm.
 - Install the bracket on a flat steel plate flush with the steel plate.
 - The bending radius for the cable that binds the capsule to the junction box should be 80 mm or more.
 - Pass the ground from the bracket through the steel plate and connect it to the ship's hull.
 - The cable gland on the junction box can be horizontal or vertical.

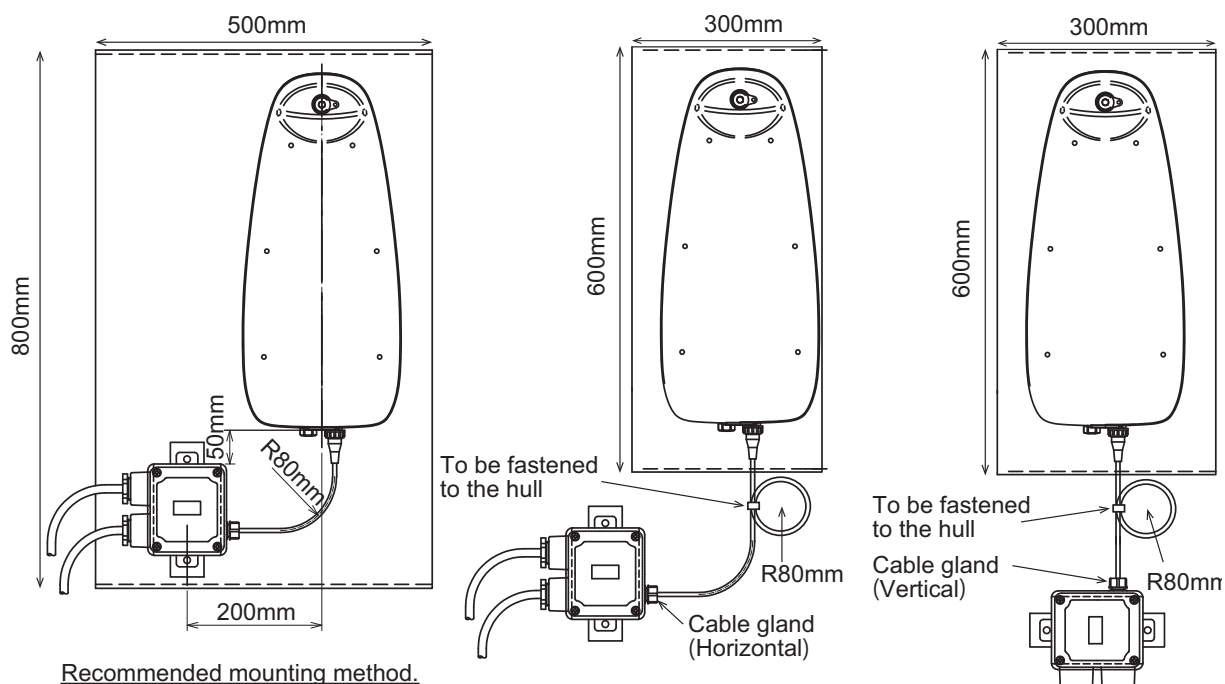

Recommended mounting method.

Mounting method when there is not enough space on the steel plate to install the junction box there.

1. MOUNTING

- Select a place where interference from other radio equipment is minimal.
The float-free DRU is compliant with IEC 60945. However, some radio equipment (ex. S-band radar antennas) may create excessive electrical fields, which are larger than the IEC 60945 test standards. These large electrical fields can interrupt the radio communication between the storage module and docking module or result in the malfunction of the equipment. To avoid interference from other equipment, keep to the following guidelines:
 - Select a place where the float-free DRU is not exposed to the RF signal from the S-band radar antennas.
Generally, a place where the radar antenna is not within the visual field of the float-free DRU (ex. wing opposite to the radar mast) is recommended.
 - Locate the unit 5 m or more away from a VHF antenna.
The float-free DRU is designed to resist electrical fields of 100 V/m in the VHF frequency range 156 to 165 MHz. In other frequency ranges between 150 kHz to 2 GHz, the float-free DRU resists electrical fields of 10 V/m. Generally, a VHF antenna creates an electrical field of 10 V/m at distance of 3 meters in the antenna lobe. Therefore, it is recommended to locate the unit 5 m or more away from a VHF antenna.

The following picture indicates the recommended and not recommended installation location.

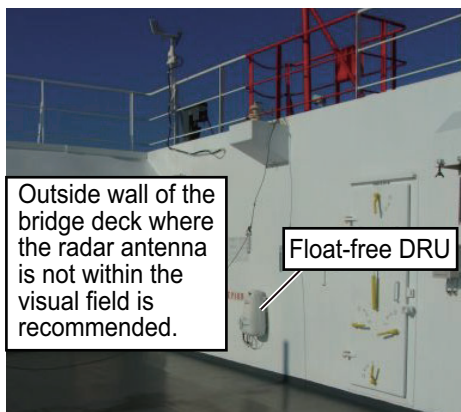

Recommended installation location

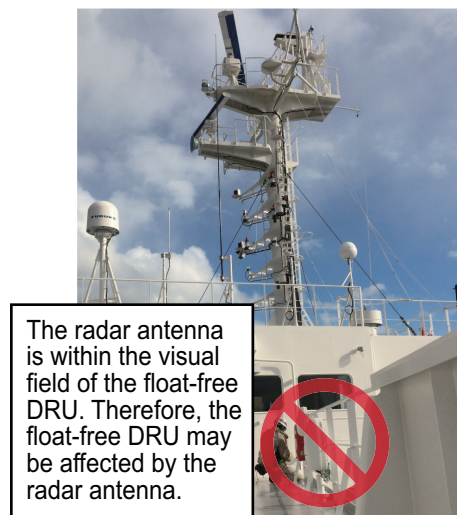

Not recommended installation location

(The float-free DRU is subject to radar antenna interference.)

- Outdoor cables for float-free DRU and junction box should be short as possible. If long outdoor cables are required, prepare a steel pipe and run the cable through the pipe to protect the cables from interfering with other radio equipment.
- Before securing the float-free DRU, run a ping test at the planned installation location, to confirm that the float-free DRU is subject to interference from other equipment. For the ping test procedure, see the following procedure.

Ping test

Before securing the float-free DRU, do as follows to run the ping test. The ping test is required to check that the float-free DRU is not subject to interference from other equipment.

1. Set the IP address and subnet mask of the PC as follows:
 - IP address: 10.0.0.101
 - Subnet mask: 255.0.0.0

Note: The IP address of the float-free DRU is “10.0.0.150”.

2. Check that all radars are in standby mode and other antennas are not transmitting any signal.
3. Connect the float-free DRU to the PC and power (24 VDC), referring the following figure.

Note: The float-free DRU cable may be different, depending on the time of manufacture. Therefore, wire colors that connect to the #3 and #4 pins in the VR-7022F depend on the cable specifications.

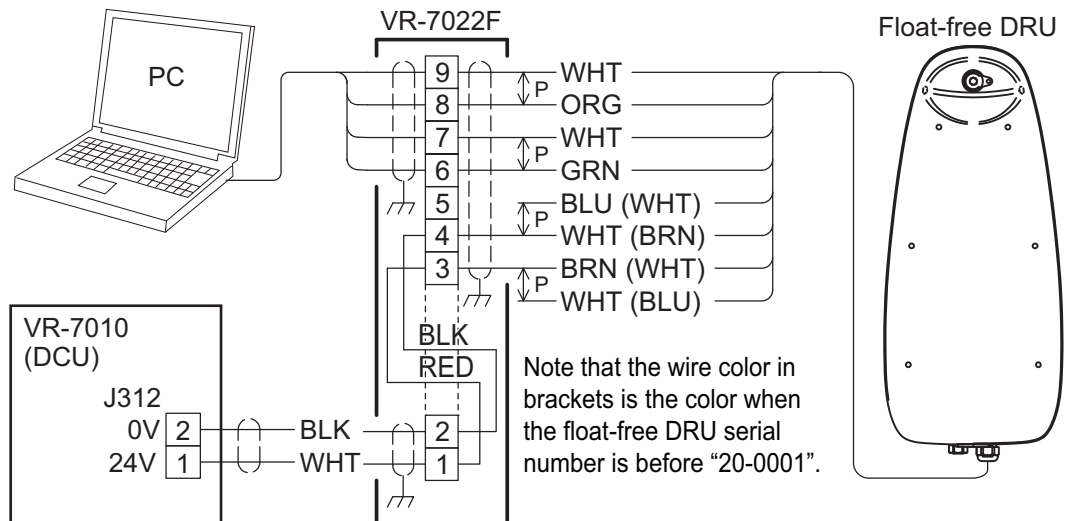

4. Turn the DCU on to supply the power to the float-free DRU.
5. Wait approx. 20 minutes until the float-free DRU starts up.
6. Activate the command prompt on the PC.
7. Enter “ping 10.0.0.150” on the command prompt.
8. Check the test result.
When the response from the float-free DRU is received successfully and there is no package lost, go to the next step. If the response is not received or some packages are lost, check the connection and that the power is supplied to the float-free DRU, then retry the ping test. If the failure is not rectified, there is a problem in the LAN cable. Replace the LAN cable between the PC and junction box.
9. Enter “ping -l 45000 -n 40 -w 100 10.0.0.150” on the command prompt.
This commands the PC to request 40 packages of 45 KB and simulates high data load.
10. Check the test result.
When the response from the float-free DRU is received successfully and there is no package lost, go to the next step. If three packages or more are lost, there may be connection error. Check the connection and retry the ping test.
11. Turn on either one of the radio equipment and start transmitting (ex. S-band radar).
12. Enter “ping -l 45000 -n 40 -w 100 10.0.0.150” on the command prompt.
13. Check the test result.
When the response from the float-free DRU is received successfully and there is no package lost, the float-free DRU is not interfered with the other equipment. If the response is not received or some packages are lost, the equipment turned on at step 11 is causing the communication error. Change the installation location and retry the ping test.

1. MOUNTING

- Repeat step 11 to step 13 to check that there is no interference with other equipment.

Mounting

- Release the safety clip and remove the cover and capsule from the mounting bracket.

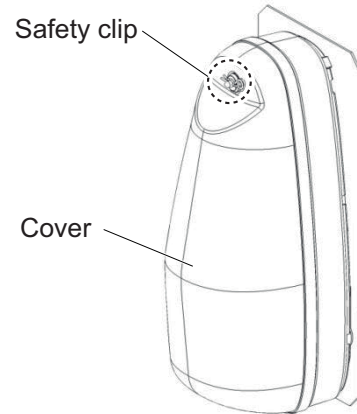

- Fix the mounting bracket with the supplied installation materials.

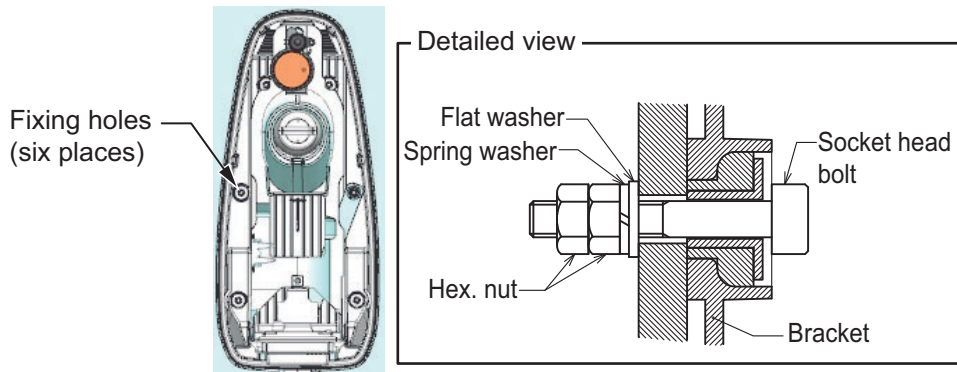

- Apply the supplied silicone grease between the docking module and storage module, then reattach the capsule.

The silicone grease is supplied with the float-free DRU. The grease is marked as "Item no.88237 Tron-40VDR".

Note: Do not use the silicone grease other than the supplied silicone grease. The silicone grease is used for the maintenance of the float-free DRU, so make a space for storage around the DCU and store the grease on the vessel.

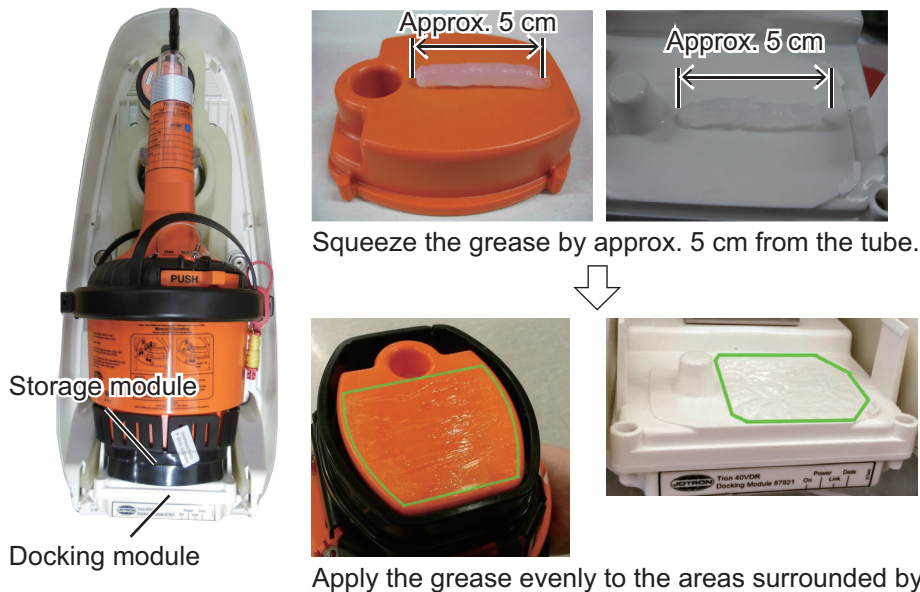

4. Confirm the following points;

- There is no space or foreign material between the storage module and docking module.
- The notch on the docking module is placed in the groove of the storage module.

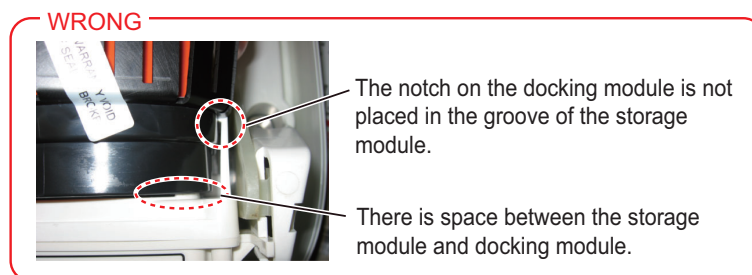
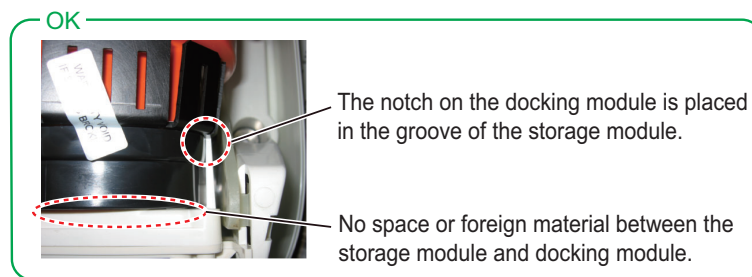

- The antenna of the capsule is placed in the antenna holder correctly.

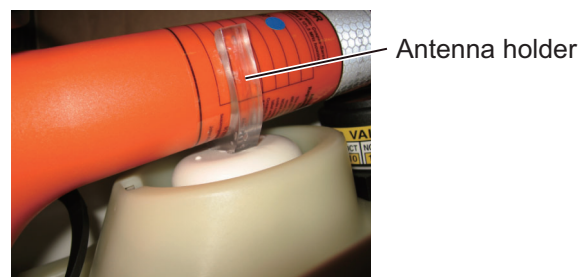

5. Reattach the cover to the bracket correctly, referring to "How to attach the cover" on page 1-13.

- Note:** If the cover is not attached correctly, the cover and capsule may drop out of the bracket due to wind and/or vibration.

Recording the expiration date of the battery and hydrostatic release unit

After installing the float-free DRU, confirm the expiration date of the battery (inside the float-free DRU (capsule)) and hydrostatic release unit, then record them to the table in section 3.2. The expiration date is recorded during coding (see page AP-31).

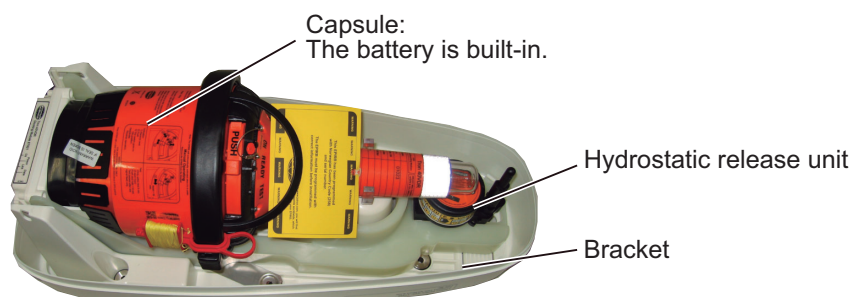
• **Battery in the float-free DRU**

The expiration date of the battery is indicated on the sticker attached to the side of the capsule. According to the expiration date, the numbers on the sticker are cut out

1. MOUNTING

or filled with a permanent marker. For example, when the expiration date is April 2019, “2019” and “4” on the sticker are cut out or filled with a permanent marker. After confirming the expiration date, record it to the table in section 3.2.

Example: When the expiration date is April 2019.

The expiration date is indicated on this sticker.

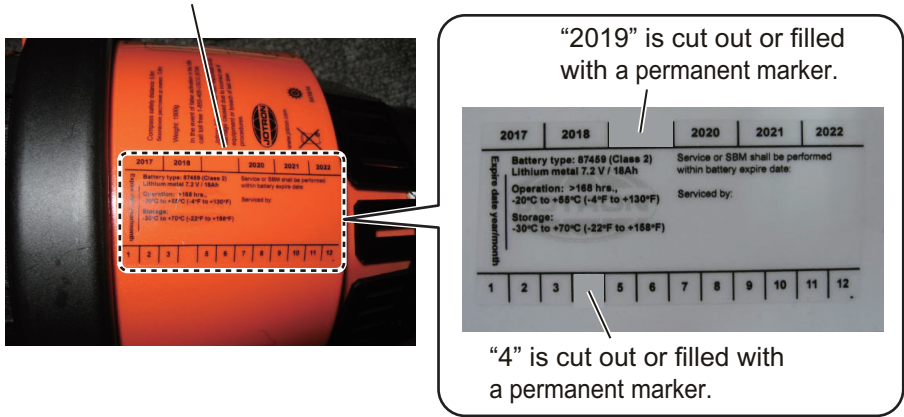

- **Hydrostatic release unit**

The expiration date of the hydrostatic release unit is indicated on the sticker attached to the side of the unit or the sticker on the side of the bracket. For the sticker attached to the side of the unit, the numbers on the sticker are cut out or filled with a permanent marker according to the expiration date. For example, when the expiration date is June 2016, the numbers below the “2016” and “JUN” on the sticker are cut out or filled with a permanent marker.

Example: When the expiration date is June 2016.



The number below “2016” is cut out or filled with a permanent marker.

The number below “JUN” is cut out or filled with a permanent marker.

For the sticker attached to the side of the bracket, the expiration date is recorded in the field shown below.

After confirming the expiration date, record it to the table in section 3.2.

Note: If the expiration date is not recorded on the sticker, record it on the sticker, referring to the sticker attached to the side of the hydrostatic released unit.

The expiration date is inscribed here.

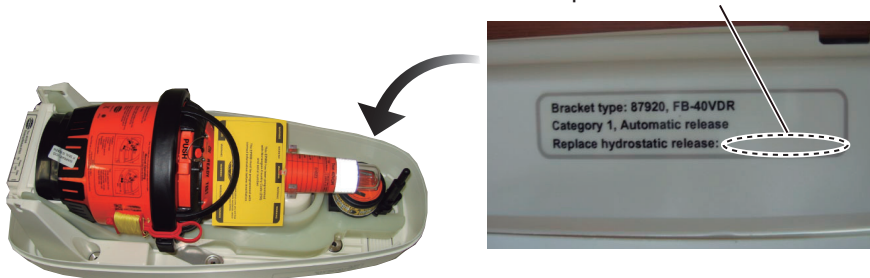

How to attach the cover

Attach the cover to the bracket as follows. If the cover is not attached correctly, the cover and capsule may drop out of the bracket due to wind and/or vibration.

1. Fit the notch on the cover with the ridge on the bracket.

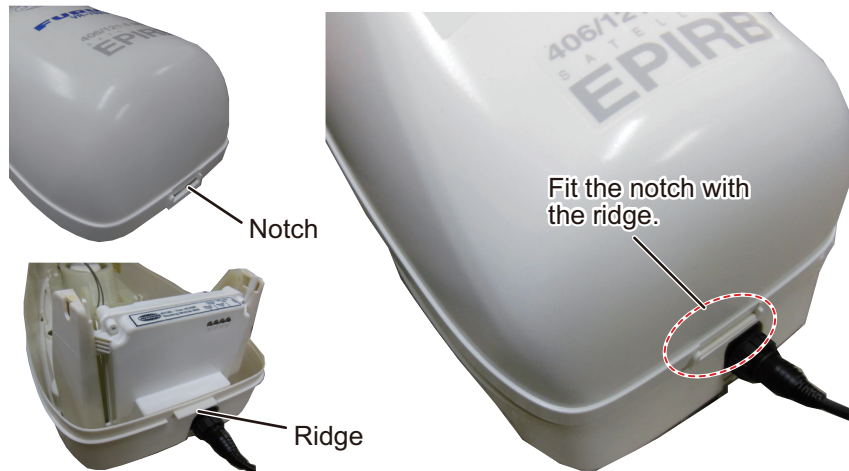

2. There is a groove alongside the cover that has to be aligned and fit around the tongue on the bracket. Align the tongue on the bracket and groove alongside the cover.



3. Attach the cap to the hole at the top of the cover, then insert the safety clip. **Note:** Make sure the safety clip is mounted correctly, referring to the following figure.

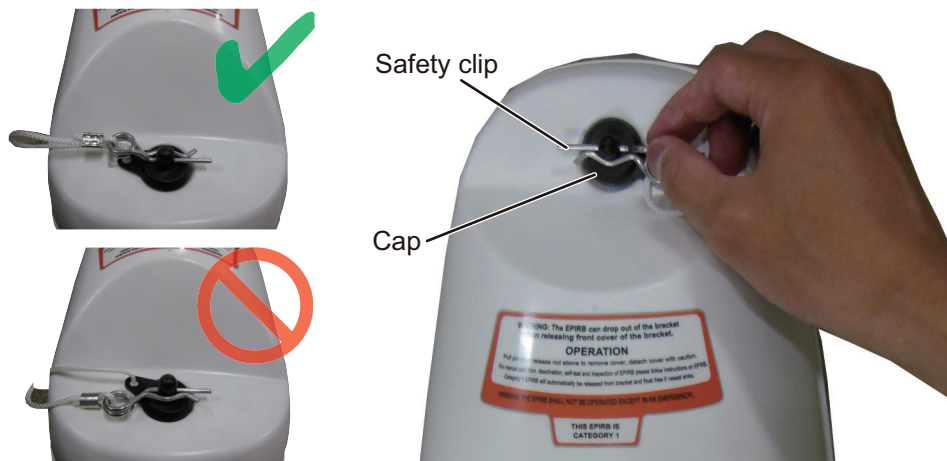

1. MOUNTING

Attaching the SOS placard

The SOS placard is supplied with the float-free DRU. The SOS placard provides the procedure for how to remove the capsule from the float-free DRU manually. Attach the SOS placard to a conspicuous location, such as a bulkhead or handrail, near the float-free DRU.

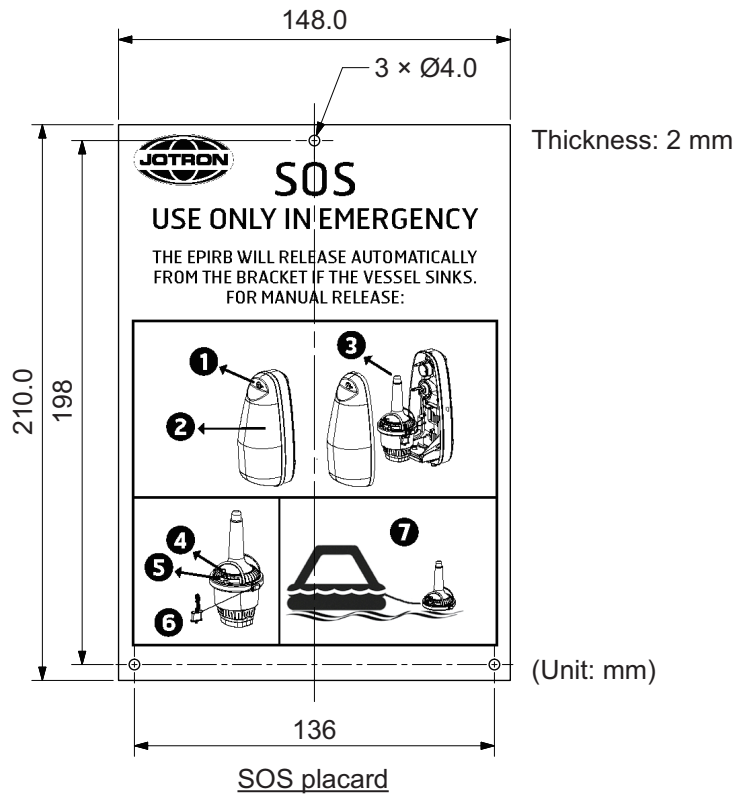

1.3 Junction Box VR-7022F

For configurations that use the VR-7020, the installation procedures outlined in this section and section 2.3 are not required.

Mounting considerations

Select a mounting location, keeping in mind the following points:

- Locate the unit away from heat sources.
- Select a location where the shock and vibration are minimal.
- Make the maintenance space shown in the outline drawing for maintenance and checking purpose.
- A magnetic compass will be affected if the unit is placed too close to the magnetic compass. Observe the compass safe distances at the front of this manual to prevent interference to a magnetic compass.
- Select a mounting location considering the length of the cables to be connected to this unit.
- After fastening the unit, apply the supplied silicone sealant (KE-347-W-100) to the fixing holes to prevent corrosion.

Mounting

Fasten the unit with two bolts (M8, local supply) on a bulkhead. The cable gland on the junction box can be horizontal or vertical.

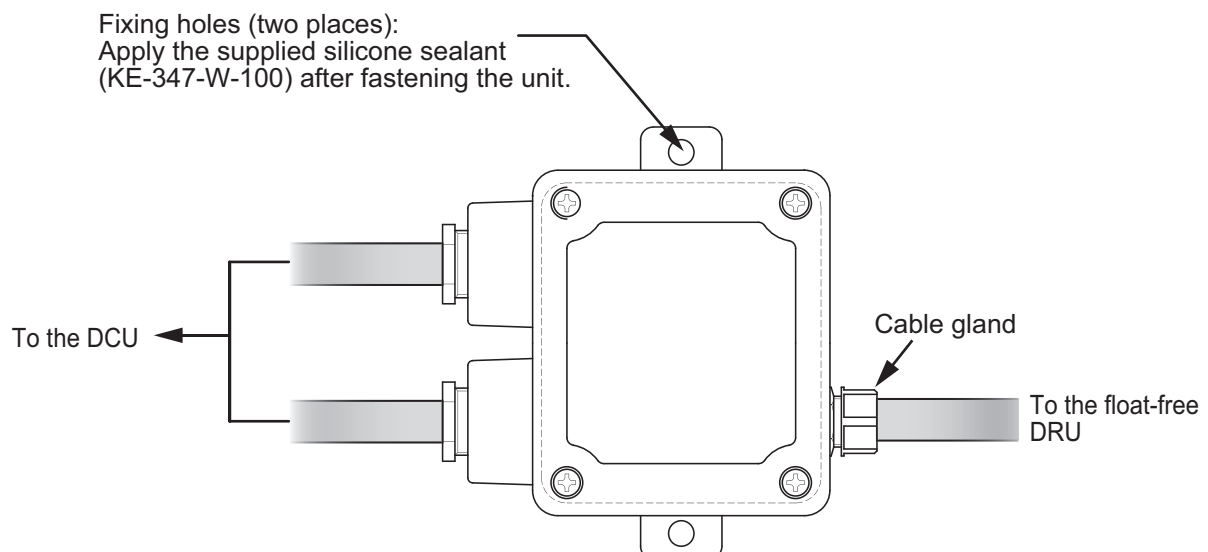

1.4 Remote Alarm Panel VR-7017

Mounting considerations

Select a mounting location, keeping in mind the following points:

- Locate the unit away from heat sources.
- Select a location where the shock and vibration are minimal.
- Locate the unit away from places subject to water splash and rain.
- Make the maintenance space shown in the outline drawing for maintenance and checking purpose.
- A magnetic compass will be affected if the unit is placed too close to the magnetic compass. Observe the compass safe distances at the front of this manual to prevent interference to a magnetic compass.
- Select a mounting location considering the length of the cable to be connected to this unit.

Mounting

The remote alarm panel is designed to be flush-mounted in a console.

1. Make a mounting hole in the mounting location and prepare four pilot holes, referring to the outline drawing at the back of this manual.
2. Remove two binding screws (M3x6) to detach the back cover of the unit.

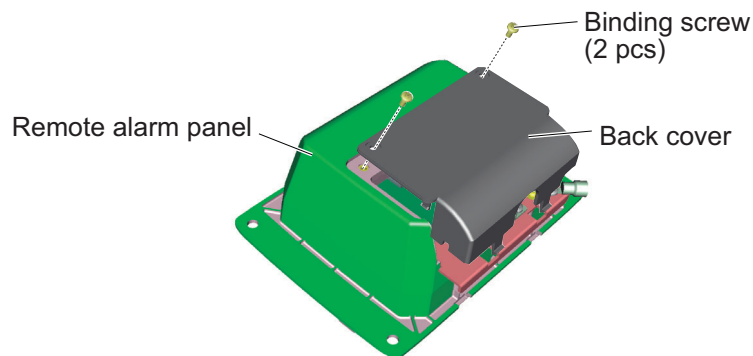

3. Pass the cable through the mounting hole.
4. Connect the cable to the unit. For details of connection and wiring, see section 2.4 and interconnection diagram at the back of this manual.
5. After wiring, reattach the back cover.
Set the tabs on the back cover to the holes in the unit, then fix it with the screws.

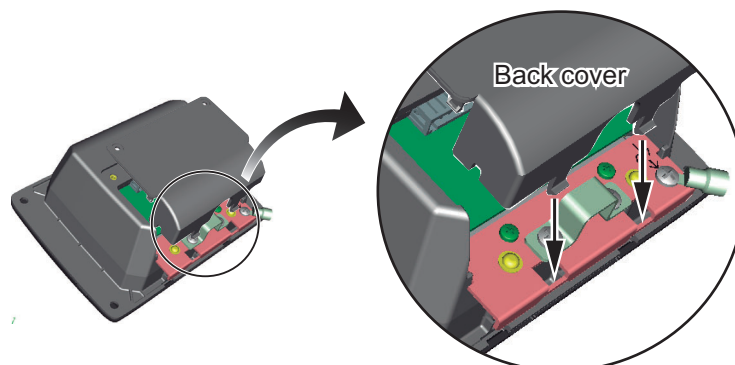

6. Remove the front cover of the unit by hand.



7. Set the unit to the mounting hole, then fix the unit with four self-tapping screws (supplied).

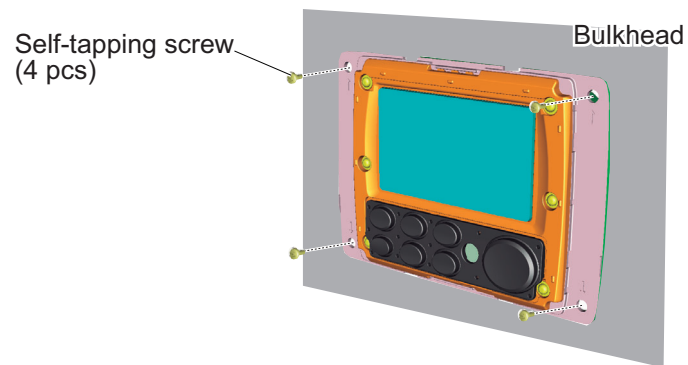

8. Attach the front cover to the unit.

1.5 Microphone VR-7011

A maximum of eight microphones (waterproof, non-waterproof) can be connected to the DCU.

Audio coverage: Hemisphere area of 3.5 m approx. in radius

Mounting considerations

Select a mounting location, keeping in mind the following points:

- Locate the unit away from heat sources.
- Select a location where the shock and vibration are minimal.
- Locate the unit away from places subject to water splash and rain.
- Make the maintenance space shown in the outline drawing for maintenance and checking purpose.
- A magnetic compass will be affected if the unit is placed too close to the magnetic compass. Observe the compass safe distances at the front of this manual to prevent interference to a magnetic compass.
- Select a mounting location considering the length of the cable to be connected to this unit.
- Locate away from noise sources, such as fans, motors, and loudspeakers (1 m or more from air duct).
- Fix the cable to the bulkhead or overhead with a cable clamp, etc. to keep noise to a minimum.
- Microphones are mounted in the places shown below to pick up voice communications.
 - Center line conning
 - Bridge wings (if steering gear is installed)
 - Main radar
 - Chart table
 - Helmsstand
 - Radio room

Mounting

The microphone is designed to be flush-mounted.

1. Make a mounting hole in the mounting location and prepare four pilot holes, referring to the outline drawing at the back of this manual.
2. Remove four binding screws to detach the back cover of the unit.

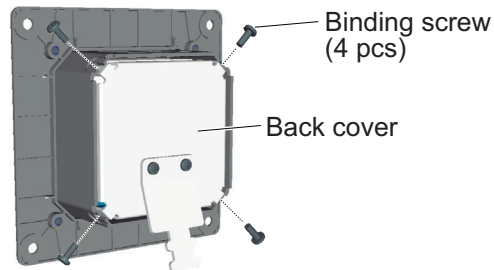

3. Pass the cable through the mounting hole made at step 1.
4. Connect the cable to the unit. For details of connection and wiring, section 2.5 and interconnection diagram at the back of this manual.
5. After wiring, attach the back cover to the unit with four binding screws.
6. Set the unit to the mounting hole, then fix the unit with four self-tapping screws (supplied).

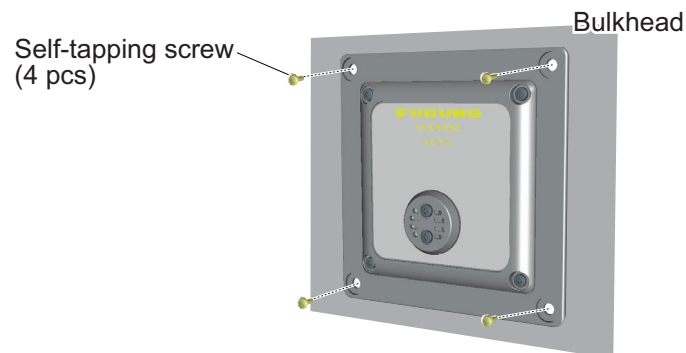

1. MOUNTING

How to replace the VR-5011 with the VR-7011

The mounting holes of the Microphone VR-5011 (for previous models) can be reused when replacing the VR-5011 with the VR-7011, using the optional microphone replacement kit OP24-44.

1. Remove four screws to remove the fixing plate from the VR-7011.

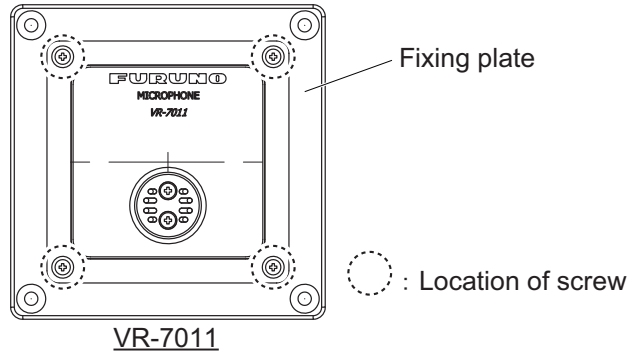

2. See the outline drawing below to resize the mounting hole for the VR-5011.

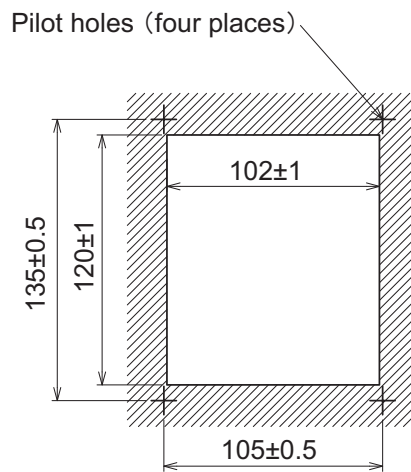

3. Fasten the front fixing panel (option) to the mounting hole with four self-tapping screws ($\phi 4 \times 16$).
The screws to fasten the front fixing panel are supplied with the VR-7011.
4. Fasten the VR-7011 to the front fixing panel with the screws removed at step 1.

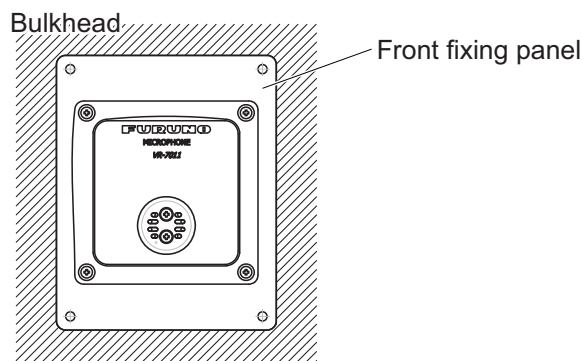

1.6 Waterproof Microphone VR-7012W

A maximum of eight microphones (waterproof, non-waterproof) can be connected to the DCU.

Audio coverage: Hemisphere area of 3.5 m approx. in radius

Mounting considerations

Select a mounting location, keeping in mind the following points:

- Locate the unit away from heat sources.
- Select a location where the shock and vibration are minimal.
- Make the maintenance space shown in the outline drawing for maintenance and checking purpose.
- A magnetic compass will be affected if the unit is placed too close to the magnetic compass. Observe the compass safe distances at the front of this manual to prevent interference to a magnetic compass.
- Select a mounting location considering the length of the cable to be connected to this unit.
- Locate away from noise sources, such as fans, motors, and loudspeakers (1 m or more from air duct).
- Fasten the cable to the bulkhead or overhead with a cable clamp, etc. to keep noise to a minimum.
- Locate the unit away from places subject to radar radio wave of a radar antenna. The noise may be added to the recording data because of the interference from the radio wave of a radar antenna.

Mounting

According to the shipment time, the cable entrance may be the super gland or SC lock.

Mounting instruction and installation materials depend on the figure of the cable entrance.

When the cable entrance is the SC lock

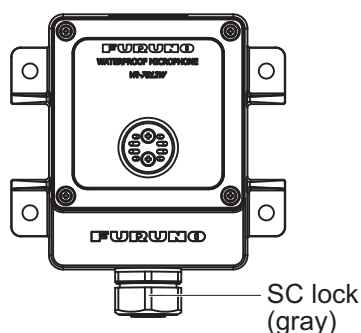

Supplied installation materials:

- Self-tapping screws (4 pcs)
- Sealing insert (1 pcs)

When the cable entrance is the super gland

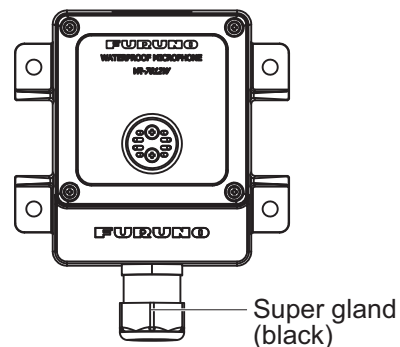

Supplied installation materials:

- Self-tapping screws (4 pcs)
- Cable tie (1 pcs)

1. MOUNTING

When the cable entrance is the SC lock

1. Remove four binding screws to detach the front panel from the waterproof cover.

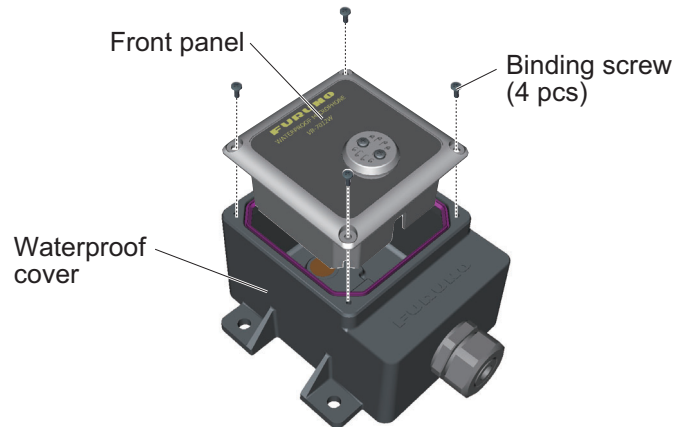

2. Fasten the waterproof cover to the mounting location with four self-tapping screws (supplied).

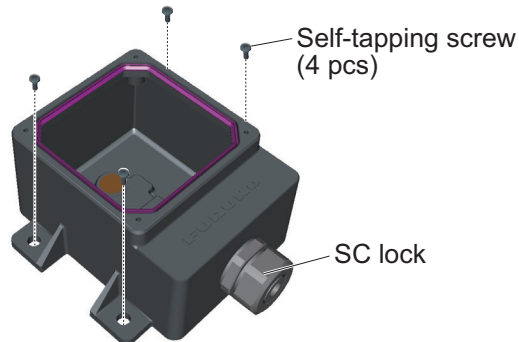

3. Remove the nut and sealing insert from the SC lock.

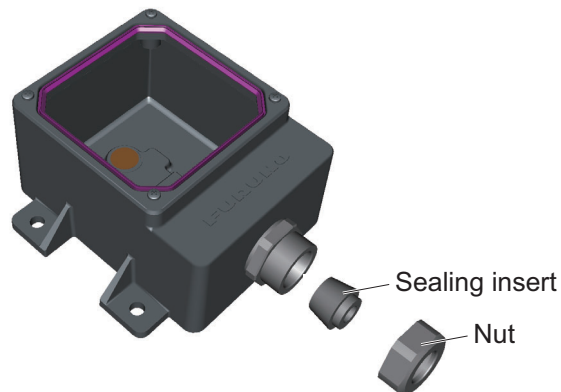

4. Fabricate the cable.

The SC lock can clamp the cable at the sheath or cable jacket. Select where to clamp the cable, then fabricate the cable.

The method of fabrication changes with the clamping location.

When the sheath is fixed with the SC lock

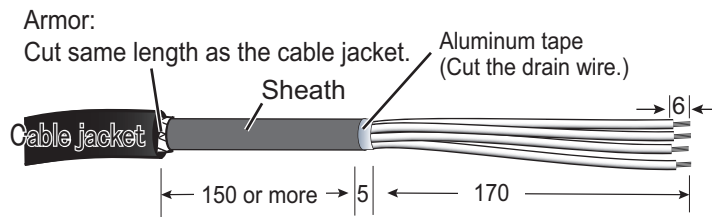

When the cable jacket is fixed with the SC lock

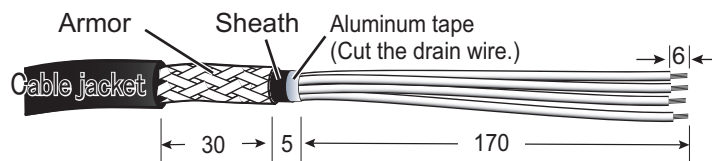

5. Pass the sealing insert and nut onto the cable, then pass the cable through the cable entrance.

According to the cable clamp location, select the sealing insert.

- When the sheath is fixed with the SC lock:
Use the sealing insert (type: SC-4M) removed at step 3. Discard the sealing nut supplied with the installation materials.
- When the cable jacket is fixed with the SC lock:
Use the sealing insert (type: SC-4B) supplied with the installation materials. Discard the sealing nut removed at step 3.

6. Wrap the vinyl tape around the cable (see figure below).

When the sheath is fixed with the SC lock

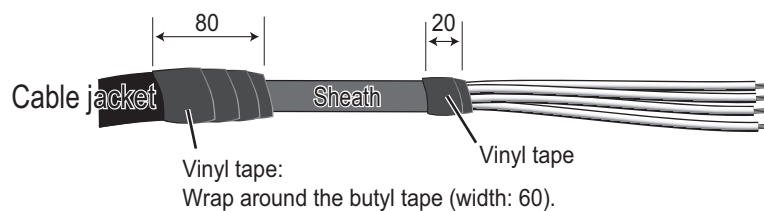

When the cable jacket is fixed with the SC lock

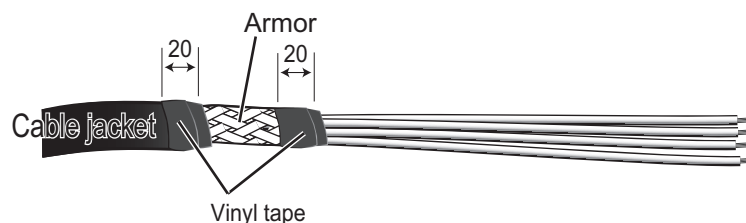

7. Connect the cable to the unit. For details, see section 2.6 and the interconnection diagram at the back of this manual.

1. MOUNTING

- After wiring, tighten the nut according to the information in the table below.

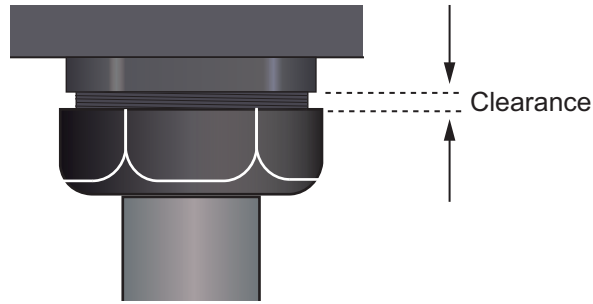

Clamp location	Clearance	Torque
Cable jacket	2.0 mm	2.0 - 2.5 Nm
Sheath	1.5 mm	2.0 - 2.5 Nm

- Fasten the front panel to the waterproof cover with the four binding screws removed at step 1.

Note 1: Before fixing the front panel, make sure the waterproofing gasket is correctly seated in the groove in the waterproof cover.

Note 2: Take care not to bend or pinch the cable.

When the cable entrance is the super gland

- Remove four binding screws to detach the front panel from the waterproof cover.

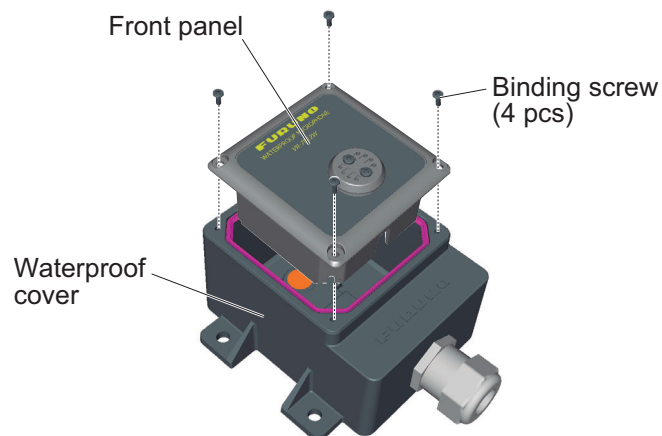

- Fasten the waterproof cover to the mounting location with four self-tapping screws (supplied).

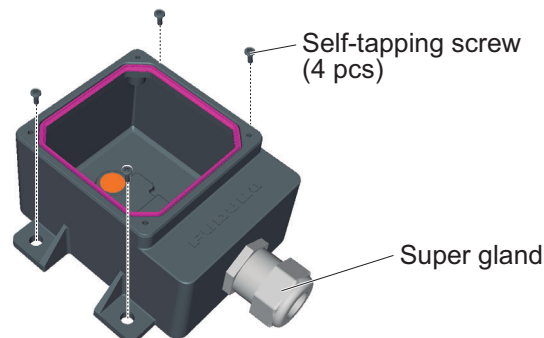

- Remove the nut from the super gland.

- Fabricate the cable.

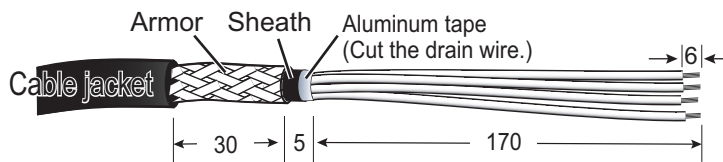

- Pass the cable through the nut and cable entrance.

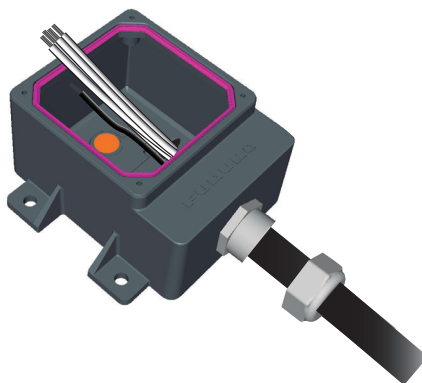

- Wrap the vinyl tape and cable tie around the cable (see the figure below).

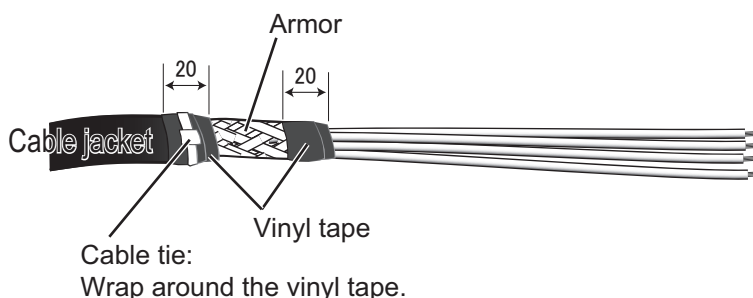

- Connect the cable to the unit. For details, see section 2.6 and the interconnection diagram at the back of this manual.
- After wiring, fasten the nut so the clearance between it and the gland is 3 mm or less (see figure below).

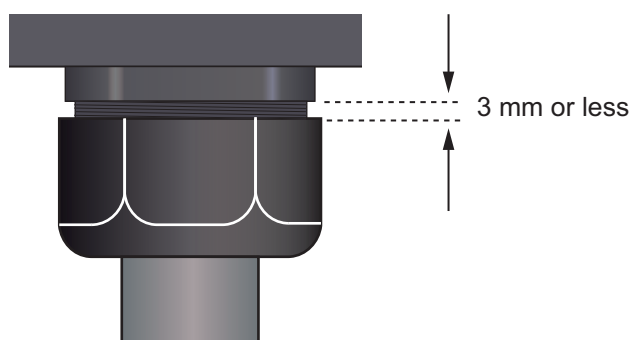

- Fasten the front panel to the waterproof cover with the four binding screws removed at step 1.

Note 1: Before fixing the front panel, make sure the waterproofing gasket is correctly seated in the groove in the waterproof cover.

Note 2: Take care not to bend or pinch the cable.

1.7 Video LAN Converter IF-7100

Mounting considerations

Select a mounting location, keeping in mind the following points:

- Locate the unit away from heat sources.
- Select a location where the shock and vibration are minimal.
- Locate the unit away from places subject to water splash and rain.
- Make the maintenance space shown in the outline drawing for maintenance and checking purpose.
- A magnetic compass will be affected if the unit is placed too close to the magnetic compass. Observe the compass safe distances at the front of this manual to prevent interference to a magnetic compass.
- Select a mounting location considering the length of the cables to be connected to this unit.
- For the bulkhead mounting, the cable entrance of the unit should face downward.
- Select the cable length of the DVI cable considering the resolution of the radar/EC-DIS display.
SXGA or below: less than 10 m
UXGA or higher: less than 5 m
- Use the optional cable shown below to input the DVI-D or RGB signal.
 - DVI-D: DVI-D/D S-LINK 5M/10M
 - RGB: BNCX5-DSUB15-L400 and CP24-01200/01210 (see section 2.7.2), or 3COX-2P-6C 5M/10M

Mounting

The video LAN converter can be mounted on the floor, or on a bulkhead.

Fasten the unit with four hex. bolts (M8x25), spring washer, flat washer, and hex. nut. The installation materials are supplied with the IF-7100.

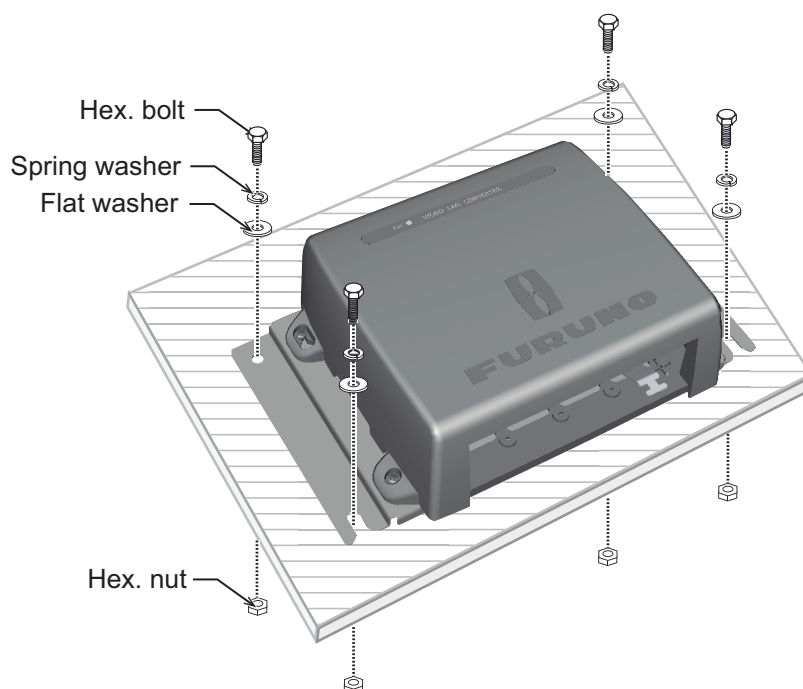

1.8 Sensor Adapter MC-3000S/3010A/3020D

Mounting considerations

Select a mounting location, keeping in mind the following points:

- Locate the unit away from heat sources.
- Select a location where the shock and vibration are minimal.
- Locate the unit away from places subject to water splash and rain.
- Make the maintenance space shown in the outline drawing for maintenance and checking purpose.
- A magnetic compass will be affected if the unit is placed too close to the magnetic compass. Observe the compass safe distances at the front of this manual to prevent interference to a magnetic compass.
- Select a mounting location considering the length of the cables to be connected to this unit.
- Select the mounting location considering the numbers of the sensor adapters connected.

A maximum of eight MC-3000S can be connected to the DCU through the HUB-100. The MC-3000S can connect a maximum of ten additional units in combination with MC-3010A and MC-3020D, using the MC1.5-W cables. However, note that five MC-3010A can be connected.

- Select the mounting location so that the length of cables among the sensor adapters (MC-3000S, 3010A, and 3020D) is less than 6 m. If the total length of the MC1.5-W is more than 6 m, the equipment may not work properly.

Mounting

1. Unfasten four binding screws to remove the cover from the sensor adapter.
2. Fasten four self-tapping screws ($\phi 4 \times 20$, supplied) to fix the sensor adapter.
3. Reattach the cover.

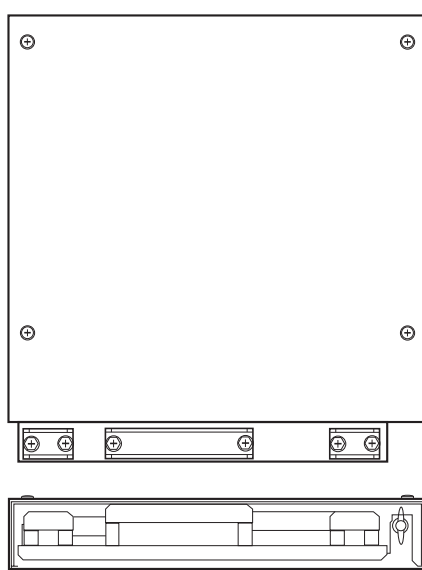

MC-3000S

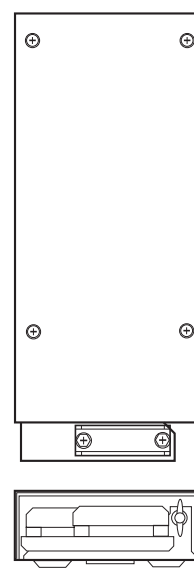

MC-3010A/3020D
(Option)

1.9 Intelligent HUB HUB-3000

Use the optional Intelligent Hub HUB-3000 to connect gateway network equipment. This network cannot be connected with the LAN network on board. Also, to connect with the non-FURUNO system or multiple Live Player V5 (PCs) use this unit.

Mounting considerations

Select a mounting location, keeping in mind the following points:

- Locate the unit away from heat sources.
- Select a location where the shock and vibration are minimal.
- Locate the unit away from places subject to water splash and rain.
- Make the maintenance space shown in the outline drawing for maintenance and checking purpose.
- A magnetic compass will be affected if the unit is placed too close to the magnetic compass. Observe the compass safe distances at the front of this manual to prevent interference to a magnetic compass.
- Select a mounting location considering the length of the cables to be connected to this unit.

Mounting

1. Use two binding screws (M3x6, supplied) to attach the cable clamp (supplied) to the bottom of the HUB-3000.

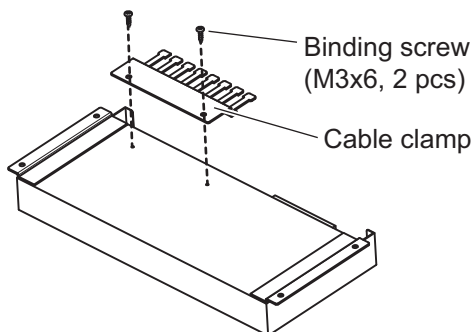

HUB-3000, bottom view

2. Fasten four self-tapping screws (4x20, supplied) to fix the unit.

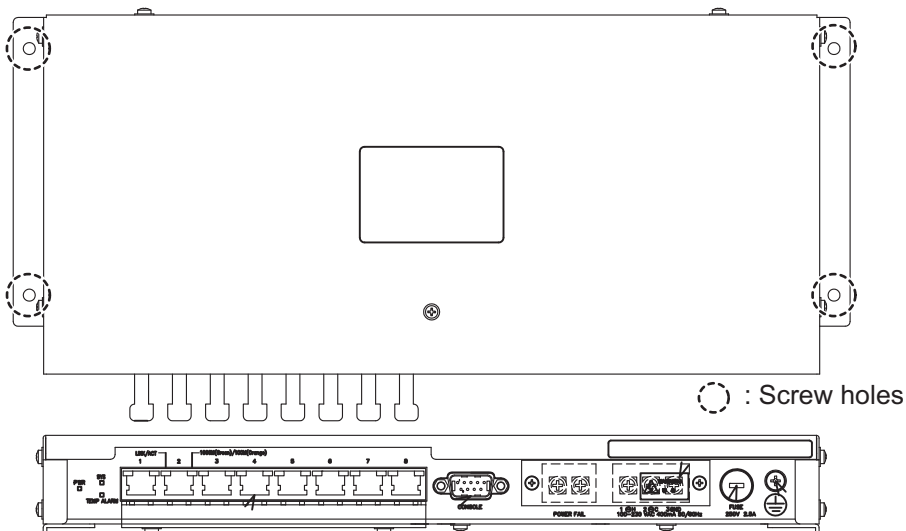

1.10 Power Supply Unit PSU-011

Mounting considerations

Select a mounting location, keeping in mind the following points:

- Locate the unit away from heat sources.
- Select a location where the shock and vibration are minimal.
- Locate the unit away from places subject to water splash and rain.
- Make the maintenance space shown in the outline drawing for maintenance and checking purpose.
- A magnetic compass will be affected if the unit is placed too close to the magnetic compass. Observe the compass safe distances at the front of this manual to prevent interference to a magnetic compass.
- Select a mounting location considering the length of the cables to be connected to this unit.

Mounting

The power supply unit PSU-011 is required for the Russian vessel. Fasten the unit to the mounting location with four self-tapping screws ($\phi 5 \times 20$, supplied).

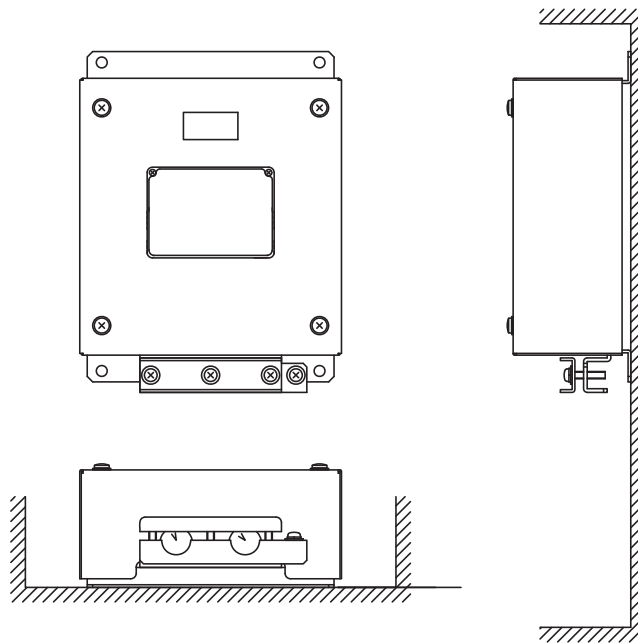

1.11 Switching HUB HUB-100 (Option)

Use the optional Switching HUB HUB-100 to connect sensor networks. This network cannot be connected to the LAN network on board. Note that a commercial PC cannot be connected in this network, other than for the maintenance.

For the mounting procedures, see the operator's manual for HUB-100 (Pub. No.OMC-35191).

Mounting considerations

Select a mounting location, keeping in mind the following points:

- Locate the unit away from heat sources.
- Select a location where the shock and vibration are minimal.
- Locate the unit away from places subject to water splash and rain.
- Make the maintenance space shown in the outline drawing for maintenance and checking purpose.
- A magnetic compass will be affected if the unit is placed too close to the magnetic compass. Observe the compass safe distances at the front of this manual to prevent interference to a magnetic compass.
- Select a mounting location considering the length of the cables to be connected to this unit.

1.12 Junction Box IF-8530 (Option)

The junction box interfaces the serial, analog and digital equipment with the DCU. Only one junction box can be connected to the DCU.

Signals and number of channels are shown below.

- Serial: IEC61162-1/2: 2 ch, IEC61162-1: 6ch
- Analog: 16 ch
- Digital: 64 ch

Mounting considerations

Select a mounting location, keeping in mind the following points:

- Locate the unit away from heat sources.
- Select a location where the shock and vibration are minimal.
- Locate the unit away from places subject to water splash and rain.
- Make the maintenance space shown in the outline drawing for maintenance and checking purpose.
- A magnetic compass will be affected if the unit is placed too close to the magnetic compass. Observe the compass safe distances at the front of this manual to prevent interference to a magnetic compass.
- Select a mounting location considering the length of the cables to be connected to the unit.
- For bulkhead mounting, be sure the mounting location is strong enough to support the weight of the unit (13 kg).

- The unit should be 4 m or more away from the VHF/MF/HF antennas.

Mounting

Install the junction box on a bulkhead or desktop with four M10 bolts or $\phi 10$ coach bolts (local supply).

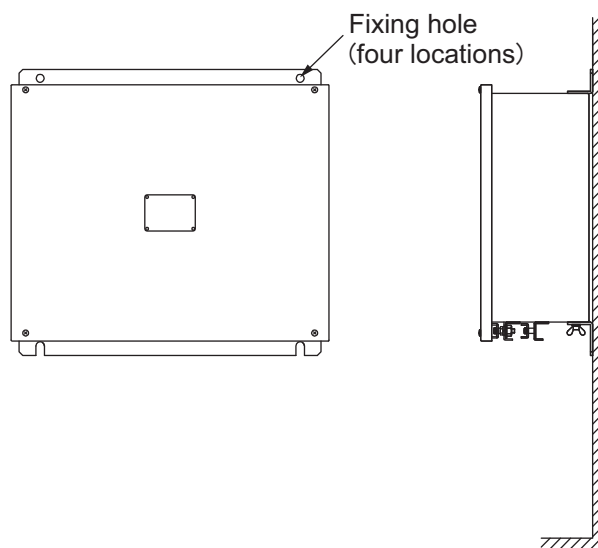

1.13 Junction Box IF-8540 (Option)

A maximum of six sensor adapters can be installed in the junction box (MC-3000S included). The units installed in the junction box change depending on the configuration purchased.

For the mounting and wiring procedures, see the Installation Instruction supplied with the IF-8540 (Pub. No.C42-01504).

1. MOUNTING

This page is intentionally left blank.

2. WIRING

The illustration on this page shows the general connection of the VR-7000/7000S. For detailed information, see the interconnection diagram. Many of the cables mentioned are JIS (Japanese Industrial Standards) cables. If not available locally, use the equivalent. See the cable guide in the Appendix for how to select equivalent cables.

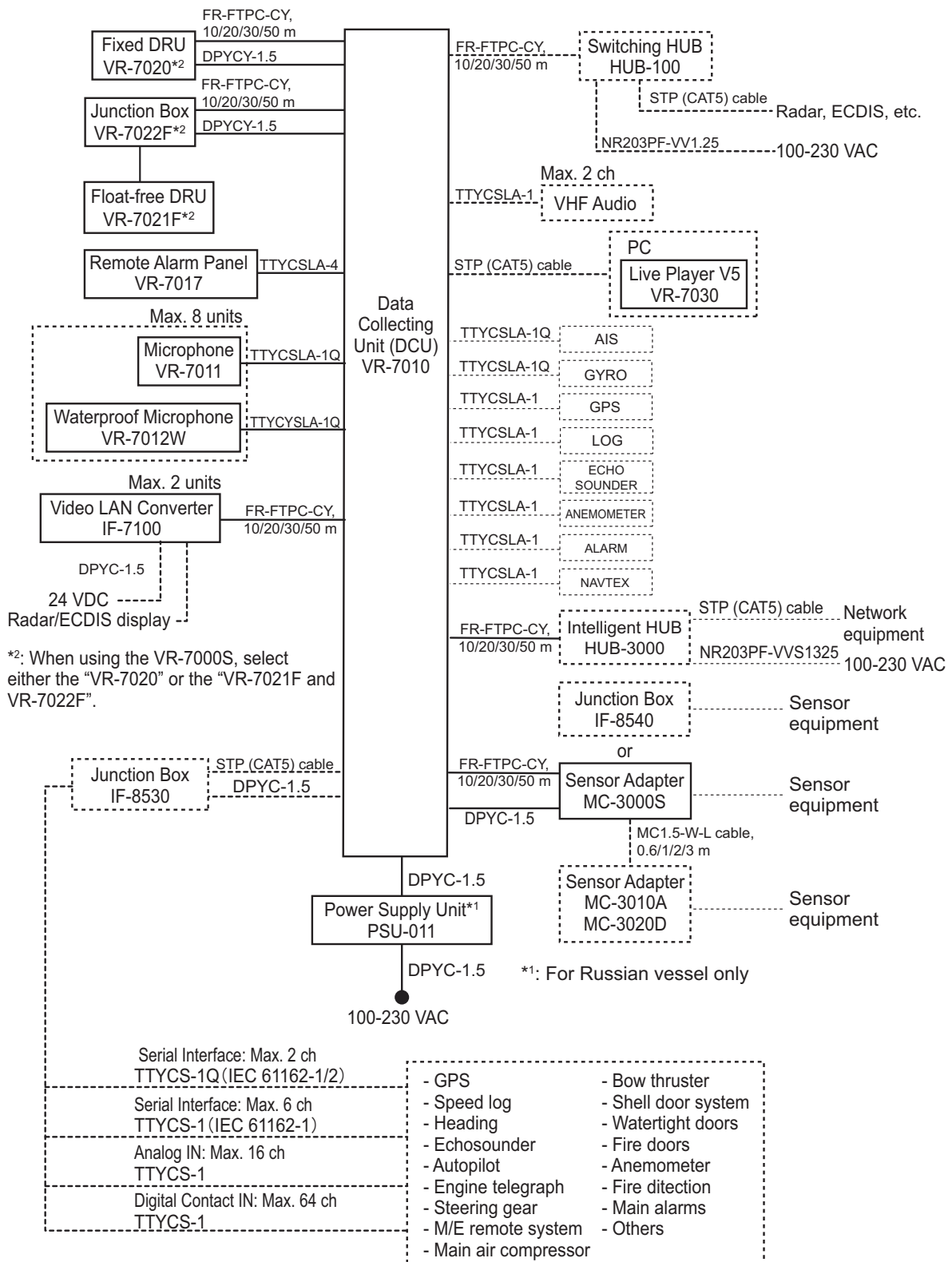

2.1 Data Collecting Unit VR-7010

Note: The DCU can record a maximum of five channels of video data, within the stipulated time. A maximum of seven channels of video data can be input, however six or more channels can not be recorded within the stipulated time. Note that the maximum record channel changes according to a resolution and video format. For details, see VR-7000/7000S operator's manual (OME-44850).

2.1.1 Location of connectors and terminals

To make connections, unfasten seven binding screws, then detach the cover from the DCU.

Note: Turn OFF the ship's mains before making connections.

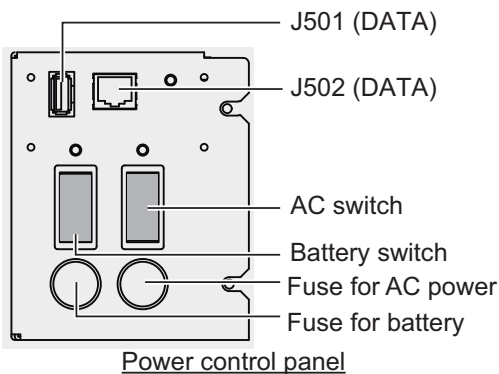
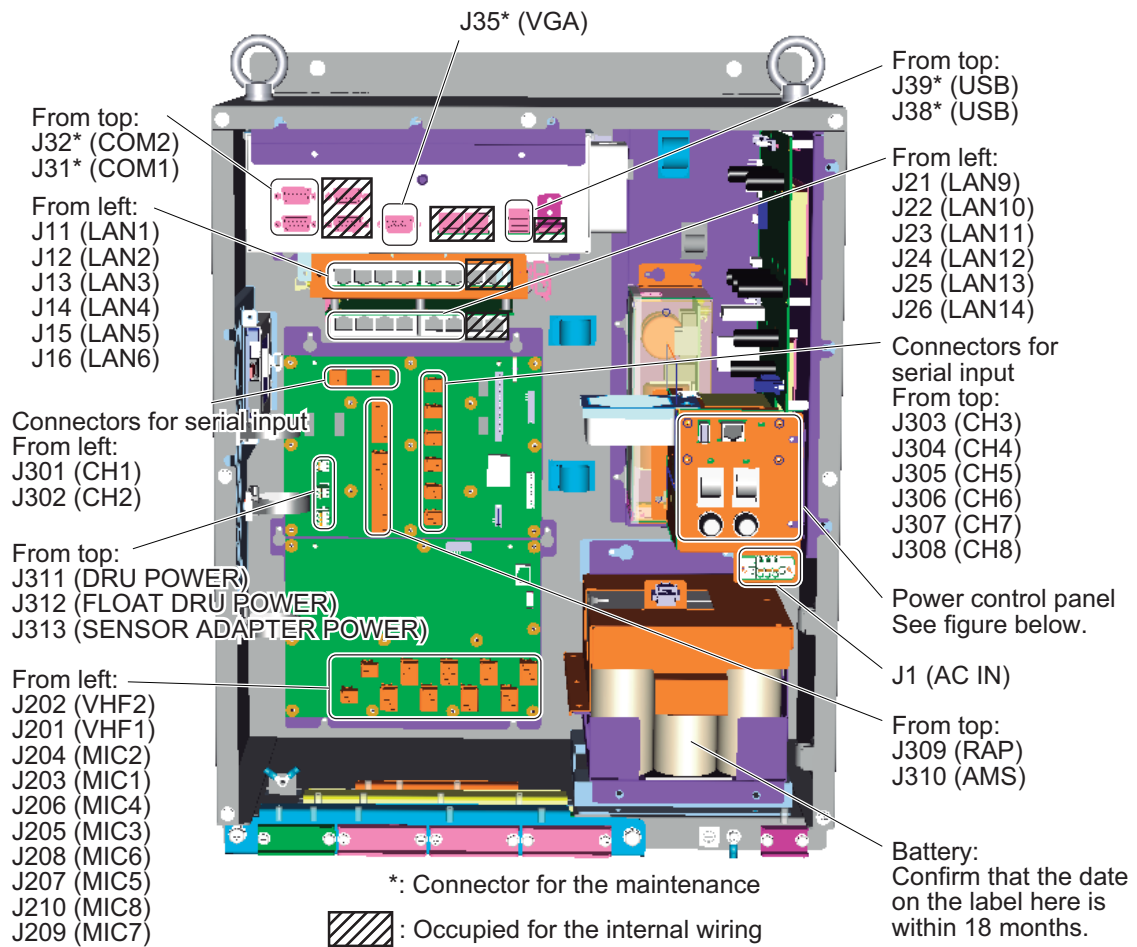

Power control panel

Data collecting unit (cover removed)

Cable clamp location

Fasten each cables connected to the DCU to the location shown below. Clamp the armor of the cable. When the armor of the cable is covered with vinyl (cable jacket), remove it so that the armor lies in the cable clamp.

Attach the cable band (supplied) to each cable to be connected to the DCU and record sensor name/equipment name on each cable band.

Note: If you mislay a cable, the cable clamp may not keep the cable securely.

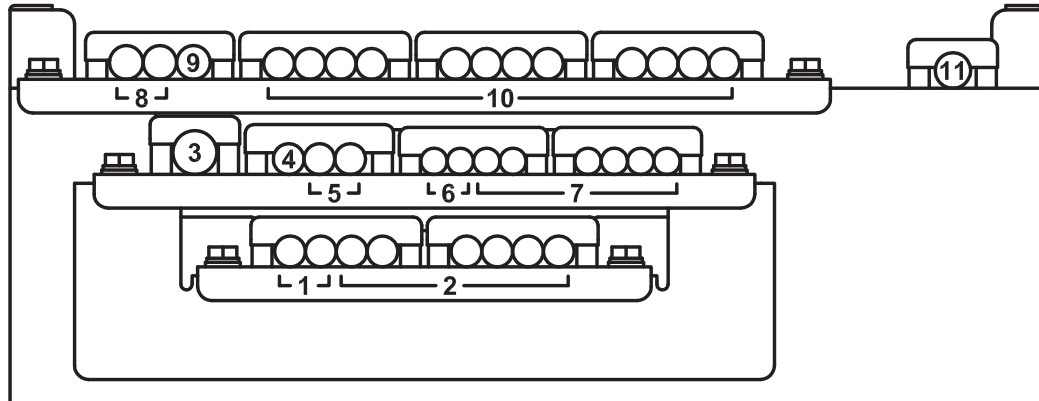

Clamp location No.	Cable	Connector No.	Signal/Unit to be connected
1	TTYCYSLA-1Q, TTYCSLA-1Q	J203-J210 (MIC1-MIC8)	Microphone, Waterproof microphone
2			
3	TTYCSLA-4	J309 (RAP)	Remote alarm panel
4	TTYCSLA-1Q	J310 (AMS)	AMS (Serial)
5	TTYCSLA-1Q	J301-J302 (CH1-CH2)	Serial input (IEC61162-1/2)
6	TTYCSLA-1	J201-J202 (VHF1-VHF2)	VHF audio, 2 channels
7	TTYCSLA-1	J303-J308 (CH3-CH8)	Serial input (IEC61162-1)
8	DPYCY-1.5*1	J311 (DRU POWER)	Output 24VDC for the fixed DRU
		J312 (FLOAT DRU POWER)	Output 24VDC for the float-free DRU
9	DPYCY-1.5*1	J313 (SENSOR ADAPTER POWER)	Output 24VDC for the sensor adapter or junction box (IF-8540)
10	FR-FTPC-CY, MPYC-12*2	J11-J16 (LAN1-LAN6)	Radar, ECDIS, sensor (IEC61162-450), sensor adapter, RMS, junction box (IF-8540)
		J21-J24 (LAN9-LAN12)	Float-free DRU, video LAN converter, junction box (IF-8530)
		J25-J25 (LAN13-LAN14)	Fixed DRU
11	DPYCY-1.5*1	J1 (AC IN)	100-230 VAC

*1: Attach the rod terminal to the signal cores. For details, see "ROD TERMINALS" on page AP-7.

*2: For the MPYC-12 cable, connect to the J310 (AMS) port for the connection of the contact signal. Clamp the MPYC-12 cable to the same position as the LAN cables (clamp location no. 10).

2. WIRING

Notice for the connection with the remote alarm panel

When connecting the DCU to the remote alarm panel (RAP), do as follows to prevent the malfunction due to the difference of ground voltages between the DCU and RAP.

1. Connect the ground terminal of the DCU and remote alarm panel to the ship's ground.
2. Connect the serial cable to either J309 port of the DCU or J101 port of the remote alarm panel.
3. For the port not connected at step 2, insert the signal core to **# 5 pin (GND) only**, then connect the connector.
4. Disconnect the connector connected at step 3, then insert other signal cores and reconnect the connector.

Crimp-on lug for the drain wire

Two crimp-on lugs are preattached in the DCU (see the figure below). Attach the crimp-on lug to the drain wire of the cable for the AMS (serial) and remote alarm panel, then connect the lug to its original location.

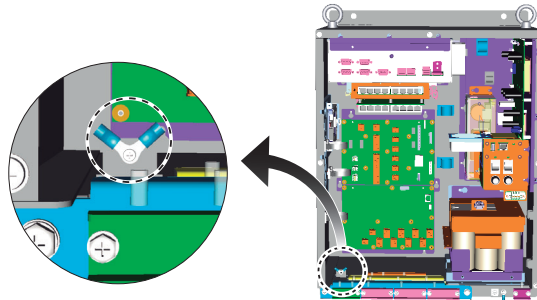

2.1.2 Power supply

Connect the AC power 100-230 VAC to J1 of the DCU through the emergency switch board (ESB). For the connection, use the DPYC-1.5 cable. The DCU is compatible with 100-230 VAC input (universal power supply), so it is not necessary to change the tap setting on the switchboard.

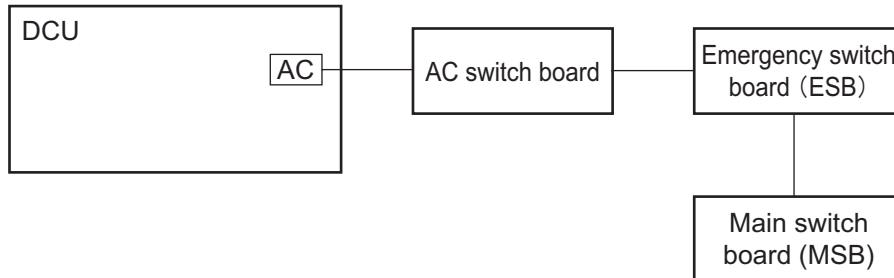

2.1.3 Ground connection

To ground the DCU, use the crimp-on lug preattached to the DCU (see figure below). Attach the crimp-on lug to the ground wire (1V-2sq.), then connect the lug as shown below.

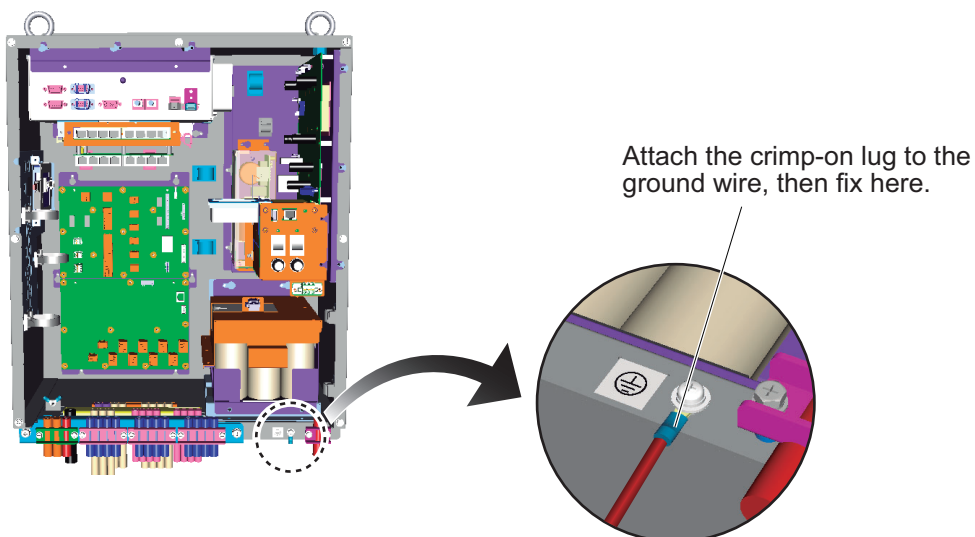

2.1.4 Changing internal LAN connection (for video signal input with IEC61162-450 format)

The J502 port (DATA) is connected to the J17 port internally in default. When you input the radar/ECDIS video signal with the IEC61162-450 (LAN) format, disconnect the LAN cable from the J17 port and connect it to the J26 port.

Note: To record chart information, video signal input from the ECDIS is required.

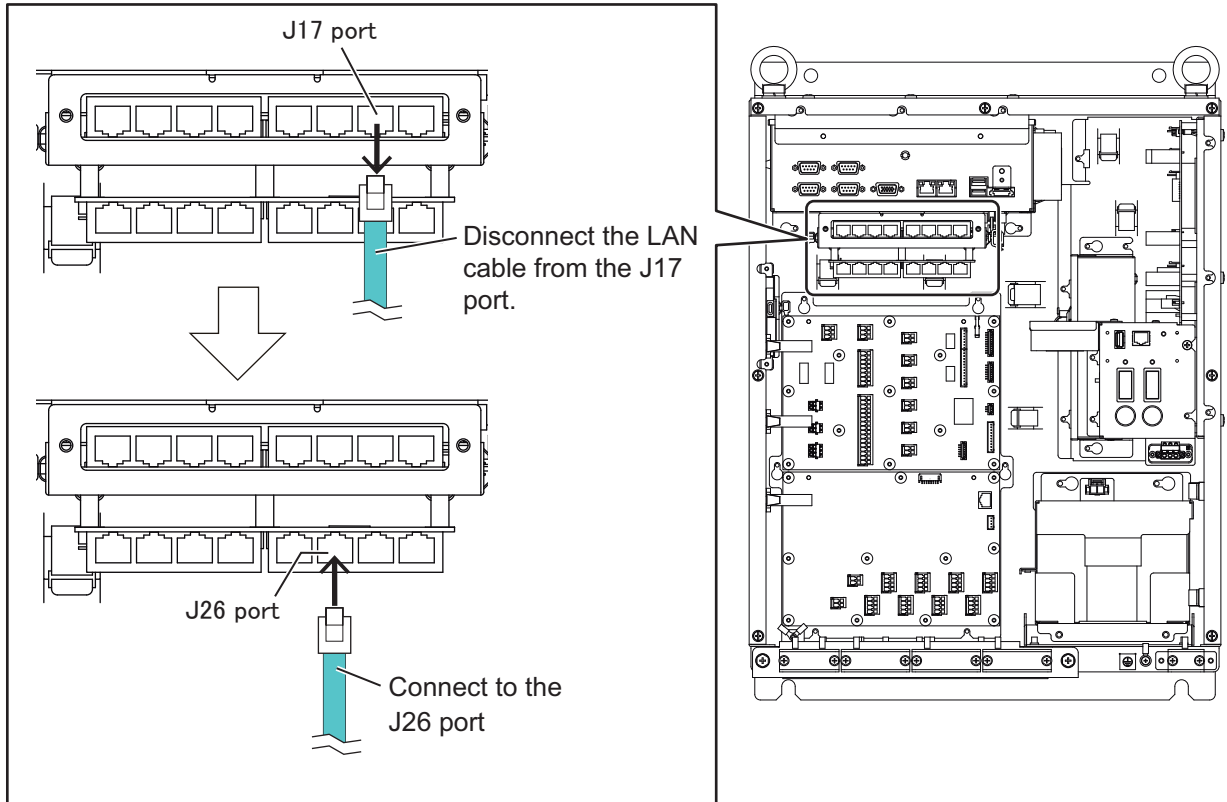

According to the access point (J17 or J26), the IP address for the VDR and PC changes.

Access point for J502	IP address for VDR	IP address for PC
J17 (Default)	172.31.16.200	172.31.16.201 or 172.31.16.202
J26	10.0.0.100	10.0.0.101 or 10.0.0.102

2.1.5 Alarm Monitoring System

Connect the AMS (Alarm Monitoring System) to J310 of the DCU. The connector J310 can output/input signals shown below.

Output

- System failure
- Power failure
- Local ACK

Input

- Remote ACK
- Buzzer stop

Connector J310

Pin #	Signal name	Input/Output	Cable	
1	RD_H_AMS	Input	TTYCSLA-4	
2	RD_C_AMS			
3	TD_A_AMS	Output		
4	TD_B_AMS			
5	GND	-	No connection	
6	SYS_FAIL+	Output	MPYC-12	
7	SYS_FAIL-			
8	POWER_FAIL+	Output		
9	POWER_FAIL-			
10	LOCAL_ACK+	Output		
11	LOCAL_ACK-			
12	REMOTE_ACK+	Input		
13	REMOTE_ACK-			
14	BUZZER_STOP+	Input		
15	BUZZER_STOP-			
16	NC	-		No connection

System failure (output)

The VR-7000/7000S notifies the AMS that an alert has been generated. The system failure signal is output as normally closed (NC).

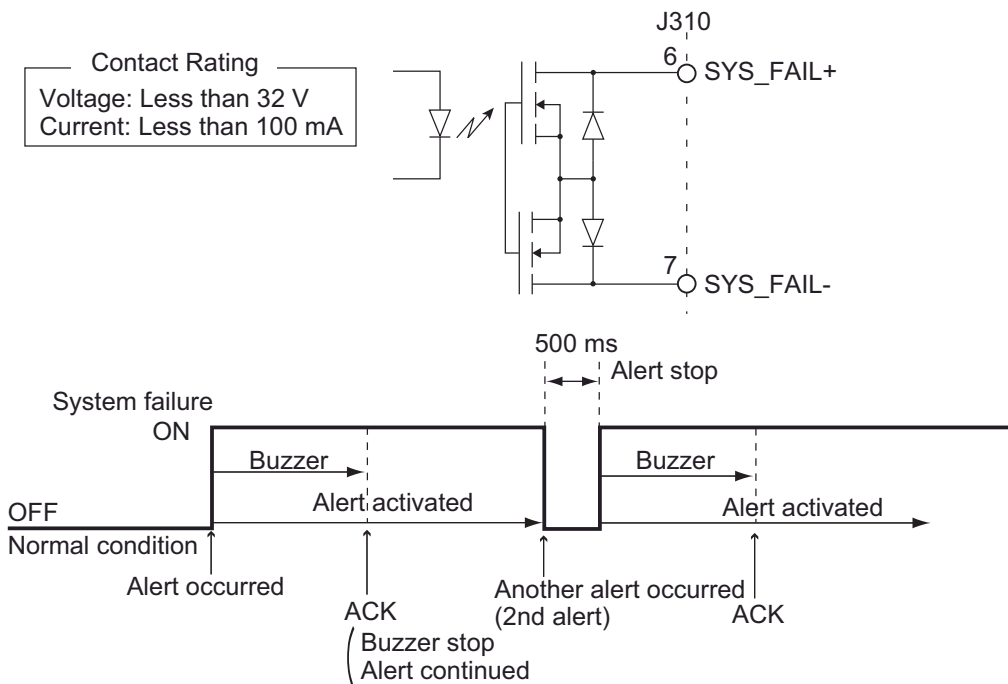

Power failure (output)

The VR-7000/7000S notifies the AMS of power failure. The power failure signal is output as normally close (NC).

- Supplied by AC power: Close
- Power off or supplied by the battery: Open

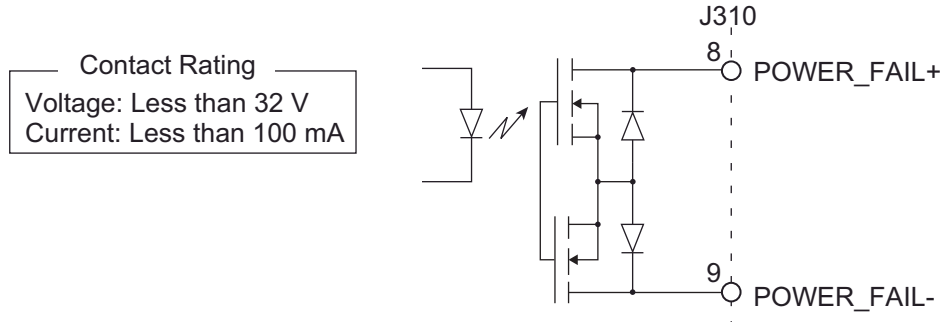

Local ACK (output)

The VR-7000/7000S notifies the AMS that it has acknowledged an alarm. The alarm acknowledge signal is output as normally open (NO).

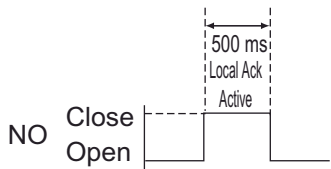
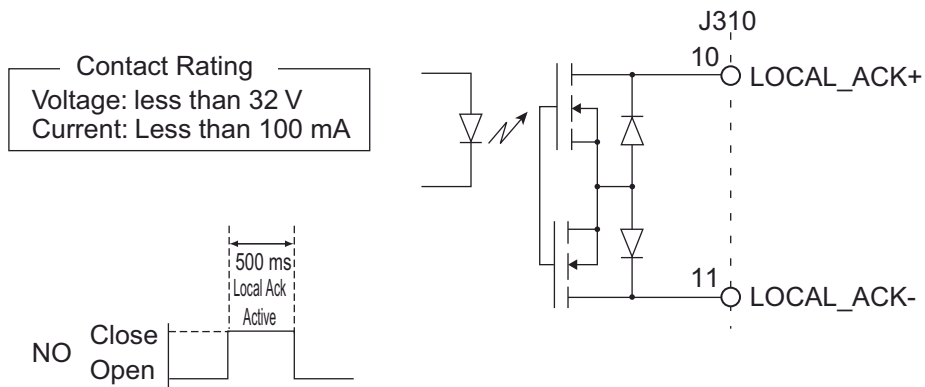

Active interval of Local ACK signal is 500 ±5 msec.

Local ACK signal

Remote ACK (input)

The AMS notifies the VR-7000/7000S that it has acknowledged an alarm. The remote ACK signal is input as normally open (NO).

Note: Input the contact signal. Voltage can not be input.

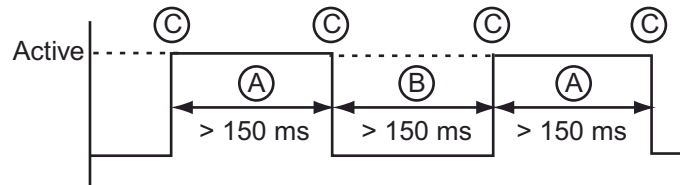
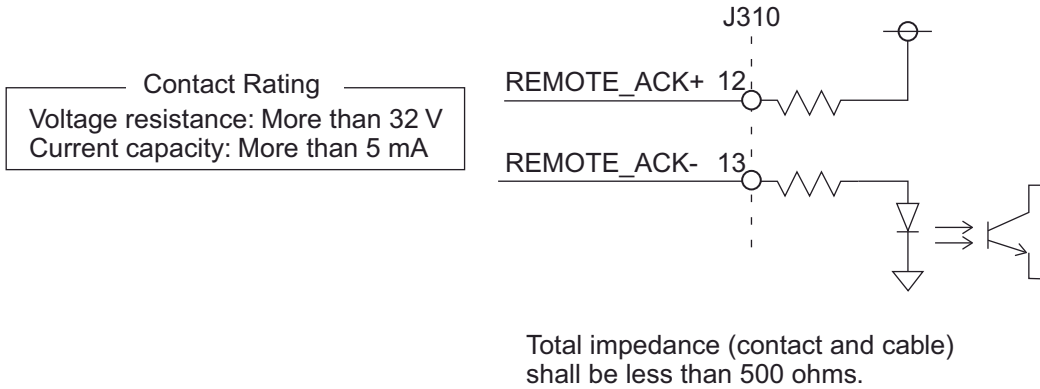

Active interval (A) and (B) of Remote ACK signal shall be more than 150 msec.
Chattering may be present at interval (C).

Remote ACK signal

Buzzer stop (input)

The AMS notifies the VR-7000/7000S that it has acknowledged the buzzer stop. The buzzer stop signal is input as normally open (NO).

Note: Input the contact signal. Voltage can not be input.

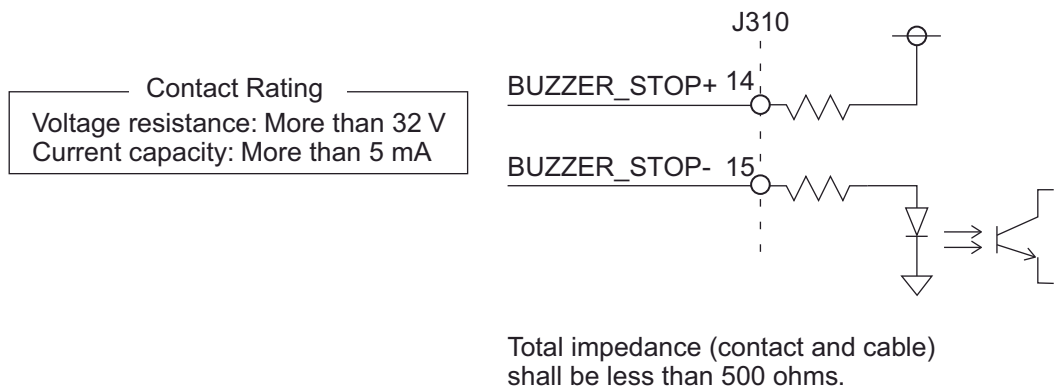

2.2 Data Recording Unit

2.2.1 Fixed Data Recording Unit VR-7020

A good grounding bond is required between the fixed DRU base plate and ship hull. Be sure that the external tooth lock washers are clamped between the bare metal of the fixed DRU base plate and the bare hull by the mounting bolts. See the figure on page 1-4.

Power and Ethernet Wiring Diagram

Connect the power and Ethernet signal to the terminal board. Supply the power source from the DCU (J311).

Note 1: Ensure that electrical power is de-energized prior to connecting the fixed DRU electrical power supply.

Note 2: Connect the Ethernet cable (FR-FTPC-CY) before connecting the power cable.

1. Pass the cables through the terminal board cover (supplied).
2. Use the rod terminal (supplied) to connect the signal cores of the cables to the terminal board.
 DPYCY-1.5 cable: Use the rod terminal AI 1.5-6 BK.
 FR-FTPC-CY cable: Use the rod terminal AI 0.14-8 GY.

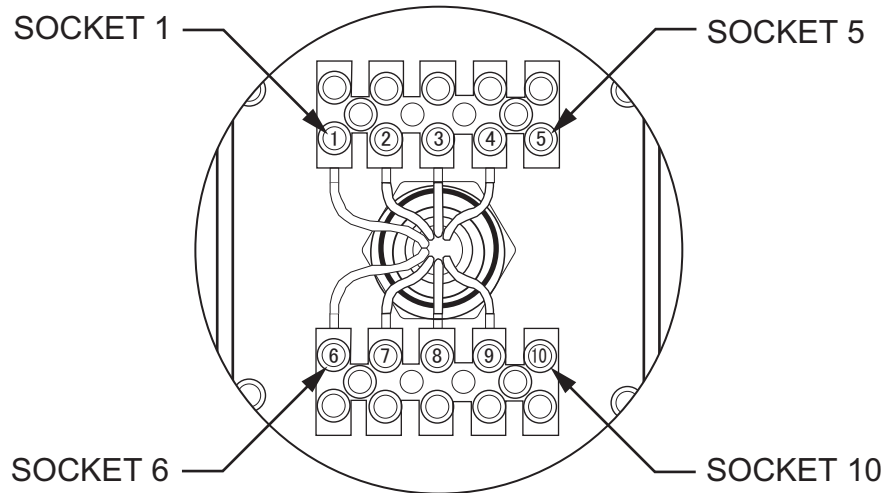

Power and Ethernet Terminal Block Front View

Socket number	Signal	Cable
1	24 V	DPYCY-1.5
2	24 V	No connection
3	0 V	DPYCY-1.5
4	0 V	No connection
5	N/C	No connection
6	TD_P	FR-FTPC-CY
7	TD_N	
8	RD_P	
9	RD_N	
10	N/C	No connection

Cable fabrication

- DPYCY-1.5 cable

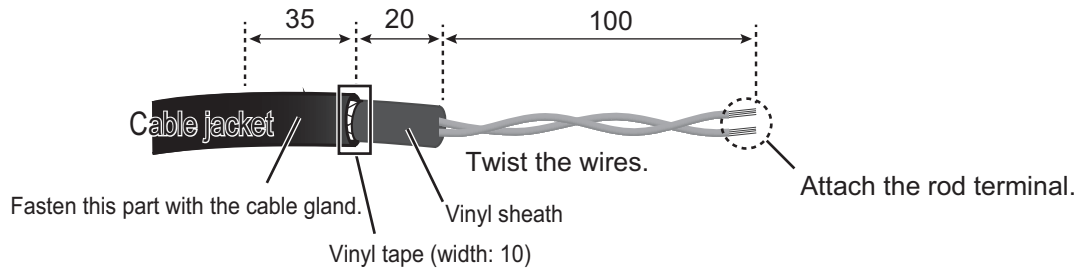

- FR-FTPC-CY cable

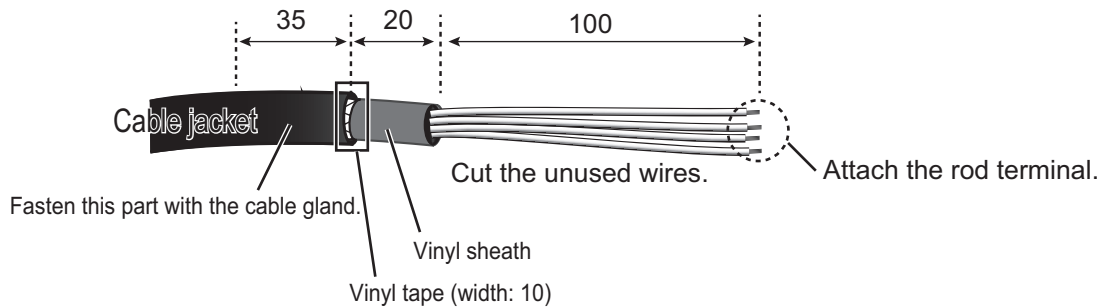
**Notes for wiring**

- Insert the rod terminals to the terminal board securely and fasten the terminal board screws to keep the wires from touching the terminal board cover.
- When it is hard to attach the rod terminal to the cores of the DPYCY-1.5 cable, cut out the wire jacket. Be careful not to damage the cores when cutting the wire jacket



Cut the wire jacket.

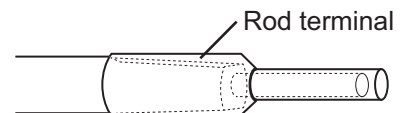

Attach the rod terminal to the core.

- When it is hard to insert the rod terminals attached to the FR-FTPC-CY cable to the terminal board, cut the rod terminal about 2 mm.

2. WIRING

- Attach the terminal board cover to the unit with six screws (supplied).

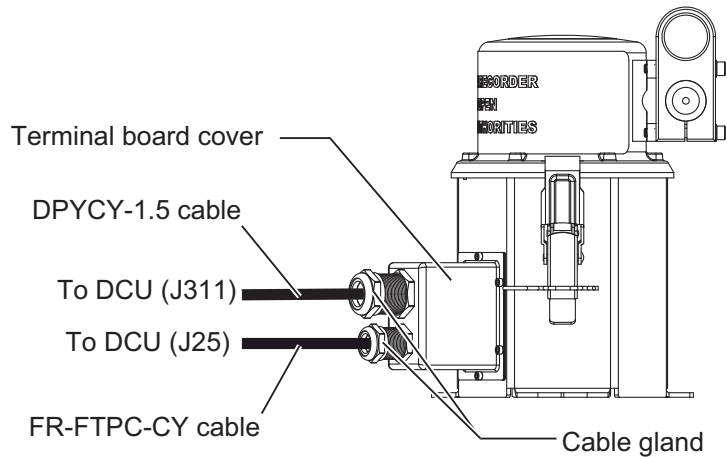

- Fasten two cable glands.
Tightening torque:
 - Upper cable gland: 6.67 N•m
 - Lower cable gland: 5 N•m
- To prevent water from entering into the unit, apply the supplied silicone rubber (S-8400W) to the cable entrances and contact area between the terminal board cover and unit.

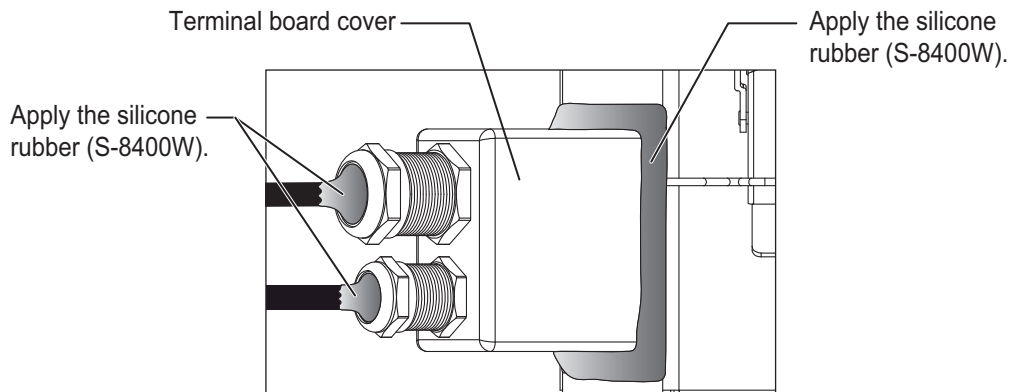

2.2.2 Float-free Data Recording Unit VR-7021F

To connect the float-free data recording unit VR-7021F to the DCU, use the junction box VR-7022F. For details, see section 2.3.

LED indication of the docking module

After wiring the float-free DRU, check the LED on the docking module to confirm that the float-free DRU works properly. See the following table for the LED indication meanings.

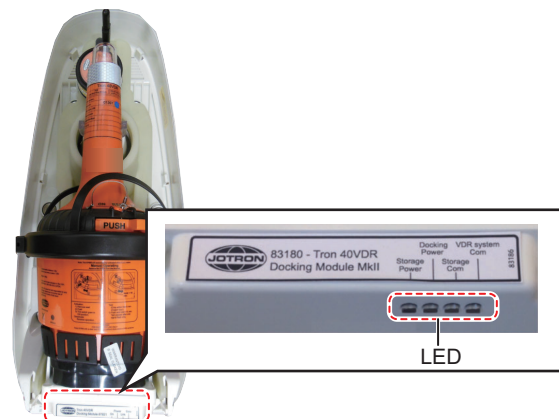

LED	Storage Power	Docking Power	Storage Com	VDR system Com
ON	Power is supplied to the storage module.	Power is supplied to the docking module.	The storage module is connected to the docking module, but communication is not established.	The DCU is connected to the docking module, but communication is not established.
OFF	Power is not supplied to the storage module.	Power is not supplied to the docking module.	The storage module is not connected to the docking module.	The DCU is not connected to the docking module.
Flash	The watchdog is activated.	The watchdog is activated.	The storage module is connected to the docking module and communication is established correctly.	The DCU is connected to the docking module and communication is established correctly.

2.3 Junction Box VR-7022F

To connect the float-free data recording unit VR-7021F to the DCU, use the junction box VR-7022F.

For configurations that use the VR-7020, the installation procedures outlined in this section and section 1.3 are not required.

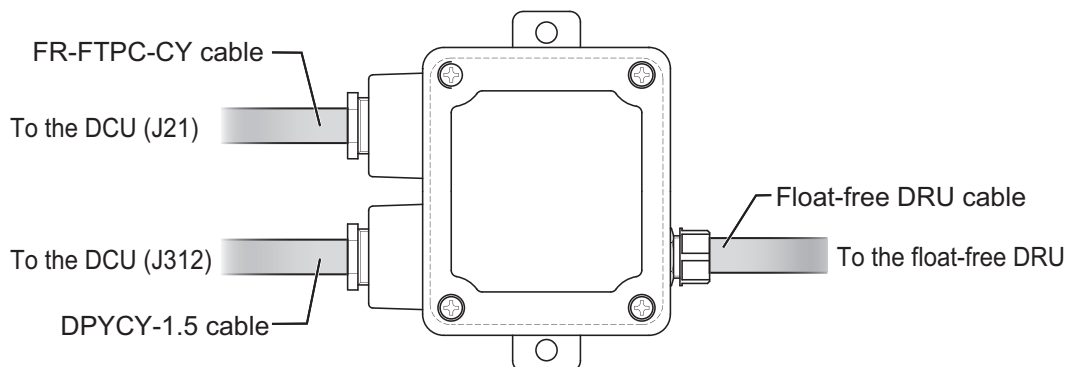

1. Remove four screws to remove the cover from the junction box.
2. Unfasten three cable glands, then pass each cable through the cable entrance.
3. Fabricate the cables.
 - DPYCY-1.5 cable

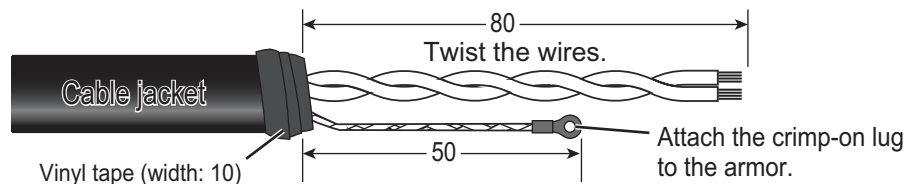

2. WIRING

- FR-FTPC-CY cable

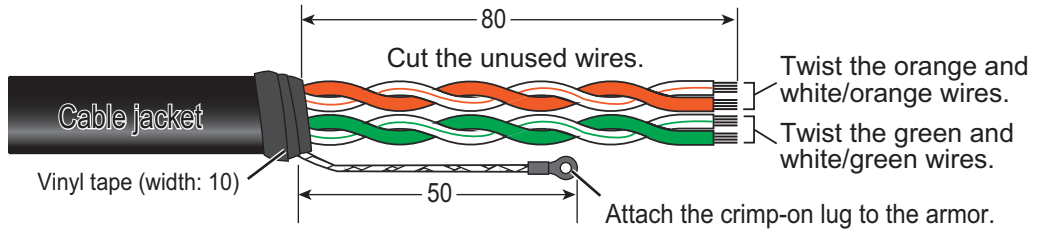

- Float-free DRU cable

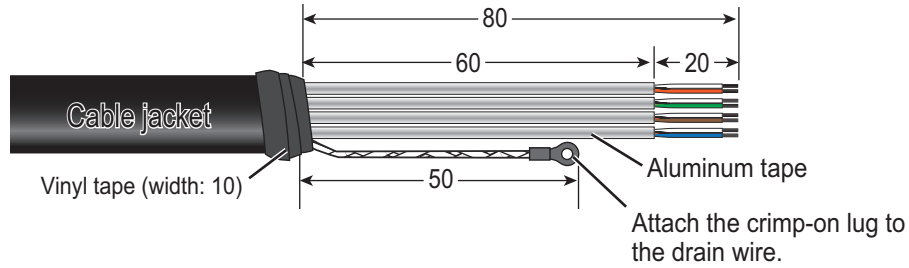

4. Connect the wires to the terminal board of the junction box.

Note: The float-free DRU cable may be different, depending on the time of manufacture. Therefore, wire colors that connect to the #3 and #4 pins in the VR-7022F depend on the cable specifications.

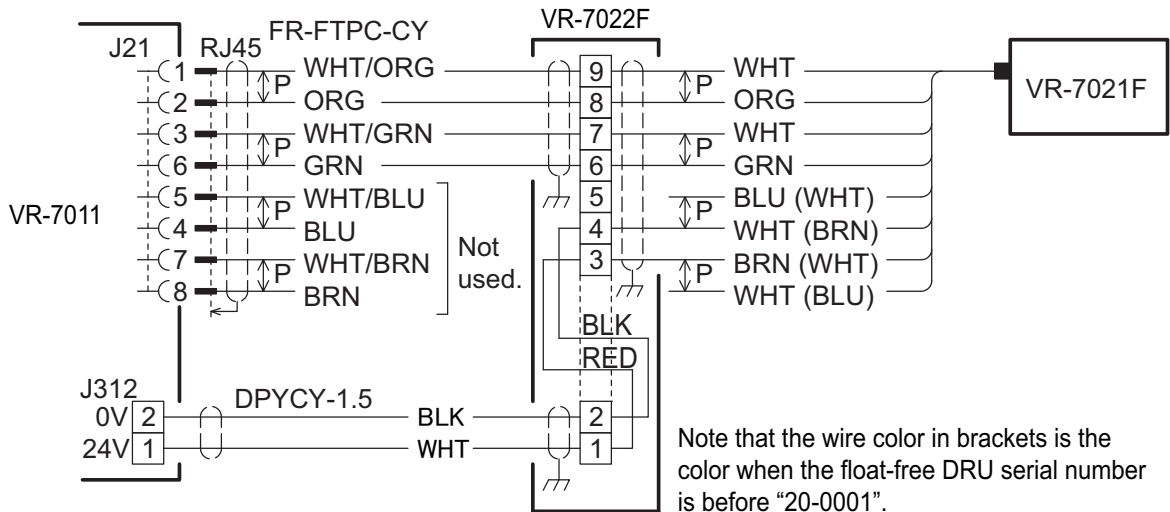

5. Fasten the cable glands to fix the cable.

The cables must project 10 mm inside of the junction box.

Note: Fasten the cable glands by hand. Do not use a wrench, to prevent damage to the gland.

Secure the shield (armor) of the FR-FTPC-CY cable to the junction box chassis.

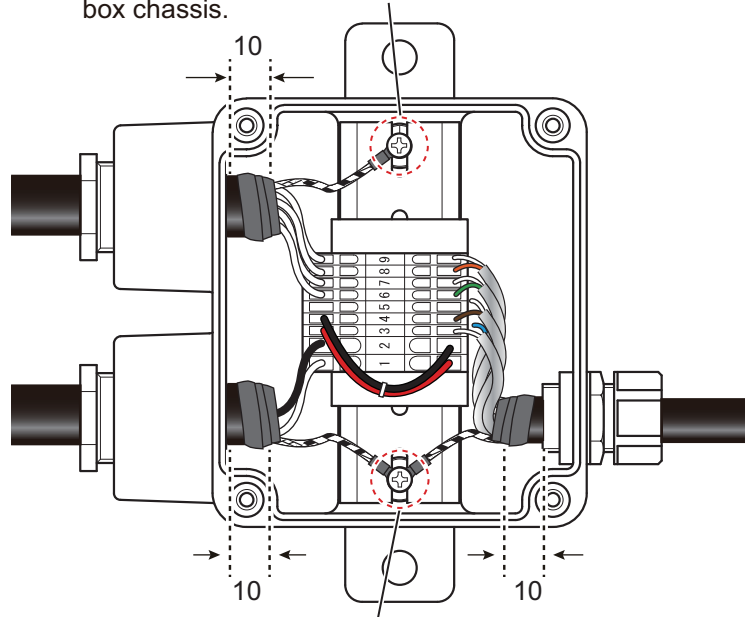

Secure the shield (drain wire) of the float-free DRU and the shield (armor) of the DPYCY-1.5 cable to the junction box chassis.

6. Reattach the cover to the junction box.
7. To prevent water from entering into the unit, apply the supplied silicone sealant (KE-347-W-100) to cable entrances (three locations).

2.4 Remote Alarm Panel VR-7017

Connect wiring to the terminal board of the unit, referring to the interconnection diagram at the back of this manual. See appendix 2 for how to fabricate the cable. After wiring the cable, fix the cable with the cable clamp.

Remote alarm panel (back cover removed)

After fabricating the cable, connect it the connector J101.

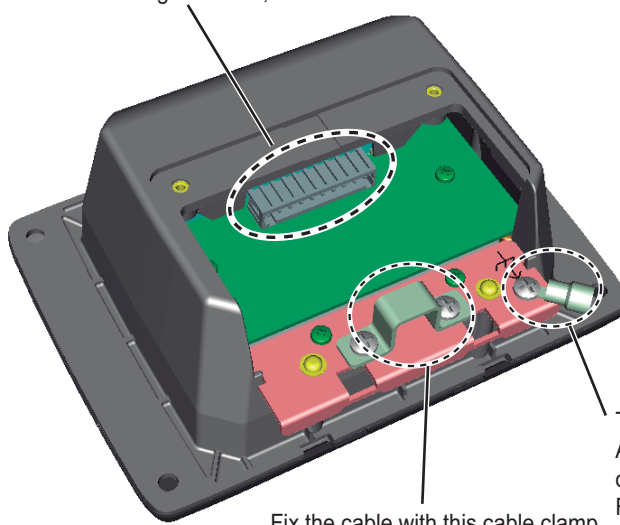

Connector J101

Pin No.	Signal	In/Out
1	TD_A	Out
2	TD_B	Out
3	RD_H	In
4	RD_C	In
5	GND	-
6	NET_S (24V)	In
7	NET_C (0V)	-
8*	NC	-
9*	NET_H	-
10*	NET_L	-

*: No connection

The crimp-on lug is preattached here. Attach the crimp-on lug to the drain wire of the cable connected with the DCU. Fix the ground and drain wire (crimp-on lug) here.

Fix the cable with this cable clamp.

Note: When you connect between the DCU and remote alarm panel, see "Notice for the connection with the remote alarm panel" on page 2-4.

2.5 Microphone VR-7011

Connect wiring to the terminal board of the unit, referring to the interconnection diagram at the back of this manual. See appendix 2 for how to fabricate the cable.

Microphone (back cover removed)

After fabricating the cable, connect it to the connector J1.

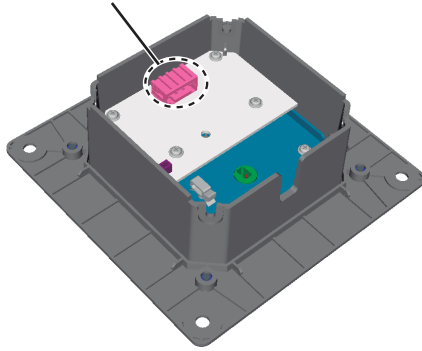

Connector J1

Pin No.	Signal	In/Out
1	12 VDC	In
2	GND	-
3	MIC_AUDIO	Out
4	MICTEST	In

After wiring the cable, reattach the back cover to the unit. Then fix the cable to the cable clamp with the cable tie (supplied).

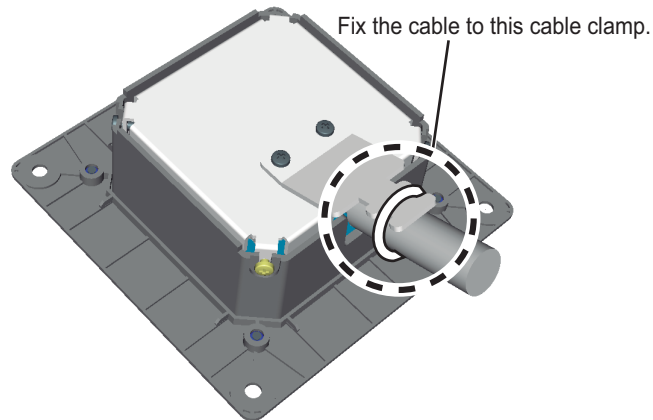

2.6 Waterproof Microphone VR-7012W

Connect wiring to the terminal board of the unit, referring to the interconnection diagram at the back of this manual. See section 1.6 for how to fabricate the cable.

Front panel of the waterproof microphone (rear side)

After fabricating the cable, connect it to the connector J1.

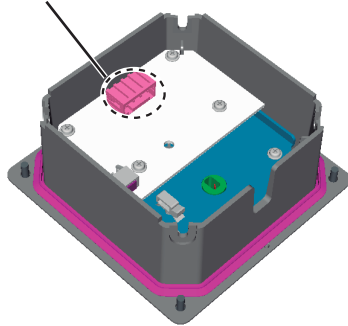

Connector J1

Pin No.	Signal	In/Out
1	12 VDC	In
2	GND	-
3	MIC_AUDIO	Out
4	MICTEST	In

After wiring the cable, reattach the front panel to the waterproof cover. Then fasten the super gland or SC lock to fix the cable.

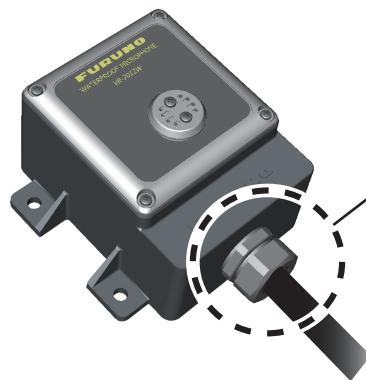

Fasten the cable gland or cable lock.

2.7 Video LAN Converter IF-7100

The video LAN converter converts the radar/ECDIS video signal (DVI-D or RGB) to a LAN signal. Use the optional cable shown below to input the DVI-D or RGB signal.

- DVI-D: DVI-D/D S-LINK 5M/10M
- RGB: BNCX5-DSUB15-L400 and CP24-01200/01210 (see section 2.7.2), or 3COX-2P-6C 5M/10M

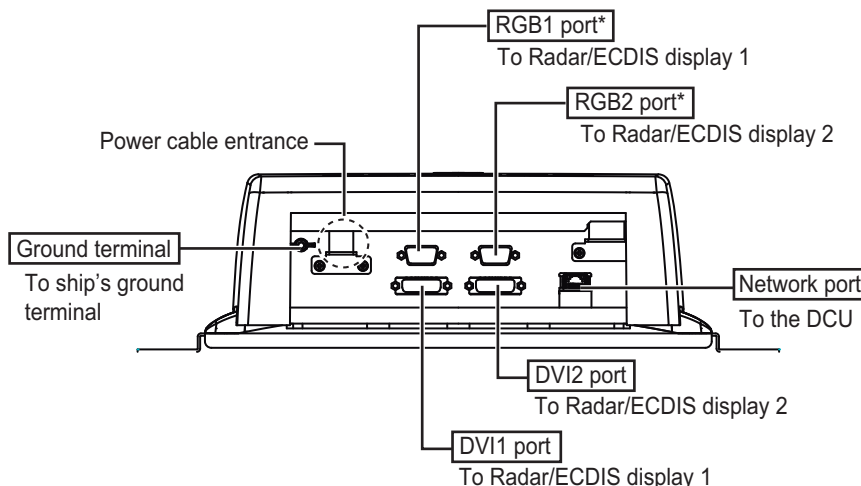

The video LAN converter has two input channels for DVI-D and two input channels for RGB*. The combinations of input channels shown below are available. Set the input channels for the video LAN converter, using the Maintenance Viewer program. For how to set, see the operator's manual of the Maintenance Viewer (OME-44852).

- DVI1 and DVI2
- RGB1* and DVI2
- DVI1 and RGB2*
- RGB1* and RGB2*

*: The RGB1 and RGB2 ports are available when the serial number (SER.NO.) of the video LAN converter is "200001" or after. If you need to input the RGB signal to the unit whose serial number (SER.NO.) is before "200001", use the RGB-DVI converter (maker: IMAGENECS, model: RS-1530A) to convert to the DVI-D signal.

Note 1: Do not connect/disconnect the DVI-D or RGB connectors while the turning the power on.

Note 2: Turn on or off the IF-7100 and connected equipment (radar or ECDIS processor unit) in the order shown below.

- Turning the power on: Turn on the IF-7100 before the connected equipment.
- Turning the power off: Turn off the connected equipment before the IF-7100.

Note 3: The IF-7100 does not have a power switch. Turn off the IF-7100 from the main switchboard.

Note 4: The IF-7100 can detect and adjust the DVI-D signal automatically. However, the RGB signal must be manually adjusted, using the Maintenance Viewer program. For how to adjust, see the operator's manual of the Maintenance Viewer (OME-44852).

Note 5: When you use the IF-7100 that is compatible with RGB signal input, update the programs shown below to version 1.04 or after.

- VDR System Program
- Live Player V5
- Maintenance Viewer

2.7.1 Video signal (DVI-D/RGB) available with IF-7100

The IF-7100 is compatible with separate sync signals shown below.

- Video signal level: Compliant with the VESA standard.
- Horizontal sync signal: Max.91.146 kHz, positive or negative
- Vertical sync signal: Max. 85 Hz

The table below shows receivable resolution for the IF-7100.

Resolution	DVI-D	RGB
VGA (640×480)	OK	OK
SVGA (800×600)	OK	OK
XGA (1024×768)	OK	OK
Resolution for FAR-28×7 series (1360×1024)	OK	OK
Resolution for FAR-2××8 series, WXGA+*1 (1440×900)	ON	NG
SXGA (1280×1024)	OK	OK
WSXGA+ (1680×1050)	OK	NG
UXGA (1600×1200)	OK	OK
Full HD*2 *3(1920×1080)	OK	NG
WUXGA*3 (1920×1200)	OK	NG
Resolution for FAR-28×5 series (1066×800)	NG	OK

*1. To receive WXGA+ video signal, the IF-7100 FPGA program version should be "01.03" or later and serial number (SER.NO.) should be "200991" or later.

*2. Compliant with CEA standard,

*3. For the maximum channel number that can be recorded, see "Recordable resolution and maximum channel number" below.

Recordable resolution and maximum channel number

When the video signal is input through the IF-7100, the resolution and maximum channel number that can be recorded are shown in the table below.

No. of pcs	Resolution/Max. channel number
1 SSD (512 GB)	UXGA 2 ch*1 + Full HD 1 ch*1
2 SSDs (1 TB)	UXGA 2 ch*1 + Full HD 1 ch*1 + WUXGA 1 ch*2

*1: Recorded to the long term device (SSD), fixed DRU and float-free DRU.

*2: Recorded to the long term device (SSD) only.

2.7.2 Fabrication of the coaxial cable

When you connect the IF-7100 with a radar or ECDIS using the coaxial cable, prepare the optional cable shown below.

- BNCX5-DSUB15-L400: D-SUB-BNC connector cable
- CP24-01200/01210: Coaxial cable (six core, unfabricated) with BNC connectors

Fabricate the coaxial cable as follows:

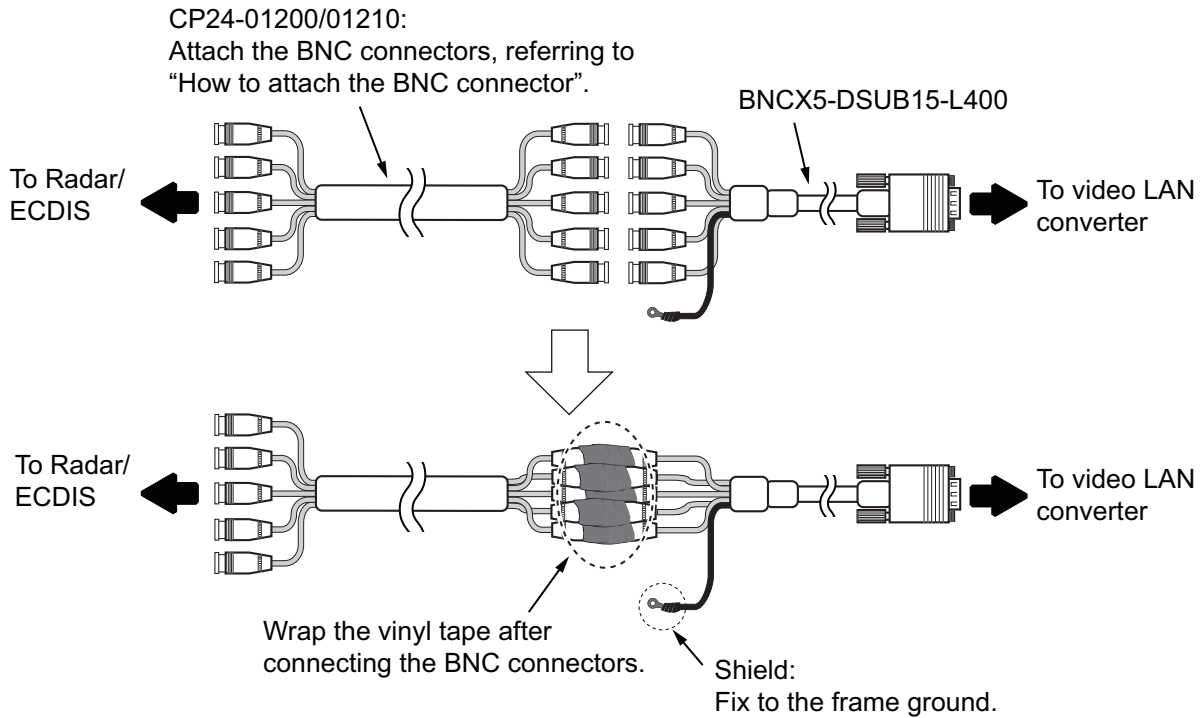

How to attach the BNC connector

1. Pass the clamping nut, washer, and gasket onto the cable.
2. Remove the vinyl sheath by 7 mm.

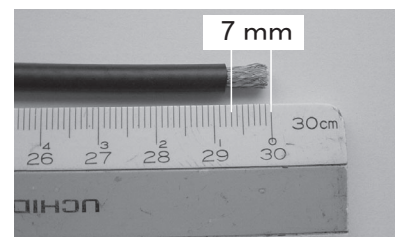
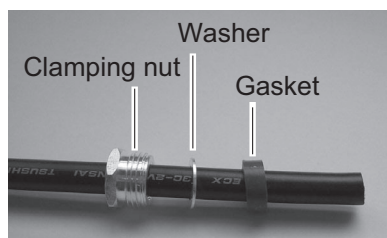

3. Remove the shield and insulator by 3 mm.
4. Pass the clamp onto the cable and fold back the shield on to the clamp.

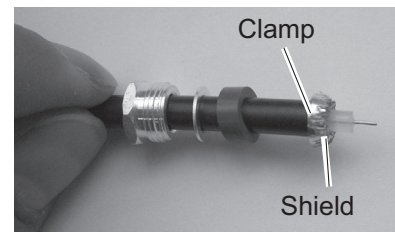
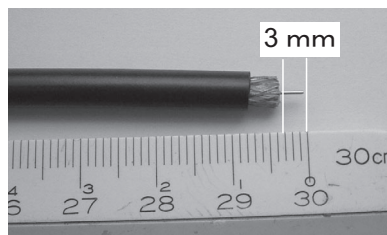

5. Insert the center pin to the core and solder.
6. Screw the shell into the cable.

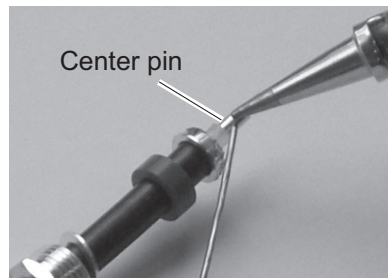

7. Completed.



2.7.3 Connections

1. Remove the outside cover of the video LAN converter; hold the right and left sides of the cover and pull the cover outward.
2. Remove eight binding screws (M3x6) to detach the chassis cover.

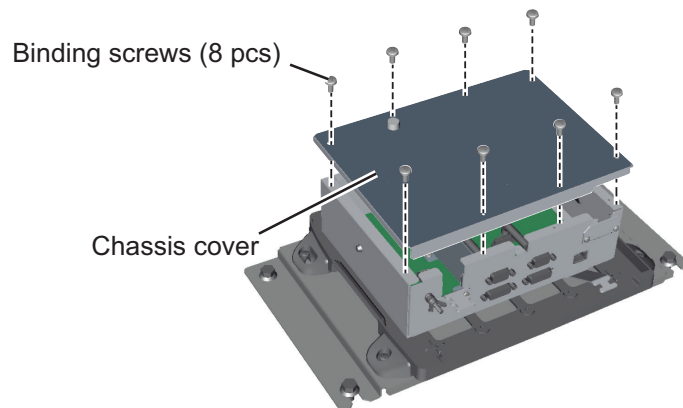

3. Fabricate the power cable.
Remove the armor and vinyl sheath by 226 mm, then expose the signal cores by 6 mm. Wrap vinyl tape around the edge of the armor.

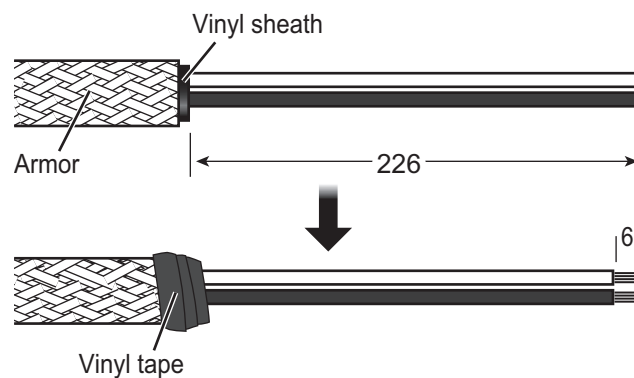

2. WIRING

4. Fix the armor of the power cable to the cable clamp, using the supplied cable tie.
5. Attach the supplied rod terminal (type: A1.5-10) to the signal cores for connection to the J1 port.
6. Connect the cores to the connector that is pre-inserted at the J1 port.
7. Fold the excess cable (inside the unit), then fix the excess cable at the cable saddle indicated in the figure below.

Note: The cable length between the cable saddle and J1 port should be as short as possible. Also, route the cables so that they do not make contact with the armor.

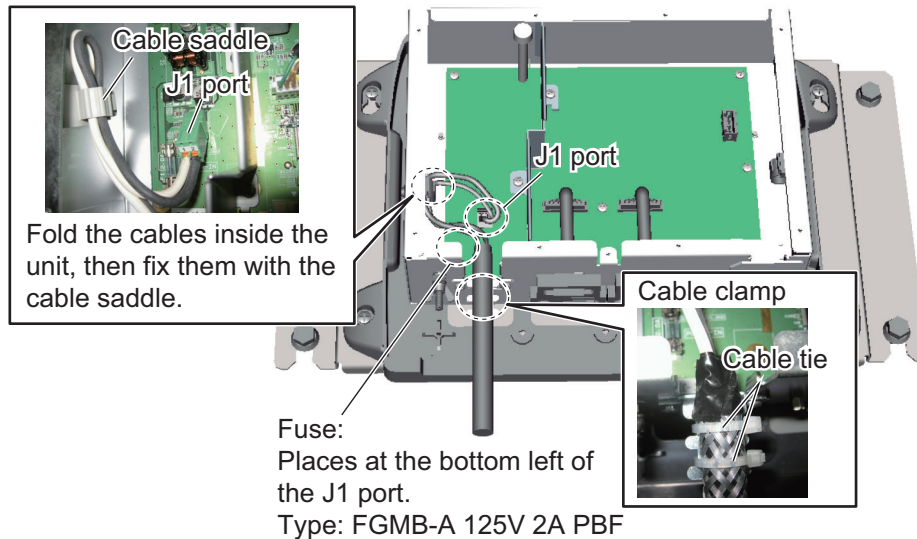

8. Reattach the chassis cover.
9. Connect the DVI-D, RGB, and LAN cables.
10. Fix the LAN cable to the cable clamp with the supplied cable tie.

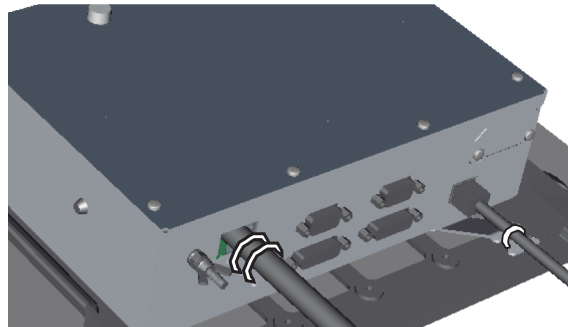

11. Reattach the outside cover.

2.7.4 Connection with a FURUNO radar

Connection with the FAR-21×7/FAR-28×7 series radar

For the connection between the IF-7100 and FAR-21×7/FAR-28×7 series radar, see the respective radar installation manual.

Note: When the FAR-28×7 series radar is connected to the IF-7100, set the DIP switch inside the unit (see section 3.3).

Connection with the FR-21×5 series radar

Prepare the items shown below and modify the FR-21×5 series radar to connect it to the IF-7100.

Name	Type	Part No.	Qty
RGB Buffer Kit • RGB-BUFF Board • NH-XH Connector • NH-XH Connector	OP03-162 • 03P9229A • NH10P-XH13P • NH4P-XH3P	008-501-130	1
Connector Converter	DSUB-BNC-1	001-239-950	1
Analog RGB Cable	KB-HD152K	001-237-500	1

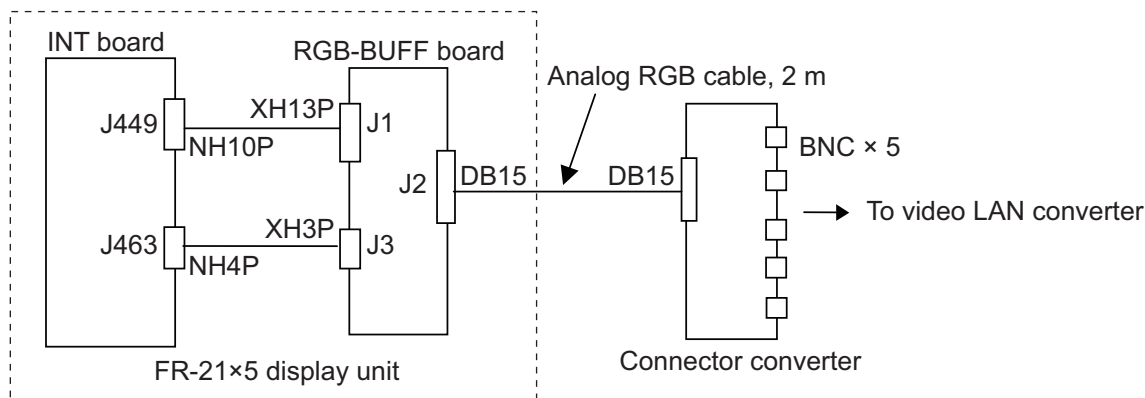

Connection with the FAR-28×5/FR-28×5 series radar

Prepare the items shown below and modify the FAR-28×5/FR-28×5 series radar to connect it to the IF-7100.

Name	Type	Part No.	Qty
VDR I/F Kit 1*1 • RGB-BUFF Board • NH-XH Connector • NH-XH Connector • VDA/INT Chassis	OP03-177 • 03P9229A • 03-2057 (4-3P) • 03-2058 (10-13P) • 03-133-1127-4	008-528-270	1
VDR I/F Kit 2*2 • RGB-BUFF Board • NH-XH Connector • NH-XH Connector	OP03-178 • 03P9229A • 03-2057 (4-3P) • 03-2058 (10-13P)	008-528-280	
Connector Converter	DSUB-BNC-1	001-239-950	1
Analog RGB Cable	KB-HD152K	001-237-500	1

*1: For display unit produced in June 2002 and before.

*2: For display unit produced in June 2002 and after.

2. WIRING

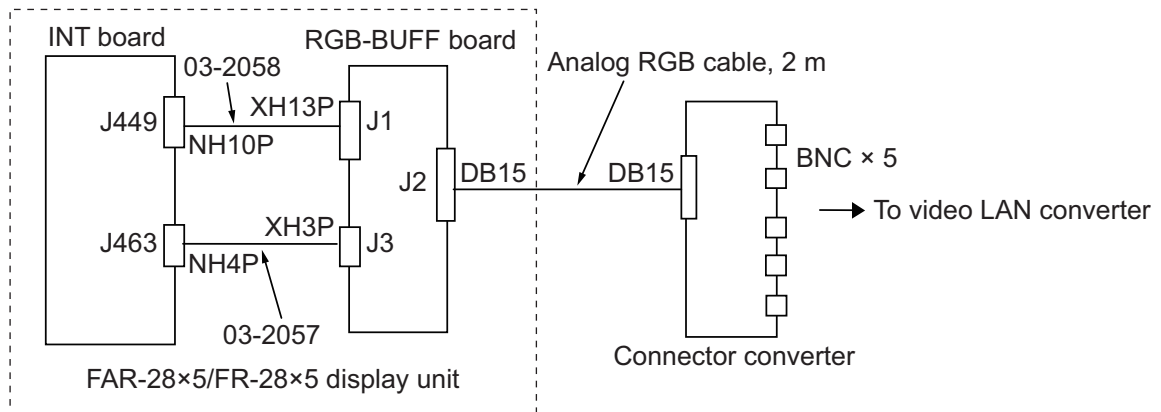

The figure below shows how to mount CPA/TCPA board together with RGB-BUFF board in the FAR-28x5/FR-28x5 series radar. The VDA/INT chassis should be new type, 03-133-1127-4. The CPA/TCPA is powered from #6 (12 V) and #8 (GND) of the power terminal block DTB-2. The J463 port on the INT board is used for the RGB-BUFF board.

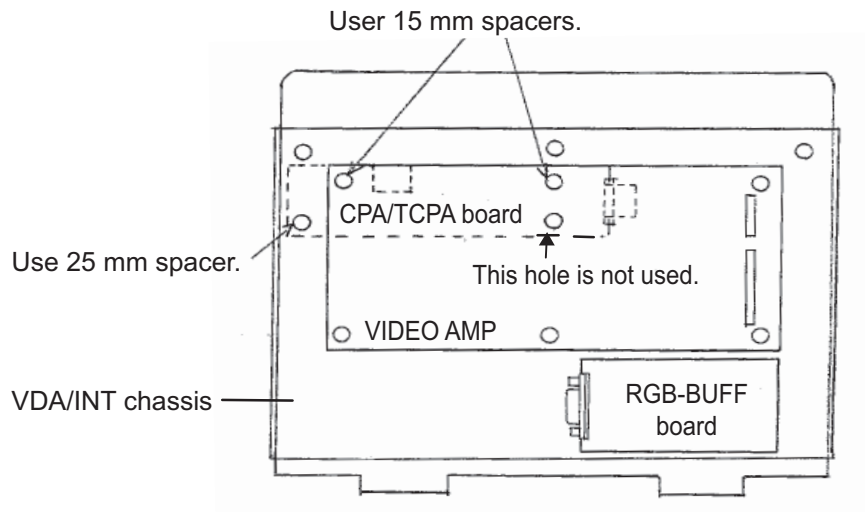

2.8 Sensor Adapters

A maximum of eight MC-3000S can be connected to the DCU through the HUB-100. The MC-3000S can connect a maximum of ten additional units in combination with MC-3010A and MC-3020D, using the MC1.5-W cables. However, note that five MC-3010A can be connected.

When you connect two or more MC-3000S, see the Instruction Manual (OME-44852) to set the MC-3000S.

When fabricating the MC1.5-W cables, use the rod terminal (ferrule type, supplied) to maintain performance. This fabrication requires the optional crimping tool (type: CRIMPFOX 10S).

For how to attach the rod terminal and the relations between the connectors and rod terminals, see "ROD TERMINALS" on page AP-7. Also, the stickers attached on the reverse side of the covers show the detailed connections.

Note 1: Use the MC1.5-W cable between the sensor adapters.

Pin No.	Cable color (MC1.5-W)	Signal
1	Red	24V_OUT or 24V_IN
2	Black	24V_GND
3	White	MODBUS-A
4	Blue	MODBUS-B
5	Gray	GND

Note 2: The total length of the MC1.5-W cables should be less than 6 m to prevent malfunction.

2.8.1 MC-3000S connections

Unfasten four screws to remove the cover, pass the cables through the clamps and attach the cables to respective connectors. The shield part of the cable (or drain wire) must be fastened by (connected to) the clamp. For fabrication of the cables connected to the unit, see appendix 2.

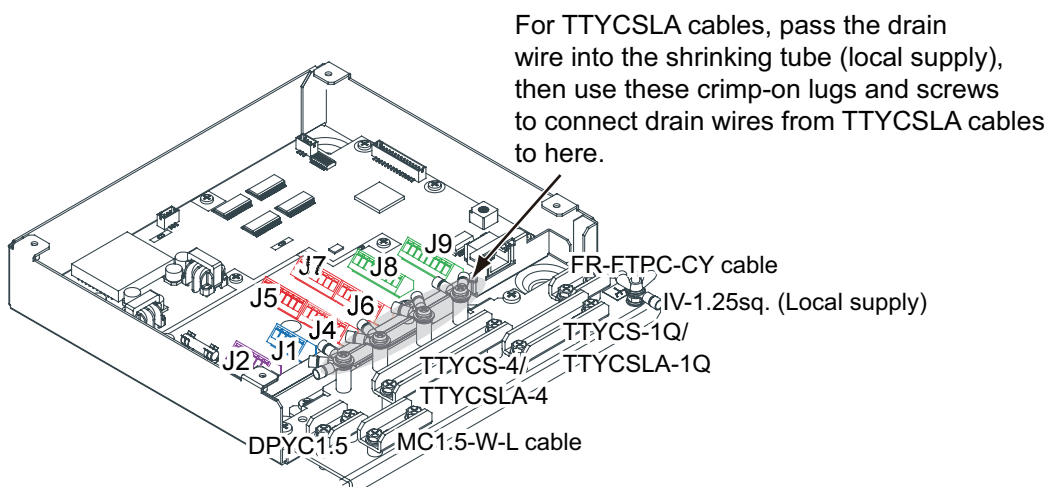

Note: Fasten the cable shield with the cable clamp.

2. WIRING

How to set NC/NO output (J2)

The POWER FAIL signal on the connector J2 can be set to NC (normally closed) output or NO (normally open) output as shown in the table below.

Connector J2

Pin #	Signal name	In/Out	Description	NO	NC
1	24V_IN	-	24 VDC	DPYC-1.5	
2	24V_GND	-	GND (24 VDC)		
3	PWR_FAIL_A	Out	Power fail output	TTYCS(LA)-1	No connection
4	PWR_FAIL_COM	Out	Power fail output		TTYCS(LA)-1
5	PWR_FAIL_B	Out	Power fail output	No connection	

How to set input specification (J4 to J9)

For connectors J4 to J7, the connections are different depending on the input specifications as shown below.

Connector J4

Pin #	Signal name	In/Out	Description	IEC61162-2	IEC61162-1
1	TD1-A	Out	Serial CH1, output IEC61162-1/2/modbus	TTYCS(LA)-4	TTYCS(LA)-4
2	TD1-B	Out	Serial CH1, output IEC61162-1/2/modbus		
3	RD1-A	In	Serial CH1, input IEC61162-2/modbus		No connection
4	RD1-B	In	Serial CH1, input IEC61162-2/modbus		
5	ISOGND1	-	Isolation, GND (CH1)	No connection	TTYCS(LA)-4
6	RD1-H	In	Serial CH1, input IEC61162-1		
7	RD1-C	In	Serial CH1, input IEC61162-1		

Connector J5

Pin #	Signal name	In/Out	Description	IEC61162-2	IEC61162-1
1	TD2-A	Out	Serial CH2, output IEC61162-1/2/modbus	TTYCS(LA)-4	TTYCS(LA)-4
2	TD2-B	Out	Serial CH2, output IEC61162-1/2/modbus		
3	RD2-A	In	Serial CH2, input IEC61162-2/modbus		No connection
4	RD2-B	In	Serial CH2, input IEC61162-2/modbus		
5	ISOGND2	-	Isolation, GND (CH2)	No connection	TTYCS(LA)-4
6	RD2-H	In	Serial CH2, input IEC61162-1		
7	RD2-C	In	Serial CH2, input IEC61162-1		

Connector J6

Pin #	Signal name	In/Out	Description	IEC61162-2	IEC61162-1
1	TD3-A	Out	Serial CH3, output IEC61162-1/2	TTYCS(LA)-4	TTYCS(LA)-4
2	TD3-B	Out	Serial CH3, output IEC61162-1/2		
3	RD3-A	In	Serial CH3, input IEC61162-2		No connection
4	RD3-B	In	Serial CH3, input IEC61162-2		
5	ISOGND3	-	Isolation, GND (CH3)	No connection	TTYCS(LA)-4
6	RD3-H	In	Serial CH3, input IEC61162-1		
7	RD3-C	In	Serial CH3, input IEC61162-1		

Connector J7

Pin #	Signal name	In/Out	Description	IEC61162-2	IEC61162-1
1	TD4-A	Out	Serial CH4, output IEC61162-1/2	TTYCS(LA)-4	TTYCS(LA)-4
2	TD4-B	Out	Serial CH4, output IEC61162-1/2		
3	RD4-A	In	Serial CH4, input IEC61162-2		No connection
4	RD4-B	In	Serial CH4, input IEC61162-2		
5	ISO GND4	-	Isolation, GND (CH4)		
6	RD4-H	In	Serial CH4, input IEC61162-1	No connection	TTYCS(LA)-4
7	RD4-C	In	Serial CH4, input IEC61162-1		

Connector J8

Pin #	Signal name	In/Out	Description	Used cable
1	TD5-A	Out	Serial CH5, output IEC61162-1	TTYCS-1Q or TTYCSLA-1Q
2	TD5-B	Out	Serial CH5, output IEC61162-1	
3	RD5-H	In	Serial CH5, input IEC61162-1	
4	RD5-C	In	Serial CH5, input IEC61162-1	
5	TD6-A	Out	Serial CH6, output IEC61162-1	
6	TD6-B	Out	Serial CH6, output IEC61162-1	
7	RD6-H	In	Serial CH6, input IEC61162-1	
8	RD6-C	In	Serial CH6, input IEC61162-1	

Connector J9

Pin #	Signal name	In/Out	Description	Used cable
1	TD7-A	Out	Serial CH7, output IEC61162-1	TTYCS-1Q or TTYCSLA-1Q
2	TD7-B	Out	Serial CH7, output IEC61162-1	
3	RD7-H	In	Serial CH7, input IEC61162-1	
4	RD7-C	In	Serial CH7, input IEC61162-1	
5	TD8-A	Out	Serial CH8, output IEC61162-1	
6	TD8-B	Out	Serial CH8, output IEC61162-1	
7	RD8-H	In	Serial CH8, input IEC61162-1	
8	RD8-C	In	Serial CH8, input IEC61162-1	

2.8.2 MC-3000S jumper and MODBUS settings

Set the jumper blocks in the MC-CS Board (24P0114) referring to the tables that follow.

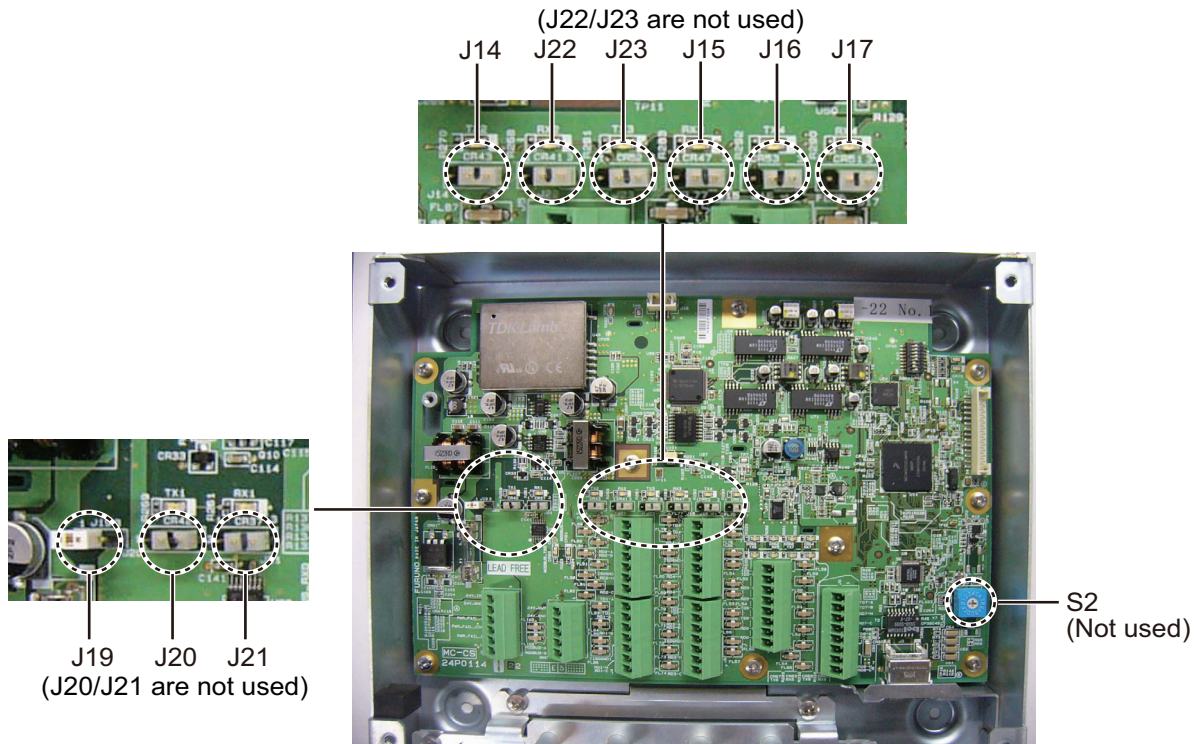

MC-CS Board (24P0114)

Setting termination resistors

Use the jumper block J19 to set the termination resistor on/off for the MODBUS communication on the connector J1. For the first and last sensor adapter in a series, their termination resistors should be set to ON. Use the MC-CS Board with the default setting because it becomes the “first” adapter in a series.

Jumper block J19		Connector J1
1-2	SHORT	Termination resistor: ON (default setting)
2-3	OPEN	
1-2	OPEN	Termination resistor: OFF
2-3	SHORT	

Set the jumper blocks J14 through J17 to turn the termination resistors on connectors J4 through J7 respectively.

(Termination resistor ON)

- When setting the starting/ending terminal for the multipoint, or the multipoint is not connected (CH1 to 4).

(Terminal resistor OFF)

- When setting the terminal other than starting/ending for the multipoint (CH1 to 4).

Jumper block J14		Connector J4 (CH1)
1-2	SHORT	Termination resistor: ON (default setting)
2-3	OPEN	
1-2	OPEN	Termination resistor: OFF
2-3	SHORT	

Jumper block J15		Connector J5 (CH2)
1-2	SHORT	Termination resistor: ON (default setting)
2-3	OPEN	
1-2	OPEN	Termination resistor: OFF
2-3	SHORT	

Jumper block J16		Connector J6 (CH3)
1-2	SHORT	Termination resistor: ON (default setting)
2-3	OPEN	
1-2	OPEN	Termination resistor: OFF
2-3	SHORT	

Jumper block J17		Connector J7 (CH4)
1-2	SHORT	Termination resistor: ON (default setting)
2-3	OPEN	
1-2	OPEN	Termination resistor: OFF
2-3	SHORT	

2.8.3 Case packing for MC-3000S OP24-28 (optional)

The optional kit OP24-28 protects the connectors on the MC-3000S to waterproofing standard IPX2.

Case packing (type: OP24-28, code no.: 001-169-970)

Name	Type	Code No.	Qty
Case packing (serial)	21-014-2051	100-367-880-10	2

1. Unfasten four binding screws to remove the cover from the adapter.

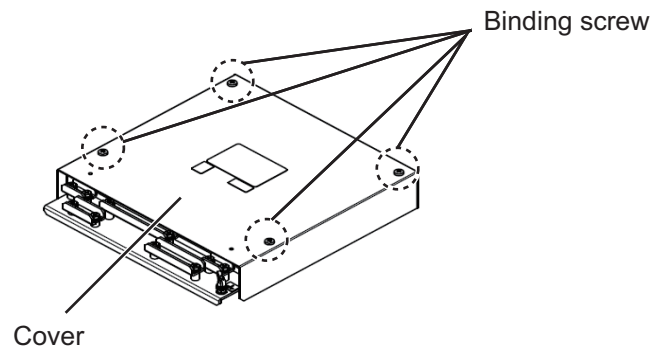

2. Peel the paper from the case packing, then attach the case packing to the reverse side of the cover and the body unit as shown below.

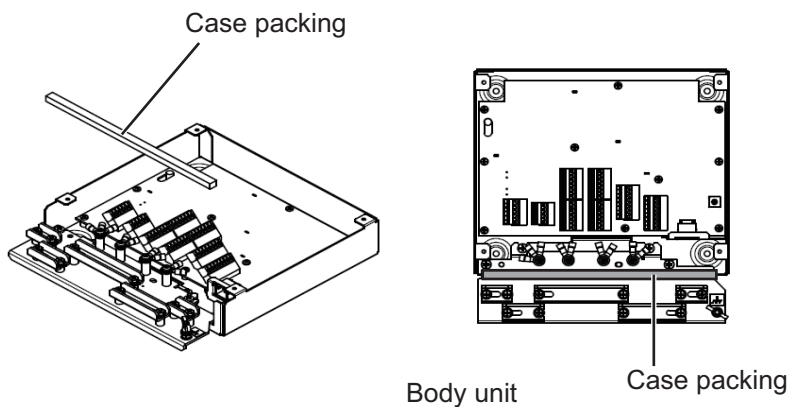
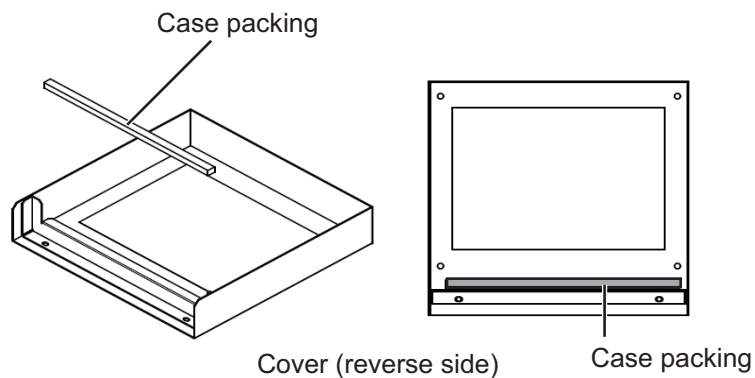

3. Attach the cover to the MC-3000S body unit.

2.8.4 MC-3010A/3020D connections

Unfasten four screws to remove the cover, pass the cables through the clamps and attach the cables to respective connectors. The shield part of the cable (or drain wire) must be fastened by (connected to) the clamp. For fabrication of the cables connected to the unit, see appendix 2.

- MC-3010A: Inputs analog signal. To set MC-3010A to the current input, connect short pins to each terminals.
- MC-3020D: Inputs digital signal (8ch contact input). Contact or voltage input is selectable (contact input requires short pins).

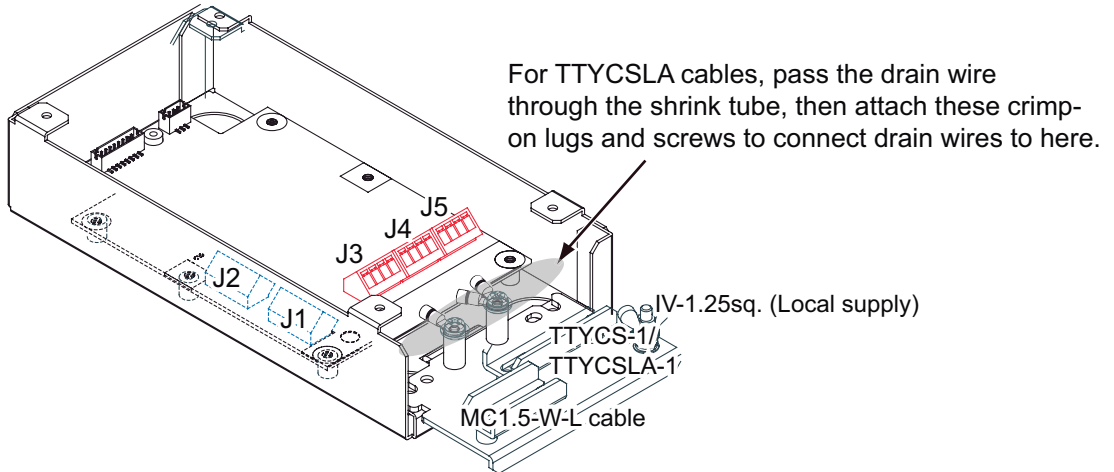

Note: Fasten the cable shield with the cable clamp.

MC-3010A

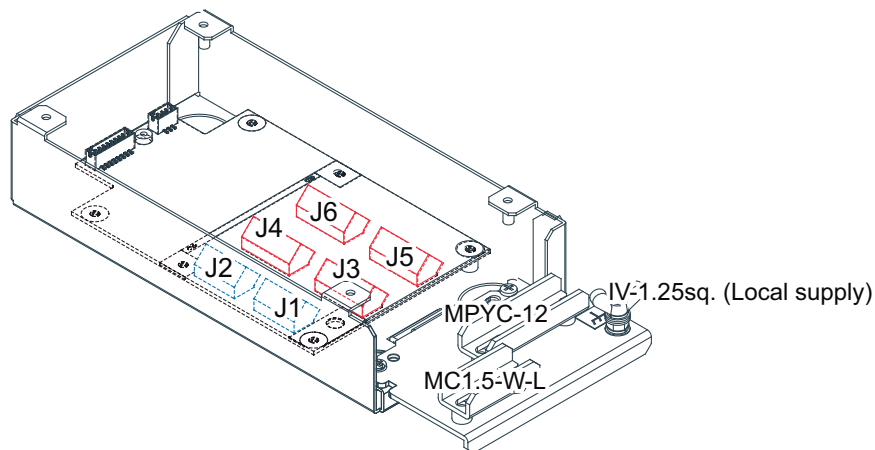

Note: Fasten the cable shield with the cable clamp.

MC-3020D

Input type (MC-3010A)

Select the type of the analog data input, power voltage or power current. When changing the input type, turn off the MC-3010A and on again to put change in effect.

Note 1: For current input, use the AWG wire for jumper.

Note 2: The input must not exceed the range of the input voltage, to prevent malfunction.

-Setting for voltage input: -10 V to +10 V or 0 to 10 V (depending on the setting)

-Setting for current input: 4 mA to 20 mA.

- Power voltage: Input the amount of power voltage change to the operational amplifier.

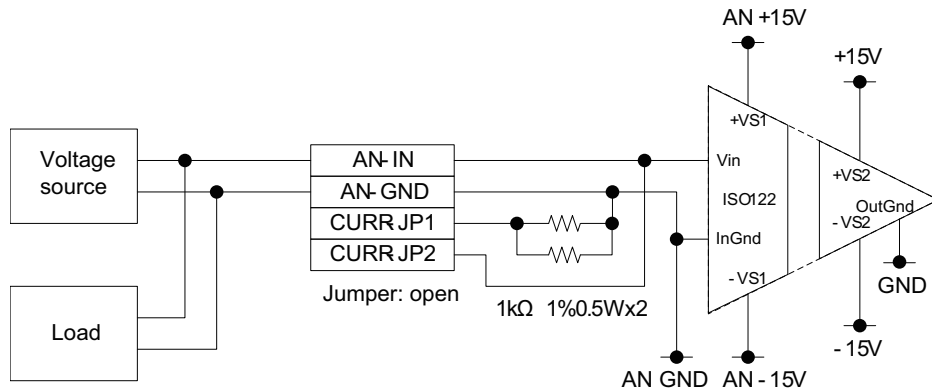

- Power current: Pass the power current to the shunt resistor, 1 k Ω /parallel (combined resistance: 500 Ω) to input the amount of voltage change at the both ends of the resistor to the operational amplifier.

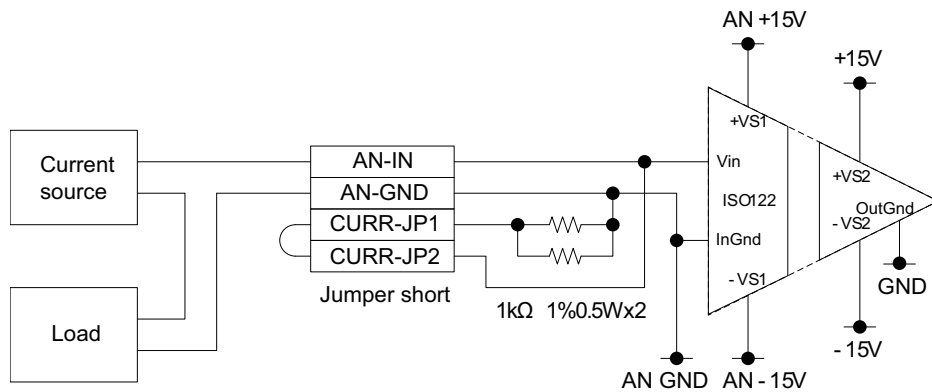

Connector J3

Pin #	Signal name	In/Out	Description	Power voltage	Power current
1	AN1_IN	In	Analog 1 input	TTYCS(LA)-1	
2	AN1_GND	-	Analog 1 GND		
3	CURR1_JP1	-	Analog 1 input, power current/voltage setting jumper 1	Pin #3-#4: open	Pin #3-#4: short
4	CURR1_JP2	-	Analog 1 input, power current/voltage setting jumper 1		

Connector J4

Pin #	Signal name	In/Out	Description	Power voltage	Power current
1	AN2_IN	In	Analog 2 input	TTYCS(LA)-1	
2	AN2_GND	-	Analog 2 GND		
3	CURR2_JP1	-	Analog 2 input, power current/voltage setting jumper 1	Pin #3-#4: open	Pin #3-#4: short
4	CURR2_JP2	-	Analog 2 input, power current/voltage setting jumper 1		

Connector J5

Pin #	Signal name	In/Out	Description	Power voltage	Power current
1	AN3_IN	In	Analog 3 input	TTYCS(LA)-1	
2	AN3_GND	-	Analog 3 GND		
3	CURR3_JP1	-	Analog 3 input, power current/voltage setting jumper 1	Pin #3-#4: open	Pin #3-#4: short
4	CURR3_JP2	-	Analog 3 input, power current/voltage setting jumper 1		

How to set contact input (MC-3020D)

Use the connectors J3 to J6 on the MC-DIN Board (24P0116) to set the contact input. See the tables on the next page.

Note 1: For contact input, use the AWG24 wire for jumper.

Note: The input must not exceed the range of the input voltage, to prevent malfunction.

-Setting for voltage input: 21.6V to 31.2V

-Setting for contact input: Voltage cannot be input (contact signal only).

- Input circuit for voltage input

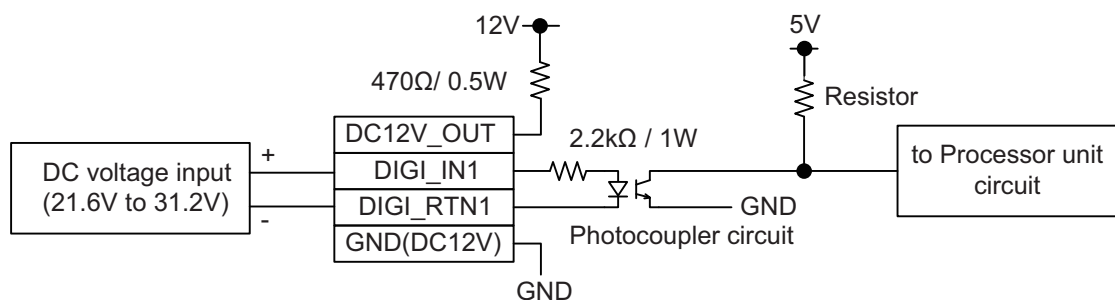

2. WIRING

- Input circuit for contact input

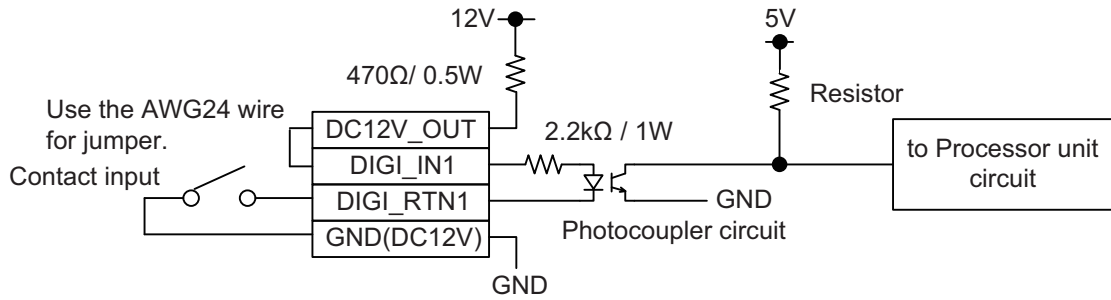

Connector J3

Pin #	Signal name	In/Out	Remarks	ACK1 contact	ACK1 voltage	ACK2 contact	ACK2 voltage
1	DC12V_OUT	Out	ACK1 In	Pin #1-#2: short	No connection	-	
2	DIGI_IN1	In			MPYC-12		
3	DIGI_RT1	Out			MPYC-12		
4	GND (DC12V)	In			No connection		
5	DC12V_OUT	Out	ACK2 In	-	-	Pin #1- #2: short	No connection
6	DIGI_IN2	In				MPYC-12	
7	DIGI_RT2	Out				MPYC-12	
8	GND (DC12V)	In				No connection	

Connector J4

Pin #	Signal name	In/Out	Remarks	ACK3 contact	ACK3 voltage	ACK4 contact	ACK4 voltage
1	DC12V_OUT	Out	ACK3 In	Pin #1-#2: short	No connection	-	
2	DIGI_IN3	In			MPYC-12		
3	DIGI_RT3	Out			MPYC-12		
4	GND (DC12V)	In			No connection		
5	DC12V_OUT	Out	ACK4 In	-	-	Pin #1- #2: short	No connection
6	DIGI_IN4	In				MPYC-12	
7	DIGI_RT4	Out				MPYC-12	
8	GND (DC12V)	In				No connection	

Connector J5

Pin #	Signal name	In/Out	Remarks	ACK5 contact	ACK5 voltage	ACK6 contact	ACK6 voltage
1	DC12V_OUT	Out	ACK5 In	Pin #1-#2: short	No connection	-	
2	DIGI_IN5	In			MPYC-12		
3	DIGI_RT5	Out			MPYC-12		
4	GND (DC12V)	In			No connection		
5	DC12V_OUT	Out	ACK6 In	-	-	Pin #1-#2: short	No connection
6	DIGI_IN6	In				MPYC-12	
7	DIGI_RT6	Out				MPYC-12	
8	GND (DC12V)	In				No connection	

Connector J6

Pin #	Signal name	In/Out	Remarks	ACK7 contact	ACK7 voltage	ACK8 contact	ACK8 voltage
1	DC12V_OUT	Out	ACK7 In	Pin #1-#2: short MPYC-12	No connection		-
2	DIGI_IN7	In			MPYC-12		
3	DIGI_RTN7	Out			No connection		
4	GND (DC12V)	In					
5	DC12V_OUT	Out	ACK8 In		-	Pin #1-#2: short	No connection
6	DIGI_IN8	In				MPYC-12	MPYC-12
7	DIGI_RTN8	Out				No connection	
8	GND (DC12V)	In					

2.8.5 MC-3010A/3020D jumper setting

This section shows how to set the MC-ANLG Board (24P0115, for MC-3010A) and MC-DIN Board (24P0116, for MC-3020D).

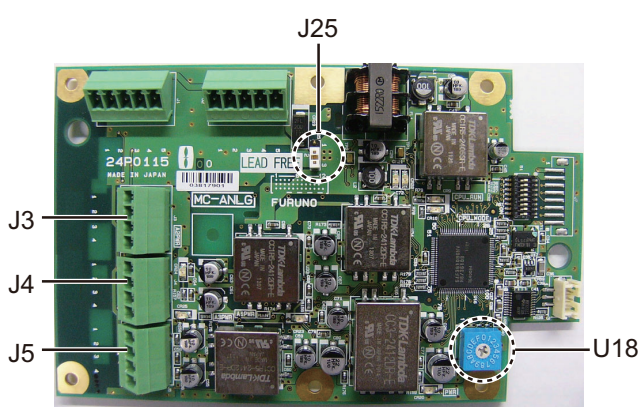

MC-ANLG Board (24P0115)

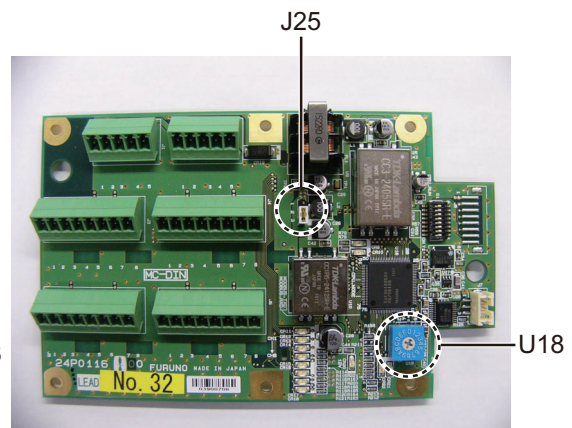

MC-DIN Board (24P0116)

Setting MODBUS addresses

Use the rotary switch U18 to set the MODBUS address with a digit of number from “0”. When multiple sensor adapters are connected to the MC-3000S, the same number cannot be used among them. (The same number can be shared between the MC-3000S and a sensor adapter.)

Setting termination resistors

Use the jumper block J25 to set the termination resistor on/off for the MODBUS communication on the connector J1. For the first and last sensor adapter in a series, their termination resistors should be set to ON. If not, communication between sensor adapters is not possible.

Jumper block J25		Connector J1
1-2	OPEN	Termination resistor: OFF (default setting)
2-3	SHORT	
1-2	SHORT	Termination resistor: ON
2-3	OPEN	

2.8.6 MC-3010A/3020D case packing OP24-29 (optional)

The optional kit OP24-29 protects the connectors on the MC-3010A/3020D to water-proofing standard IPX2.

Case packing (type: OP24-29, code no.: 001-169-960)

Name	Type	Code No.	Qty
Case packing	21-014-2052-2	100-367-961-10	2

1. Unfasten four binding screws to remove the cover from the adapter.

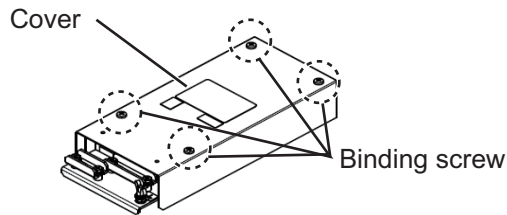

2. Peel the paper from the case packing, then attach the case packing to the reverse side of the cover and the body unit as shown below.

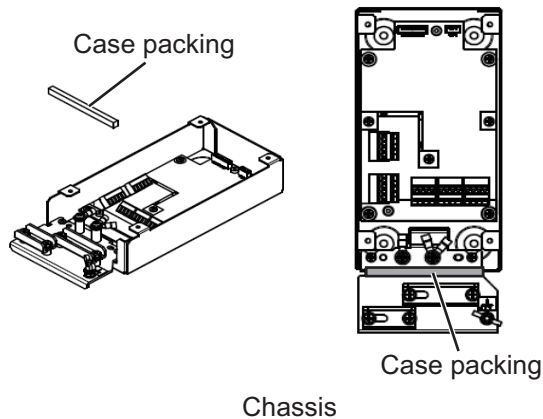
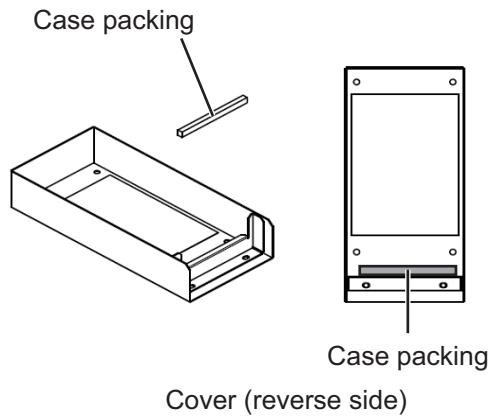

3. Attach the cover to the MC-3010A/3020D chassis.

2.9 Intelligent HUB HUB-3000

Fix the LAN cable connected to the cable clamp using the cable ties (supplied).

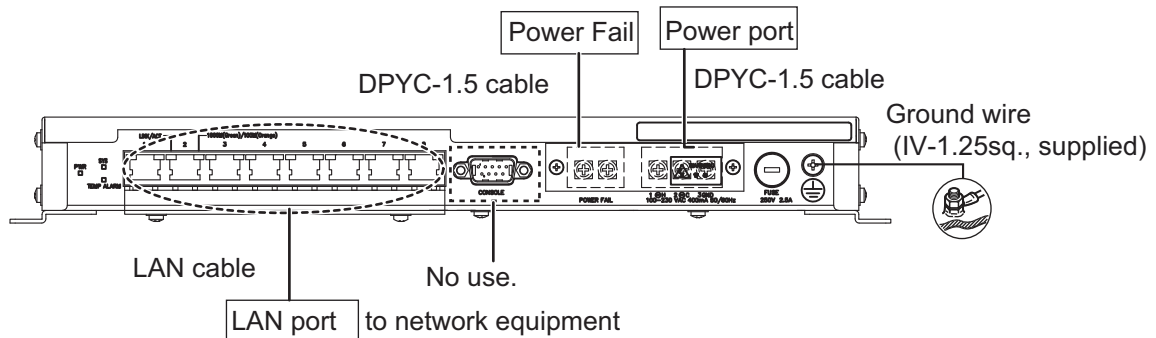

Attach the LAN port cap (supplied) to the unused connector holes to provide waterproofing standard IPX2.

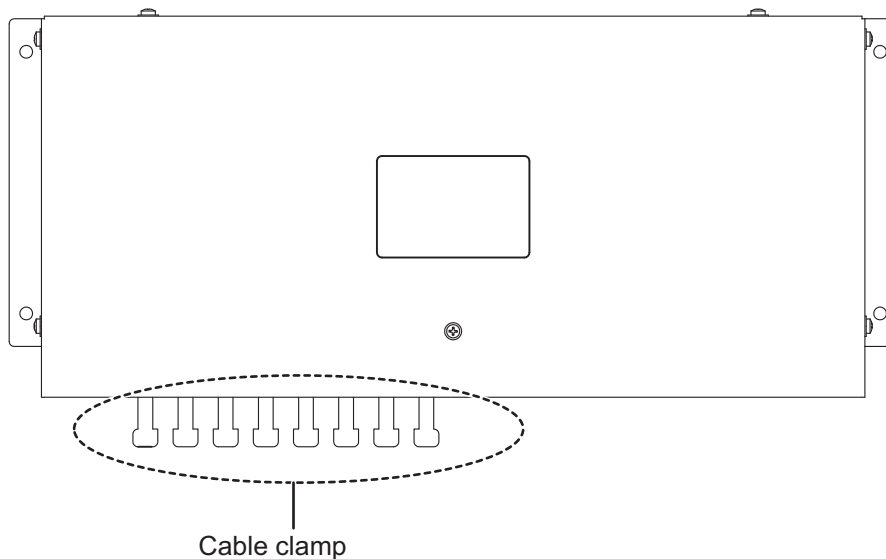

2.10 Power Supply Unit PSU-011

For wiring details, refer to the interconnection diagram at the back of this manual.

1. Unfasten the cable clamp.
2. Remove four screws to remove the cover from the unit.
3. Attach the crimp-on lugs (FV2-4, supplied) to the power cable, then connect between the PSU-011 and J1 port on the DCU.
4. Attach the crimp-on lugs (FV2-4, supplied) to the power cable, then connect between the PSU-011 and power source.
5. Fasten the cable clamp, then reattach the cover.

2.11 Junction Box IF-8530 (Option)

When the junction box IF-8530 is connected to the VDR, update the program version of the junction box to ver. 2450113-01.01 or later. To update the program, prepare the items shown in the table below.

Item	Description
Update program	Download it from Furuno Technet.
Cable between a PC and junction box	Type: JEC9-XH4-#26-L2500, Code No.: 000-170-945-10
Manual for how to update the program	Type: C42-01406-*, Code No.: 000-190-046-1*

The items above and IF-8530 is included in the optional IF-8530 version up kit (OP24-48).

2.11.1 Location of connectors

Connect the serial, analog and digital signals to the terminal boards or connectors in the junction box. Use the 2.5 mm² or AWG14 wires to connect the signals.

For serial and analog signal input, the DIP switch setting is required (see section 2.11.2).

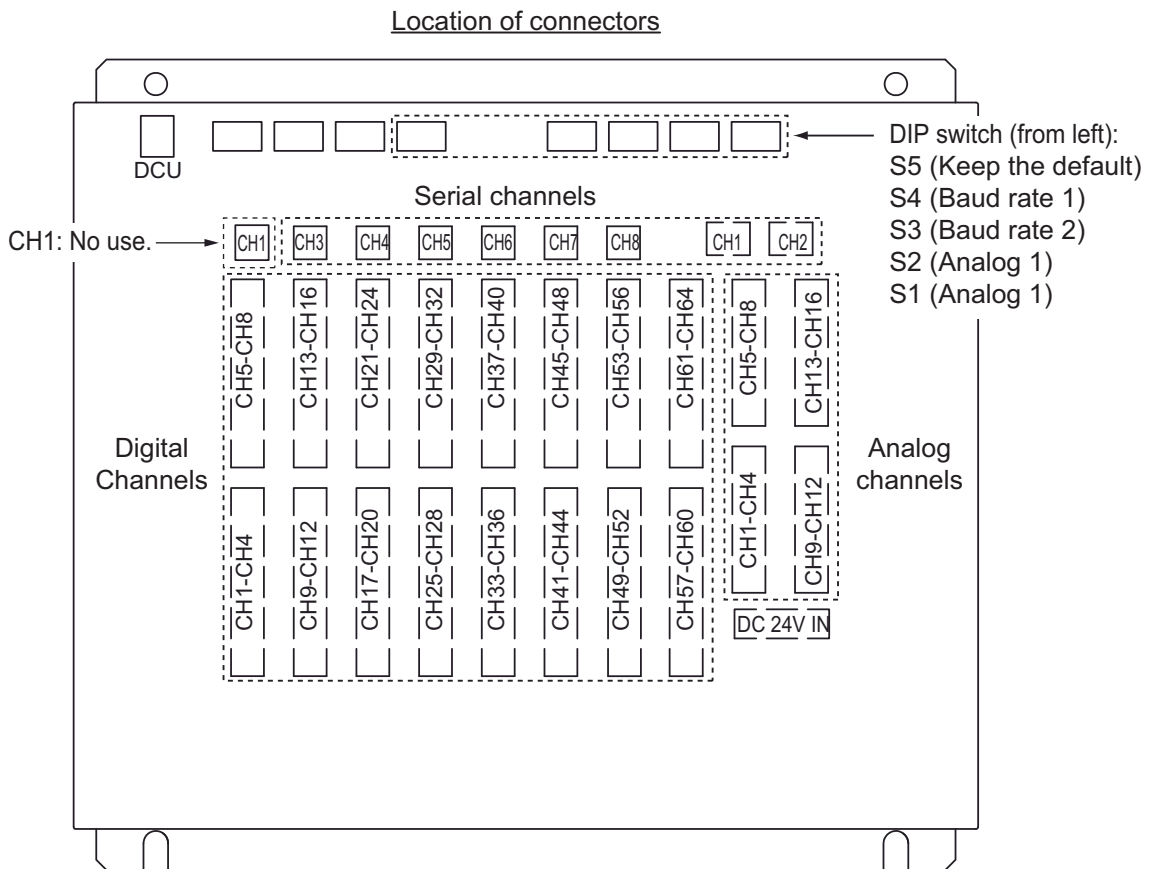

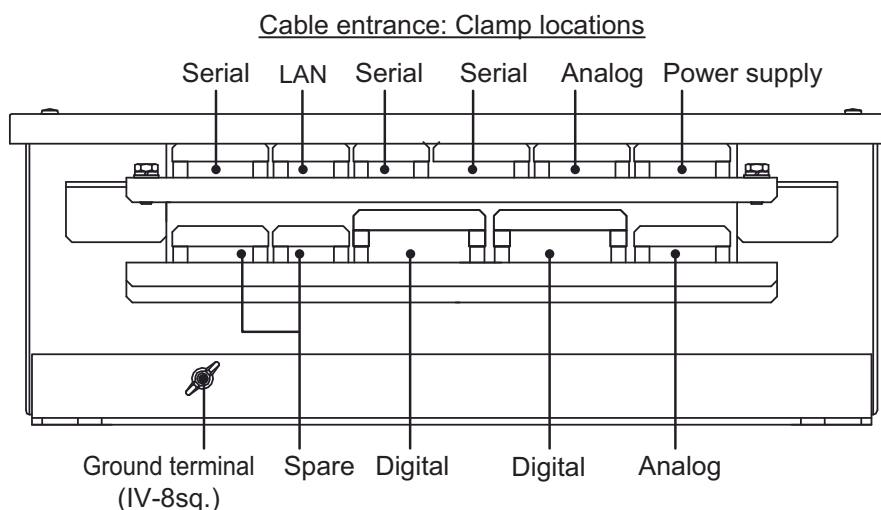

2.11.2 DIP switch setting

Change the DIP switch settings according to serial and analog signal specifications. Turn off the DCU to change the DIP switch settings.

Analog signal (DIP switch S1 and S2)

Channel	SW No.	SW Label	Analog Signal Range Setting	
			-10 V to +10V	0V to +10 V or 4-20 mA
CH1	S2-1	1	OFF	ON
CH2	S2-2	2	OFF	ON
CH3	S2-3	3	OFF	ON
CH4	S2-4	4	OFF	ON
CH5	S2-5	5	OFF	ON
CH6	S2-6	6	OFF	ON
CH7	S2-7	7	OFF	ON
CH8	S2-8	8	OFF	ON
CH9	S1-1	9	OFF	ON
CH10	S1-2	10	OFF	ON
CH11	S1-3	11	OFF	ON
CH12	S1-4	12	OFF	ON
CH13	S1-5	13	OFF	ON
CH14	S1-6	14	OFF	ON
CH15	S1-7	15	OFF	ON
CH16	S1-8	16	OFF	ON

Serial data baud rate (DIP switch S3 and S4)

Channel	SW No.	SW Label	Serial Baud Rate Setting			
			4800 bps	9600 bps	19200 bps	38400 bps
CH1*1	S4-1	1A	OFF	-	-	ON
	S4-2	1B	OFF	-	-	ON
CH2*1	S4-3	2A	OFF	-	-	ON
	S4-4	2B	OFF	-	-	ON
CH3*2	S4-5	3A	OFF	ON	OFF	-
	S4-6	3B	OFF	OFF	ON	-
CH4*2	S4-7	4A	OFF	ON	OFF	-
	S4-8	4B	OFF	OFF	ON	-
CH5*2	S3-1	5A	OFF	ON	OFF	-
	S3-2	5B	OFF	OFF	ON	-
CH6*2	S3-3	6A	OFF	ON	OFF	-
	S3-4	6B	OFF	OFF	ON	-
CH7*2	S3-5	7A	OFF	ON	OFF	-
	S3-6	7B	OFF	OFF	ON	-
CH8*2	S3-7	8A	OFF	ON	OFF	-
	S3-8	8B	OFF	OFF	ON	-

*1: IEC61162-1/2, *2: IEC61162-1

2.12 IP Addresses of the Unit

The IP addresses of each unit are shown below.

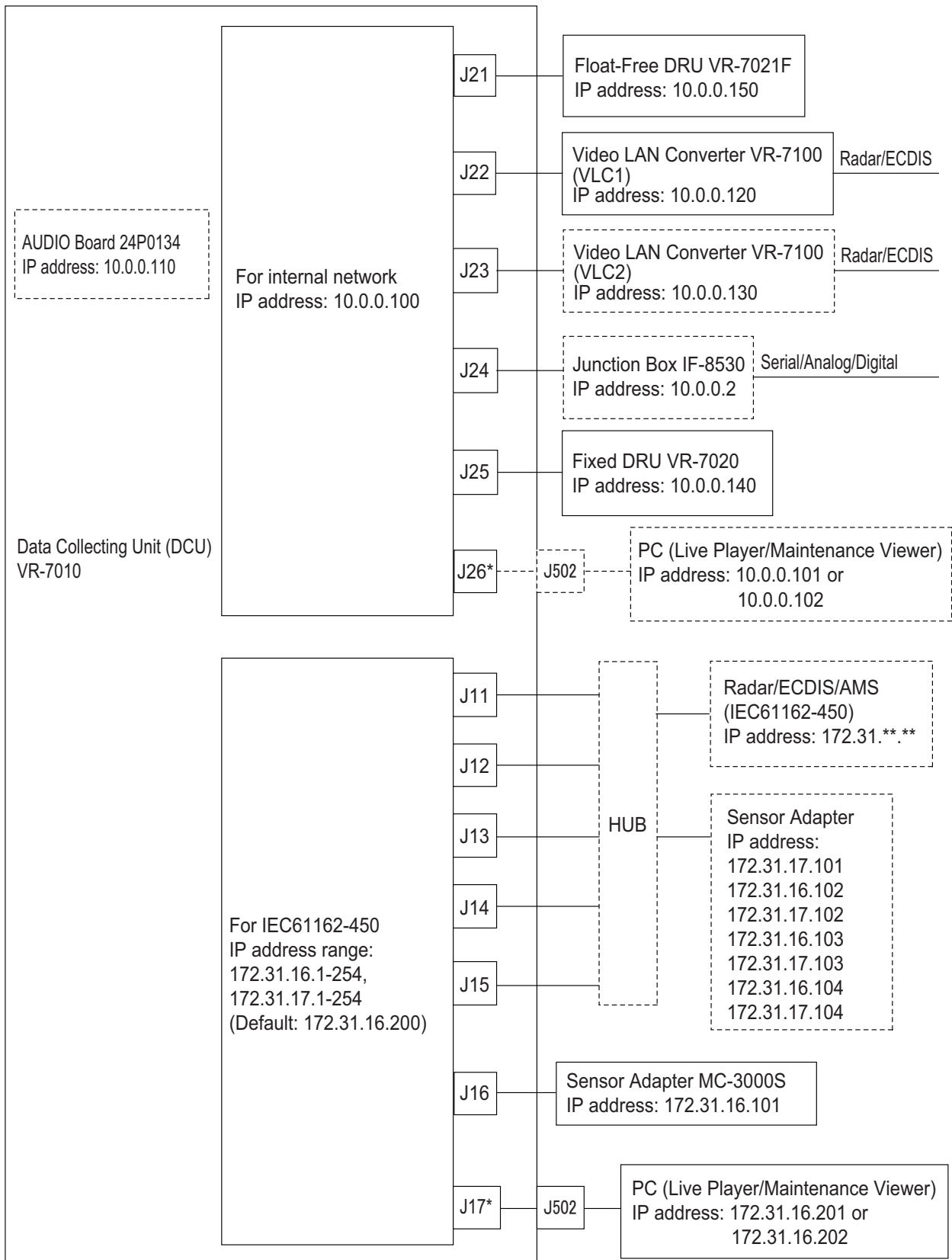

*: The J502 port (DATA) is connected to the J17 port internally in default. When you input the radar/ECDIS video signal with the IEC61162-450 (LAN) format, disconnect the LAN cable from the J17 port and connect it to the J26 port (see section 2.1.4).

2. WIRING

This page is intentionally left blank.

3. SETTING UP THE EQUIPMENT

After installing the VR-7000/7000S, configure the system. For details, see the manual for VDR Maintenance Viewer and Live Player V5.

The outline of the setup is as below.

- Step 1. Network setting on PC and VDR
- Step 2. Software setting
- Step 3. Backup data setting
- Step 4. Software configuration from file data
- Step 5. Media management
- Step 6. Other functions

After setting up, save a backup copy of the configuration data to both a CompactFlash (CF) in the DCU and the PC that has the VDR Maintenance Viewer.

3.1 System Time Adjustment

The system time, used for time-stamping VDR data, synchronizes with the UTC time if the system time is behind the UTC time within 10 seconds. After installing the VR-7000/7000S, do the procedure below to set the system time within 10 seconds behind the UTC time.

1. Remove seven binding screws to detach the cover from the DCU.
2. Connect a VGA monitor and keyboard to the DCU.

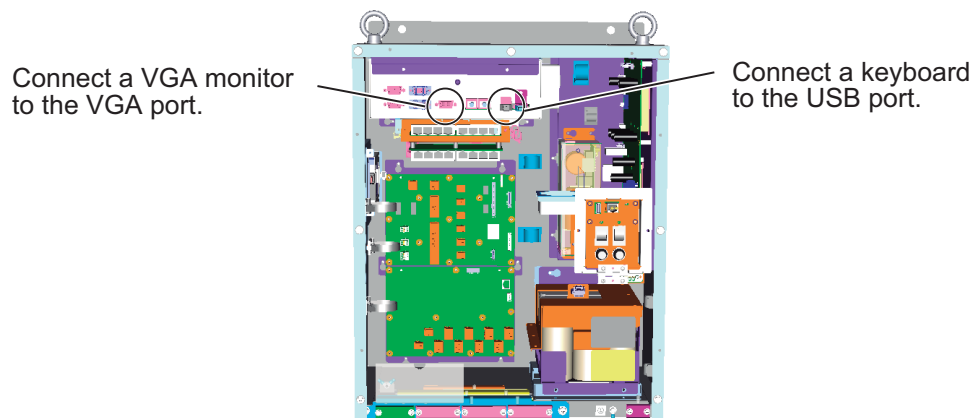

3. Turn on the system while pressing and holding down the **F2** key.
4. Wait until the BIOS display appears. (Keep the **F2** key pressed.)
5. Set the system time within 10 seconds behind the UTC time.
6. Press the **F10**, **Y**, and **Enter** keys in order to save data.
7. Reboot the system.
8. Confirm that the system time is within 10 seconds behind the UTC time.

3.2 Recording Expiration Date of Parts

After installing and setting up the system, cut out (or copy and cut) the expiration data sheet provided below. Then record the date of expiration date of each item on the sheet.

For VR-7000S systems, record the expiration date for either the VR-7020 or the VR-7021F, as appropriate.

Interval-specific parts	Life	Date of expiration
Battery in DCU	4 years	
Hydrostatic release unit in float-free DRU	2 years	
Battery in float-free DRU	5 years	
Battery in the beacon of fixed DRU	3 years	

- Battery in DCU

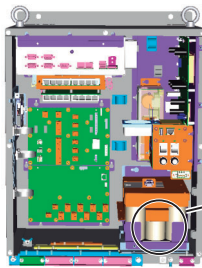

Size	xxx-xxxx-xx
Date	xx xx xx*
S.NO	xxxxxxxx

This date is production date. Install within 18 months after the date.

Record the installation date + four years.

- Battery in float-free DRU

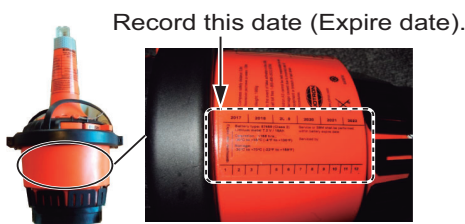

- Hydrostatic release unit in float-free DRU

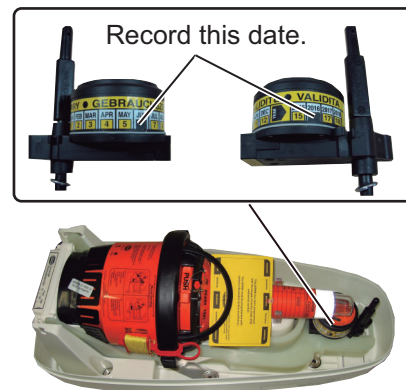

- Battery in the beacon of fixed DRU

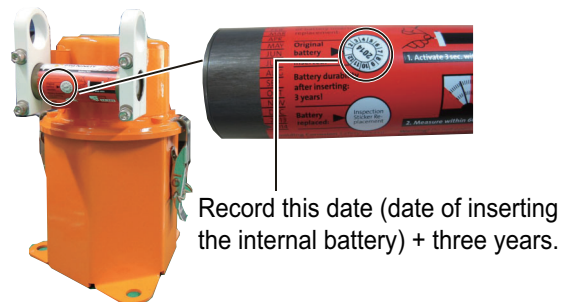

After recording the date of expiration, place the sheet in the card holder on the rear side of the DCU cover. In addition, enter the expiration date information to the VDR, using the Maintenance Viewer program. For how to enter the information, see the operator's manual of the Maintenance Viewer (OME-44852).

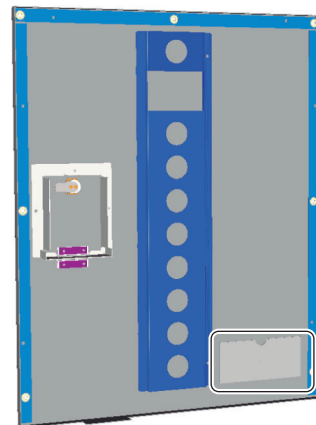

Card holder

Rear side of the DCU cover

3.3 DIP Switch Setting in Video LAN Converter

Set the DIP switch (S1) in the cases shown below.

- When two video LAN converters are installed:
Turn on the S1-1 in the No.2 video LAN converter (No.2 VLC).
- When the RGB1 or RGB2 port is used:
Turn on the S1-3 (RGB1) or S1-4 (RGB2) when you input the video signal of the FAR-28×7 series radar (resolution: 1360×1024) to the RGB port.

The location and setting of the DIP switch are shown below.

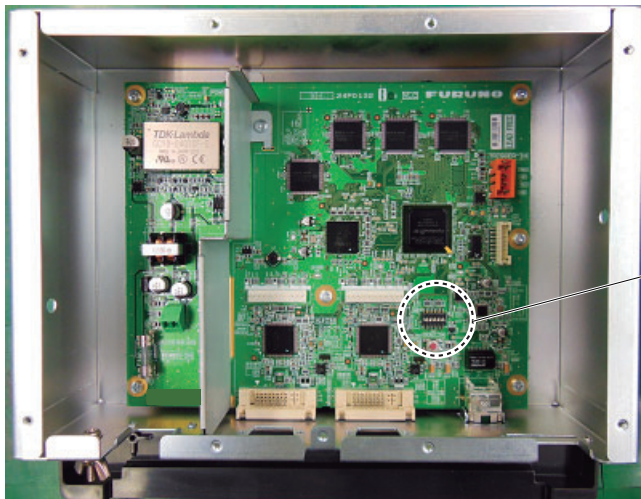

Inside view of the video LAN converter



Dip SW	S1-1	S1-2	S1-3	S1-4	S1-5 to S1-8
ON	No.2 VLC	Used for maintenance.	For inputting the video signal of the FAR-28×7 series radar (resolution: 1360×1024) to the RGB1 port.	For inputting the video signal of the FAR-28×7 series radar (resolution: 1360×1024) to the RGB2 port.	No use.
OFF (Default setting)	No.1 VLC	Normal operation.	For inputting the video signal of the FAR-21×7 series radar or other model to the RGB1 port.	For inputting the video signal of the FAR-21×7 series radar or other model to the RGB2 port.	Normal operation.

3.4 How to Configure the VR-7000S

This procedure is for VR-7000S (Program version 1.10 and later) systems, in case of a VR-7000 system, skip this procedure.

Note: If you purchased a VR-7000S without capsule, remove the wheel label attached on the Data Collecting Unit.

1. Start the VDR Maintenance Viewer.
2. From the menu, select [Maintenance], [VDR Config Management], [Download]. Click the [OK] button twice then the [Close] button.
3. Click the [System] tab.
4. Select the VR-7000S in the [VDR Type].
5. Put a check in check box for [Fixed DRU Connection] (VR-7020) or [Float DRU Connection] (VR-7021F) as appropriate for your system configuration. [Fixed DRU Connection] is checked by default.
6. Confirm that [SAVE Function] is checked. This field is not checked if VR-7000 is selected step 4.
7. Click the [Set] button.
8. From the menu, select [Maintenance], [VDR Config Management], [Upload].
9. A confirmation window appears; click the [OK] button to start uploading to the VDR.
10. Click the [Write] button.
11. The message "VDR will be rebooted. Continue?" appears. Click the [OK] button to continue. You are then logged out of the Maintenance Viewer. The reboot takes several minutes.
12. After the reboot, press the **MENU/ESC** key to open the main menu on the base screen of the RAP (Remote Alarm Panel).
13. Use the cursorpad (**▲** or **▼**) to select [Settings], [Servicemen Settings] in order. [Enter Password] pop-up window appears.
14. Press **▲**, **▼**, **◀**, **▶**, **MENU/ESC**, **ENT** in order. [SAVE Function] pop-up window appears.
15. Use the cursorpad (**◀** or **▶**) to select [ON] then press the **ENT** key.
Note 1: Using the VR-7000S, make the [SAVE Function] active.
Note 2: About the [SAVE Function], if each setting between DCU and RAP is different, the alert appears. Using the VR-7000, make the [SAVE Function] inactive. Using the VR-7000S, make the [SAVE Function] active.
Note 3: If you select the different recording unit step 5 from the recording unit actually installed, the alert appears. Select the correct recording unit step 5.

3.5 Timeout Settings for Serial Input Signal

Be sure to set the timeout settings for all serial channels. If the timeout setting is not adjusted, the serial communication error alert does not occur when serial connected equipment is disconnected.

You can adjust the timeout settings from the Maintenance Viewer*. The timeout settings must be higher than the transmission rate of the connected equipment.

After completing the timeout settings, it is recommended that you make a copy of the following table and make a note of the settings, then put the table on a wall near the remote alarm panel.

*: For how to use the Maintenance Viewer, see the Instruction Manual (OME-44852).

VDR Serial Input Signal List

Serial CH No.	Equipment Name	Timeout Setting
01		
02		
03		
04		
05		
06		
07		
08		
09		
10		
11		
12		
13		
14		
15		
16		

3. SETTING UP THE EQUIPMENT

This page is intentionally left blank.

APPENDIX 1 JIS CABLE GUIDE

Cables listed in the manual are usually shown as Japanese Industrial Standard (JIS). Use the following guide to locate an equivalent cable locally.

JIS cable names may have up to 6 alphabetical characters, followed by a dash and a numerical value (example: DPYC-2.5).

For core types D and T, the numerical designation indicates the *cross-sectional Area (mm²)* of the core wire(s) in the cable.

For core types M and TT, the numerical designation indicates the *number of core wires* in the cable.

1. Core Type

D: Double core power line
 T: Triple core power line
 M: Multi core
 TT: Twisted pair communications
 (1Q=quad cable)

2. Insulation Type

P: Ethylene Propylene Rubber

3. Sheath Type

Y: PVC (Vinyl)

4. Armor Type

C: Steel

5. Sheath Type

Y: Anticorrosive vinyl sheath

6. Shielding Type

S: All cores in one sheath
 -S: Individually sheathed cores
 SLA: All cores in one shield, plastic tape w/aluminum tape
 -SLA: Individually shielded cores, plastic tape w/aluminum tape



DPYC



TPYC

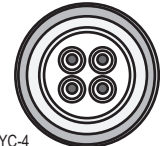

MPYC-4

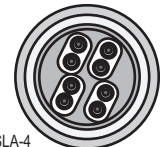

TTYCSLA-4

EX: ^{1 2 3 4 5 6} TTYCYSLA - 4
 Designation type | Core Area (mm²)

EX: ^{1 2 3 4} MPYC - 4
 Designation type | # of cores

The following reference table lists gives the measurements of JIS cables commonly used with Furuno products:

Type	Area	Core Diameter	Cable Diameter	Type	Area	Core Diameter	Cable Diameter
DPYC-1.5	1.5mm ²	1.56mm	11.7mm	TTYCS-1	0.75mm ²	1.11mm	10.1mm
DPYC-2.5	2.5mm ²	2.01mm	12.8mm	TTYCS-1T	0.75mm ²	1.11mm	10.6mm
DPYC-4	4.0mm ²	2.55mm	13.9mm	TTYCS-1Q	0.75mm ²	1.11mm	11.3mm
DPYC-6	6.0mm ²	3.12mm	15.2mm	TTYCS-4	0.75mm ²	1.11mm	16.3mm
DPYC-10	10.0mm ²	4.05mm	17.1mm	TTYCSLA-1	0.75mm ²	1.11mm	9.4mm
DPYCY-1.5	1.5mm ²	1.56mm	13.7mm	TTYCSLA-1T	0.75mm ²	1.11mm	10.1mm
DPYCY-2.5	2.5mm ²	2.01mm	14.8mm	TTYCSLA-1Q	0.75mm ²	1.11mm	10.8mm
DPYCY-4	4.0mm ²	2.55mm	15.9mm	TTYCSLA-4	0.75mm ²	1.11mm	15.7mm
MPYC-2	1.0mm ²	1.29mm	10.0mm	TTYCY-1	0.75mm ²	1.11mm	11.0mm
MPYC-4	1.0mm ²	1.29mm	11.2mm	TTYCY-1T	0.75mm ²	1.11mm	11.7mm
MPYC-7	1.0mm ²	1.29mm	13.2mm	TTYCY-1Q	0.75mm ²	1.11mm	12.6mm
MPYC-12	1.0mm ²	1.29mm	16.8mm	TTYCY-4	0.75mm ²	1.11mm	17.7mm
TPYC-1.5	1.5mm ²	1.56mm	12.5mm	TTYCY-4S	0.75mm ²	1.11mm	21.1mm
TPYC-2.5	2.5mm ²	2.01mm	13.5mm	TTYCY-4SLA	0.75mm ²	1.11mm	19.5mm
TPYC-4	4.0mm ²	2.55mm	14.7mm	TTYCYS-1	0.75mm ²	1.11mm	12.1mm
TPYCY-1.5	1.5mm ²	1.56mm	14.5mm	TTYCYS-4	0.75mm ²	1.11mm	18.5mm
TPYCY-2.5	2.5mm ²	2.01mm	15.5mm	TTYCYSLA-1	0.75mm ²	1.11mm	11.2mm
TPYCY-4	4.0mm ²	2.55mm	16.9mm	TTYCYSLA-4	0.75mm ²	1.11mm	17.9mm

APPENDIX 2 CABLE FABRICATION

Fabrication of DPYC cable

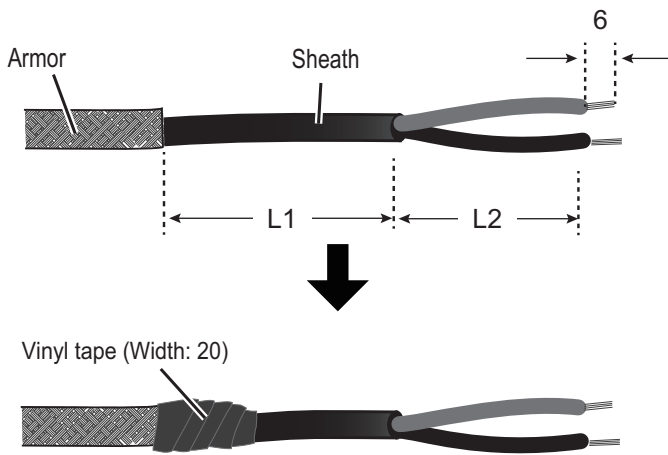

Fabrication of DPYCY cable

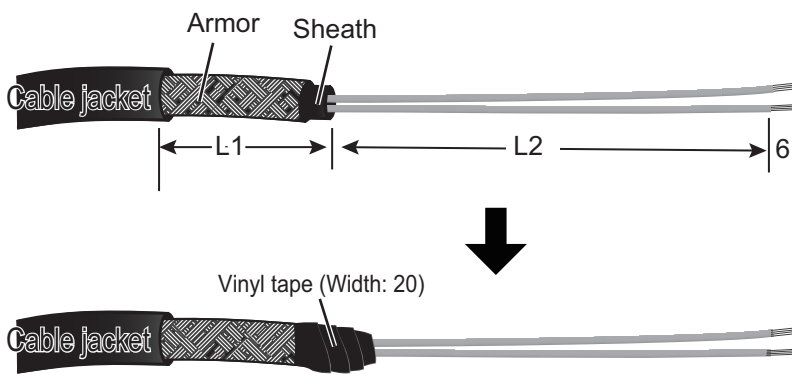

Fabrication of TTYCSLA cable

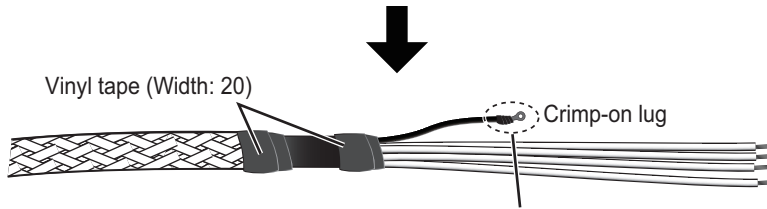
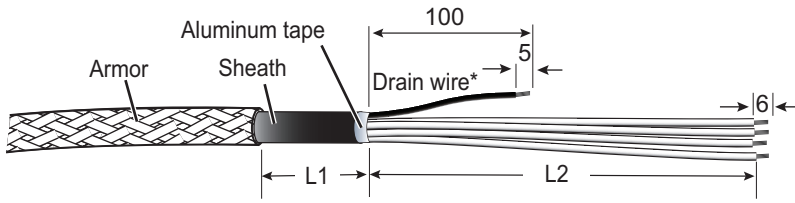

Pass the heat shrinkable (local supply) onto the drain wire*, then attach the crimp-on lug to it.

*: The drain wire is not required for the access points shown below.

Access point	
Unit	Connector No.
VR-7010	J301-J308
	J201-J210
VR-7011	J1

Fabrication of TTYCYSLA cable

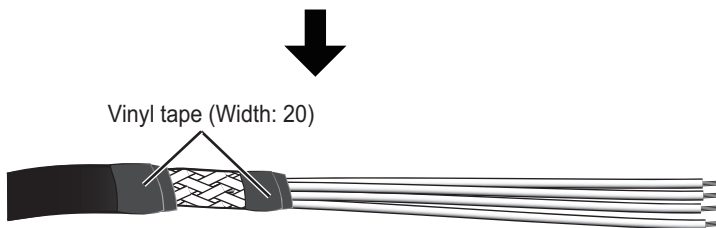
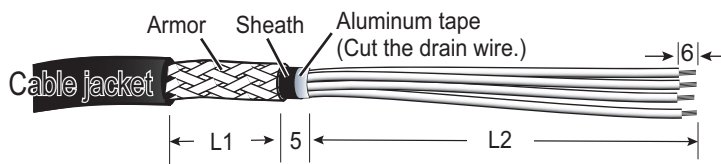

Fabrication of MC1.5-W-L cable

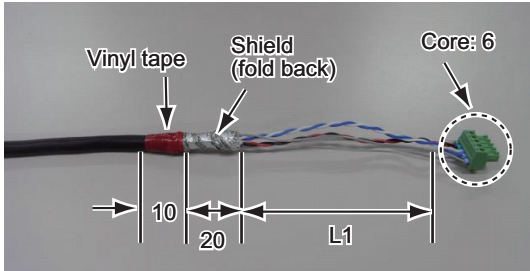

Fabrication of MPYC-12 cable (MC-3020D)

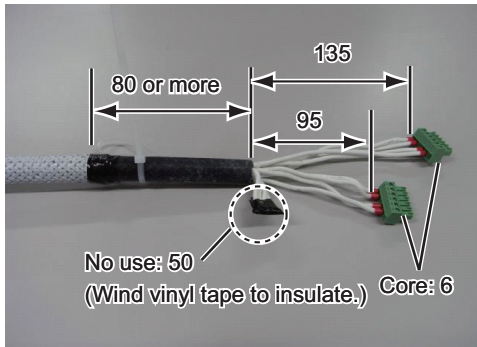

How to connect wires to the WAGO connector

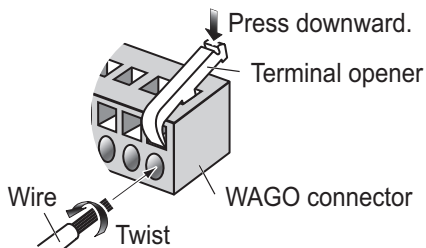

- <Procedure>
1. Twist the cores.
 2. Press the terminal opener downward.
 3. Insert the wire to hole.
 4. Remove the terminal opener.
 5. Pull the wire to confirm that it is secure.

The terminal opener is preattached inside of the DCU. See the figure below.

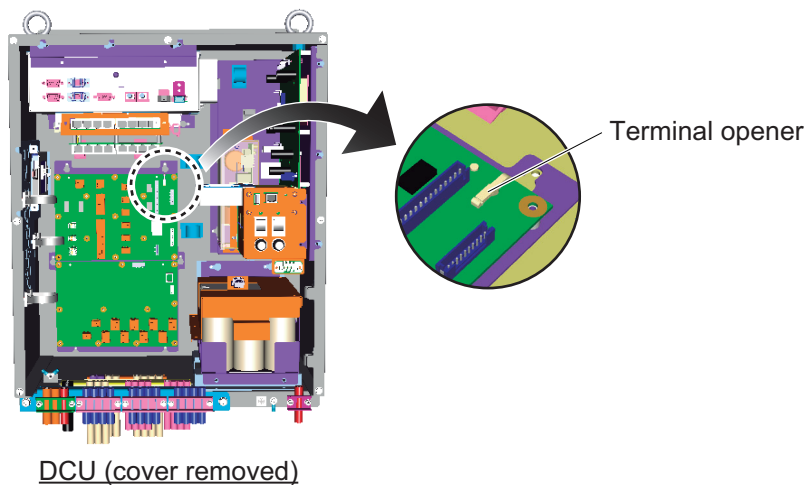

You can use the slotted head screwdriver instead of the terminal opener.

Fabrication of the LAN cable

•For VR-7010

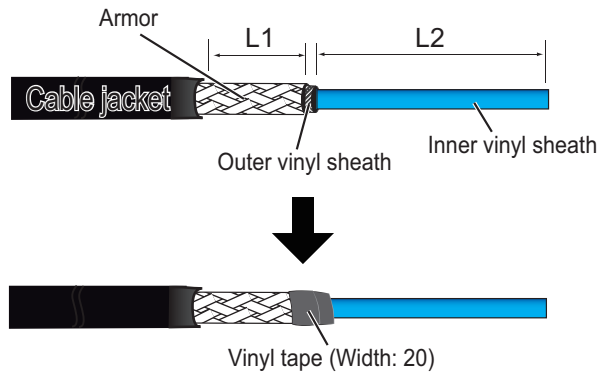

•For other units

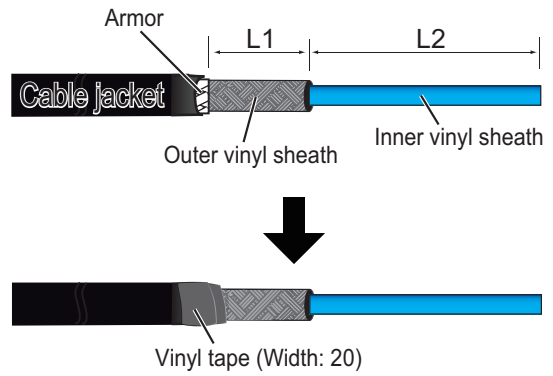

1 Expose inner vinyl sheath.

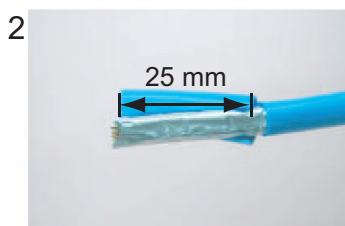

2 Remove the inner vinyl sheath by approx 25 mm. Be careful not to damage inner shield and cores.

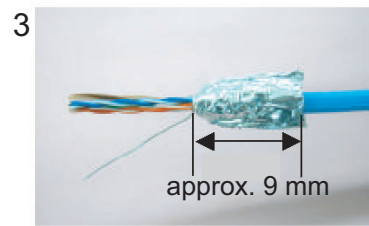

3 Fold back the shield, wrap it onto the inner vinyl sheath and cut it, leaving 9 mm.

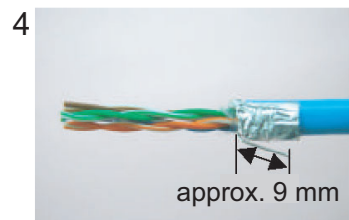

4 Fold back drain wire and cut it, leaving 9 mm.

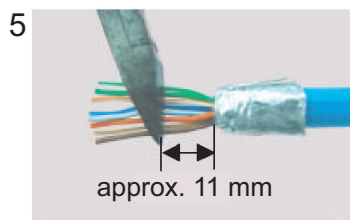

5 Straighten and flatten the core in order and cut them, leaving 11 mm.



6 Insert the cable into the modular plug so that the folded part of the shield enters into the plug housing. The drain wire should be located on the tab side of the jack.



7 Using special crimping tool MPT5-8AS (PANDUIT CORP.), crimp the modular plug. Finally check the plug visually.

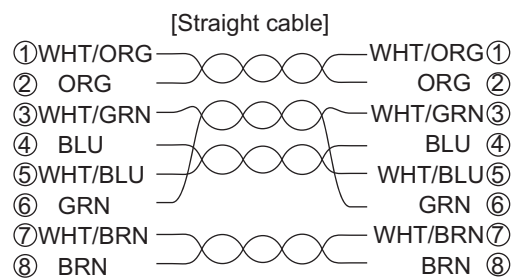
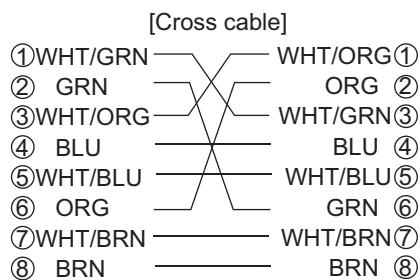
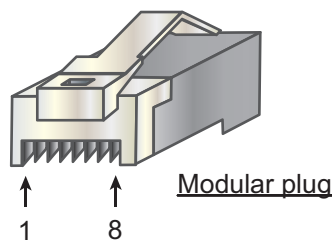

APPENDIX 2 CABLE FABRICATION

The length of “L”

The length of “L1” and “L2” in the figure on AP-2 to AP-5 page is shown below.

Cable	Access point		The length of “L”	
	Unit	Connector No.	L1	L2
DPYC cable	VR-7010	J1	0 mm	More than 200 mm
		J313	0 mm	More than 350 mm
	IF-7100	J1	0 mm	220 mm
	MC-3000S	J2	80 mm	85 mm
DPYCY cable	VR-7010	J311-J312	30 mm	More than 350 mm
TTYCSLA cable	VR-7010	J309	0 mm	500 mm
		J310	0 mm	500 mm
		J301-J308	0 mm	500 mm
		J201-J202	0 mm	500 mm
		J203-J208	0 mm	250 mm
	VR-7011	J1	0 mm	50 mm
	VR-7017	J101	30 mm	100 mm
	MC-3000S	J2	80 mm	100 mm
		J4/J6	80 mm	100 mm
		J5/J7	80 mm	120 mm
		J8	80 mm	#1 to 4: 100 mm #5 to 8: 95 mm
		J9	80 mm	#1 to 4: 100 mm #5 to 8: 90 mm
	MC-3010A	J3-J5	80 mm	60 mm
TTYCYSLA cable	VR-7010	J209-J210	30 mm	250 mm
	VR-7012W	J1	See section 1.6.	
FR-FTPC-CY cable	VR-7010	J11-J16	30 mm	725 mm
		J21-J26	30 mm	725 mm
	IF-7100	J4	0 mm	55 mm
	MC-3000S	J3	50 mm	55 mm
MC1.5-W-L cable	MC-3000S	J1	110 mm	-
	MC-3010A/ MC-3020D	J1	120 mm	-
		J2	100 mm	-

APPENDIX 3 ROD TERMINALS

How to attach the rod terminal (ferrule type)

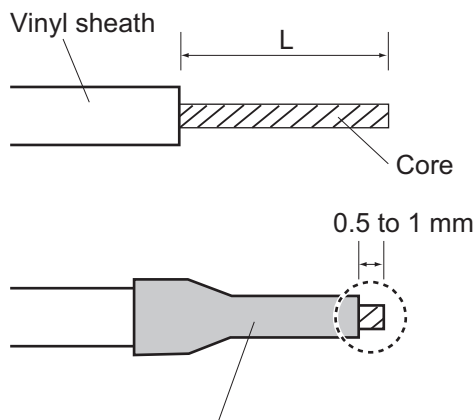

Rod terminal	The length of "L"
AI 1.5-6 BK (black)	6 mm
AI 0.34-6 TQ (blue)	
AI 0.75-6 GY (gray)	
AI 1-6 RD (red)	8 mm
AI 0.14-8 GY (gray)	
A 1.5-10	10 mm

Rod terminal (ferrule type):
After attaching the rod terminal, use the optional crimping tool CRIMPFOX 10S to crimp.

VR-7010 (AC IN)

Connector #	Pin #	Signal name	Rod terminal to use	Connected cable
J1	1	AC_H	AI 1.5-6 BK (black)	DPYC-1.5
	2	AC_C		
	3	NC	-	-

VR-7010 TB Board (24P0133)

Connector #	Pin #	Signal name	Rod terminal to use	Connected cable
J311	1	24 V	A 1.5-10	DPYCY-1.5
	2	0 V		

Connector #	Pin #	Signal name	Rod terminal to use	Connected cable
J312	1	24 V	A 1.5-10	DPYCY-1.5
	2	0 V		

Connector #	Pin #	Signal name	Rod terminal to use	Connected cable
J313	1	24 V	A 1.5-10	DPYC-1.5
	2	0 V		
	3	NC	-	-

IF-7100 VLC Board (24P0132)

Connector #	Pin #	Signal name	Rod terminal to use	Connected cable
J1	1	24 V_IN	A 1.5-10	DPYC-1.5
	2	24 V_GND		

APPENDIX 3 ROD TERMINALS

VR-7020

Connector #	Pin #	Signal name	Rod terminal to use	Connected cable
J1	1	24 V	AI 1.5-6 BK (black)	DPYCY-1.5
	2	24 V	-	-
	3	0 V	AI 1.5-6 BK (black)	DPYCY-1.5
	4	0 V	-	-
	5	N/C	-	-
	6	TD_P	AI 0.14-8 GY (gray)	FR-FTPC-CY
	7	TD_N		
	8	RD_P		
	9	RD_N		
	10	N/C	-	-

MC-3000S, MC-CS Board (24P0114)

Connector #	Pin #	Signal name	Rod terminal to use	Connected cable
J1	1	24V_VOUT	AI 0.34-6 TQ (blue)	MC1.5-W-Lxxx
	2	24V_GND	AI 0.14-8 GY (gray)	
	3	MODBUS-A		
	4	MODBUS-B		
	5	GND	-	

Connector #	Pin #	Signal name	Rod terminal to use	Connected cable
J2	1	24V_IN	AI 1.5-6 BK (black)	DPYC-1.5
	2	24V_GND		
	3	PWR_FAIL-A	AI 0.75-6 GY (Gray)	TTYCS-4 TTYCSLA-4
	4	PWR_FAIL-COM		
	5	PWR_FAIL-B		
	6	NC	-	-

Connector #	Pin #	Signal name	Rod terminal to use	Connected cable
J4	1	TD1-A	AI 0.75-6 GY (Gray)	TTYCS-4 TTYCSLA-4
	2	TD1-B		
	3	RD1-A		
	4	RD1-B		
	5	ISOGND1		
	6	RD1-H		
	7	RD1-C		

Connector #	Pin #	Signal name	Rod terminal to use	Connected cable
J5	1	TD2-A	AI 0.75-6 GY (gray)	TTYCS-4 TTYCSLA-4
	2	TD2-B		
	3	RD2-A		
	4	RD2-B		
	5	ISOGND2		
	6	RD2-H		
	7	RD2-C		

Connector #	Pin #	Signal name	Rod terminal to use	Connected cable
J6	1	TD3-A	AI 0.75-6 GY (gray)	TTYCS-4 TTYCSLA-4
	2	TD3-B		
	3	RD3-A		
	4	RD3-B		
	5	ISOGND3		
	6	RD3-H		
	7	RD3-C		
Connector #	Pin #	Signal name	Rod terminal to use	Connected cable
J7	1	TD4-A	AI 0.75-6 GY (gray)	TTYCS-4 TTYCSLA-4
	2	TD4-B		
	3	RD4-A		
	4	RD4-B		
	5	ISOGND4		
	6	RD4-H		
	7	RD4-C		
Connector #	Pin #	Signal name	Rod terminal to use	Connected cable
J8	1	TD5-A	AI 0.75-6 GY (gray)	TTYCS-1Q TTYCSLA-1Q
	2	TD5-B		
	3	RD5-H		
	4	RD5-C		
	5	TD6-A		TTYCS-1Q TTYCSLA-1Q
	6	TD6-B		
	7	RD6-H		
	8	RD6-C		
Connector #	Pin #	Signal name	Rod terminal to use	Connected cable
J9	1	TD7-A	AI 0.75-6 GY (gray)	TTYCS-1Q TTYCSLA-1Q
	2	TD7-B		
	3	RD7-H		
	4	RD7-C		
	5	TD8-A		TTYCS-1Q TTYCSLA-1Q
	6	TD8-B		
	7	RD8-H		
	8	RD8-C		

MC-3010A MC-ANALG Board (24P0115)

Connector #	Pin #	Signal name	Rod terminal to use	Connected cable
J1	1	24V_IN	AI 0.34-6 TQ (blue)	MC1.5-W-Lxxx
	2	24V_GND		
	3	MODBUS-A	AI 0.14-8 GY (gray)	
	4	MODBUS-B		
	5	GND		
Connector #	Pin #	Signal name	Rod terminal to use	Connected cable
J2	1	24V_OUT	AI 0.34-6 TQ (blue)	MC1.5-W-Lxxx
	2	24V_GND		
	3	MODBUS-A	AI 0.14-8 GY (gray)	
	4	MODBUS-B		
	5	GND		
Connector #	Pin #	Signal name	Rod terminal to use	Connected cable
J3*	1	AN1_IN	AI 0.75-6 GY (gray)	TTYCS-1 TTYCSLA-1
	2	AN1_GND		
	3	CURR1_JP1		
	4	CURR1_JP2		
Connector #	Pin #	Signal name	Rod terminal to use	Connected cable
J4*	1	AN2_IN	AI 0.75-6 GY (gray)	TTYCS-1 TTYCSLA-1
	2	AN2_GND		
	3	CURR2_JP1		
	4	CURR2_JP2		
Connector #	Pin #	Signal name	Rod terminal to use	Connected cable
J5*	1	AN3_IN	AI 0.75-6 GY (gray)	TTYCS-1 TTYCSLA-1
	2	AN3_GND		
	3	CURR3_JP1		
	4	CURR3_JP2		

*: For pin #3 and 4, no cable is connected. However the jumper connection is necessary depending on the input specification.

MC-3020D, MC-DIN Board (24P0116)

Connector #	Pin #	Signal name	Rod terminal to use	Connected cable
J1	1	24V_IN	AI 0.34-6 TQ (blue)	MC1.5-W-Lxxx
	2	24V_GND		
	3	MODBUS-A	AI 0.14-8 GY (gray)	
	4	MODBUS-B		
	5	GND		
Connector #	Pin #	Signal name	Rod terminal to use	Connected cable
J2	1	24V_OUT	AI 0.34-6 TQ (blue)	MC1.5-W-Lxxx
	2	24V_GND		
	3	MODBUS-A	AI 0.14-8 GY (gray)	
	4	MODBUS-B		
	5	GND		
Connector #	Pin #	Signal name	Rod terminal to use	Connected cable
J3*	1	DV12V_OUT1	AI 1-6 RD (red)	MPYC-12
	2	DIGI_IN1		
	3	DIGI_RTN1		
	4	GND		
	5	DC12V_OUT2		
	6	DIGI_IN2		
	7	DIGI_RTN2		
	8	GND		
Connector #	Pin #	Signal name	Rod terminal to use	Connected cable
J4*	1	DV12V_OUT3	AI 1-6 RD (red)	MPYC-12
	2	DIGI_IN3		
	3	DIGI_RTN3		
	4	GND		
	5	DC12V_OUT4		
	6	DIGI_IN4		
	7	DIGI_RTN4		
	8	GND		
Connector #	Pin #	Signal name	Rod terminal to use	Connected cable
J5*	1	DV12V_OUT5	AI 1-6 RD (red)	MPYC-12
	2	DIGI_IN5		
	3	DIGI_RTN5		
	4	GND		
	5	DC12V_OUT6		
	6	DIGI_IN6		
	7	DIGI_RTN6		
	8	GND		

*: Pin #1 and 5: no cable connection. However the jumper connection is necessary between #1 and 2 and #5 and 6 depending on the input specification.

APPENDIX 3 ROD TERMINALS

Connector #	Pin #	Signal name	Rod terminal to use	Connected cable
J6*	1	DV12V_OUT7	AI 1-6 RD (red)	MPYC-12
	2	DIGI_IN7		
	3	DIGI_RTN7		
	4	GND		
	5	DC12V_OUT8		
	6	DIGI_IN8		
	7	DIGI_RTN8		
	8	GND		

*: Pin #1 and 5: no cable connection. However the jumper connection is necessary between #1 and 2 and #5 and 6 depending on the input specification.

APPENDIX 4 DIGITAL INTERFACE

Digital Interface

ACN - Alert command

\$--ACN,hhmmss.ss,aaa,x.x,x.x,c,a*hh<CR><LF>

1 2 3 4 5 6

1. Time (UTC)
2. Manufacturer mnemonic code (3 digits)
3. Alert Identifier (0 - 9999999)
4. Alert Instance (1 - 999999,nul)
5. Alert command (A,Q,O,S)
 - A=acknowledge
 - Q=request/repeat information
 - O*=responsibility transfer
 - S=silence
 - *: Not supported.
6. Sentence status flag (C) (fixed)

ALA - Set detail alarm condition

\$--ALA, hhmmss.ss, aa, aa, xx, xxx, A, A, c—c *hh<CR><LF>

1 2 3 4 5 6 7 8

1. Event time
Event time of alarm condition change includeing acknowledgement state change. If this is not available, this should be a null field.
2. System Indicator of original alarm source
Indicator characters as system of alarm source. This field is two fixed characters, see IEC61162-1 Ed.4.
3. Sub system equipment indicator of original alarm source
Indicator characters as sub-system of alarm source. This field is two fixed characters, see IEC61162-1 Ed.4. For group alarms or if no sub-system can be identified, this should be a null field.
4. Instance number of equipment/unit/item
Instance number identifying the equipment, unit or item. This field is two fixed numeric characters.
5. Type of alarm
Type of alarm. This field is three fixed numeric characters as defined in IEC61162-1 Ed.4. Codes 900 to 999 are user definable.
6. Alarm condition
This field is a single character specified by the following.
 - N = normal state;
 - H = alarm state (threshold exceeded);
 - J = alarm state (extreme threshold exceeded);
 - L = alarm state (low threshold exceeded, i.e. not reached);
 - K = aram state (extreme low threshold exceeded, i.e. not reached);
 - X = other.
7. Alarm's acknowledged state
This field is a single character specified by the following:
 - A = acknowledged;
 - V = not acknowledged;
 - B = broadcast (acknowledged not applicable);
 - H = habour mode;
 - O = override.
8. Alarm's description text
Additional and optional descriptive text/alarm detail condition tag. Maximum number of characters will be limited by maximum sentence length and length of other fields.

APPENDIX 4 DIGITAL INTERFACE

ALC - Cyclic alert list

\$--ALC,xx,xx,xx,x,x,aaa,x,x,x,x,x,""" *hh<CR><LF>
1 2 3 4 5 6 7 8 9

1. Total number of sentences this message (01 to 99)
2. Sentence number (01 to 99)
3. Sequential message identifier (00 to 99)
4. Number of alert entries (0 to 3)
5. Manufacturer mnemonic code (FEC, null)
6. Alert identifier (999 or 10001 to 10999)
7. Alert instance (null)
8. Revision counter (1 to 99)
9. Additional alert entries (same as 5 and 8)

ALF - Alert sentence

\$--ALF,x,x,x,hhmmss.ss,a,a,a,aaa,x,x,x,x,x,x,c--c*hh<CR><LF>
1 2 3 4 5 6 7 8 9 10 11 12 13

1. Total number of ALF sentences for this message (1, 2)
2. Sentence number (1, 2)
3. Sequential message identifier (0 to 9)
4. Time of last change (hh=00 to 23, mm=00 to 59, ss.ss=00.00 to 60.99), null
5. Alert category (A=Alert category A, B=Alert category B, C=Alert category C), null
6. Alert priority (A=Alarm, W=Warning, C=Caution), null when #2 is 2.
7. Alert state (V=Not ACKed, S=Silence, A=ACKed, O*/U=Resolved, Not ACKed, N=Normal state), null when #2 is 2.
*: Not supported.
8. Manufacturer mnemonic code (FEC, null)
9. Alert identifier (999 or 10001 to 10999)
10. Alert instance (null)
11. Revision counter (1 to 99)
12. Escalation counter (0 to 2)
13. Alert text (max. 16 characters)

ALR - Set alarm state

\$--ALR,hhmmss.ss,xxx,A,A,c--c*hh<CR><LF>
1 2 3 4 5

1. Time of alarm condition change, UTC (000000.00 to 240001.00)
2. Unique alarm number (identifier) at alarm source (000 to 999)
3. Alarm condition (A=threshold exceeded, V=not exceeded)
4. Alarm's acknowledge state (A=acknowledged, V=not acknowledged)
5. Alarm's description text (alphanumeric)

DOR - Door status indication

\$--DOR,a,hhmmss.ss,aa,cc,xxx,xxx,a,a,c--c*hh<CR><LF>
 1 2 3 4 5 6 7 8 9

1. Message type
 S=Status for section: the number of faulty and/or open doors reported in the division specified in field 4 and 5. The section may be a whole section (one or both of the division indicator fields are null) or a sub-section. The status S is normally transmitted at regular intervals.
 E = Status for single door. (E may be used to indicate an event).
 F = Fault in system: Division indicator fields defines the section when provided.
2. Event time
 Time when this status/message was valid.
3. Type of door monitoring system
 The field is two characters, see table below.
4. First division indicator
 First division indicator where door is located.
5. Second division indicator
 Second division indicator where door is located.
6. Door number or door open count
 This field is three fixed numeric characters. When the message type field is E this field identifies the door. When message type fields is S this field contains the number of doors that are open or faulty. When the message type field is F this field is null.
7. Door status
 When the message type is S or F this field should be a null field. When the message type field is E. this field is specified by the following:
 O = Open C = Close F = Free status (for watertight door) X = Fault (door status unknown)
8. Water tight door switch setting
 This field includes a single character specified by the following:
 O = Harbour mode (allowed open) C = Sea mode (ordered closed)
9. Message's description text
 Descriptive text/door tag. If a door allocation identifier is string type, it is possible to use this field instead of the above door allocation fields. The maximum number of characters will be limited by the maximum sentence length and the length of other fields.

Type of door monitoring system		First division indicator	Second division indicator
ID	System category		
WT	Watertight door	Number of watertight bulk-head/frame number	Deck number
WS	Semi-watertight door (splash-tight)		
FD	Fire door	Number / letter of zone. This can also be identifier for control and monitoring main system.	Deck number or control system loop number or other control system division indicator as is appropriate for system
HD	Hull (shell) door	Door indication number / frame number	Deck number
OT	Other	As above	As above

DPT - Depth

\$--DPT,x.x,x.x,x.x*hh<CR><LF>
 1 2 3

1. Water depth relative to the transducer, in meters (0.00 to 99999.99)
2. Offset from transducer, in meters (-99.99 to 99.99)
3. Minimum range scale in use (no use)

APPENDIX 4 DIGITAL INTERFACE

DTM - Datum reference

\$--DTM,ccc,a,x.x,a,x.x,a,x.x,ccc*hh<CR><LF>
1 2 3 4 5 6 7 8

1. Local datum (W84=WGS84 W72=WGS72 S85=SGS85, P90=PE90
User defined=999, IHO datum code)
2. Local datum subdivision code (null or one character)
3. Lat offset, min (-59.99999 to 59.59999)
4. N/S
5. Lon offset, min (no use)
6. E/W
7. Altitude offset, meters (no use)
8. Reference datum (W84=WGS84 W72=WGS72 S85=SGS85, P90=PE90)

ETL - Engine telegraph operation status

\$--ETL,hhmmss.ss,a,xx,xx,a,x*hh<CR><LF>
1 2 3 4 5 6

1. Event time (UTC)
2. Message type (O=Order A=Answerback)
3. Position indicator of engine telegraph
 - 00=Stop engine
 - 01=[AH] Dead Slow
 - 02=[AH] Slow
 - 03=[AH] Half
 - 04=Full
 - 05=[AH] Nav. Full
 - 11=[AS] Dead Slow
 - 12=[AS] Slow
 - 13=[AS] Half
 - 14=[AS] FullI
 - 15=[AS] Crash Astern
4. Position indication of sub telegraph (000 to 100)
5. Operating location indicator (B=Bridge P=Port wing S=Starboard wing C=Engine control room
E=Engine side/local W=Wing)
6. Number of engine or propeller shaft (000 to 100)

FIR - Fire detection

\$--FIR, A₁, hhmmss.ss, aa₃, cc₄, xxx₅, xxx₆, a₇, a₈, c--c₉ *hh<CR><LF>

1. Message type
 - S: Status for section: the number of faulty and activated condition reported as number in field 6. The section may be a whole section (one or both of the division indicator fields are null) or a sub-section. The status S is normally transmitted at regular intervals. Examples of use are given in Annex E.
 - E: Status for each detector. (E may be used to indicate an event.)
 - F: Fault in system: Division indicator fields defines the section when provided.
 - D: Disabled: Detector is manually or automatically disabled from giving fire alarms.
2. Event time
 - Time of condition change or acknowledgement. This may be a null field.
3. Type of fire detection system
 - The field is two fixed characters, see table below.
4. First division indicator
 - First division indicator where detector is located. This field is two characters, see table below.
5. Second division indecator
 - Second division indicator where the detector is located. This field is three numeric characters, see table below.
6. Fire ditector number or activation detection count
 - This field is three fixed numeric characters. When the message type field is E, this field identifies the detector. When message type field is S this field contains the number of detectors activated. When the message type field is F or D this field is null.
7. Condition
 - When the message type field is S this field should be a null field. When the message type field is E, F or D this field includes a single character specified by the following:
 - A = Activation
 - V = Non-activation
 - X = Fault (state unknown)
8. Alarm's acknowledgement state
 - When the message field type is E or F this field includes a single character specified by the following:
 - A = acknowledged
 - V = not acknowledged
 - When the message field type is S or D this shold be a null field.
9. Message description text
 - Descriptive text/sensor location tag. If a sensor location identifier is string type, it is possible to use this field instead of above sensor allocation fields. Maximum number of characters will be limited by the maximum sentence length and the length of other fields.

Type of door monitoring system		First division indicator	Second division indicator
ID	System category		
FD	Generic fire detector, can be any of ones below.	Number / letter of zone. This can also be a control and monitoring system main unit identifier, for example fire central number / letter.	Loop number. This can be also be another control and monitoring sub-system identifier, for example sub-central.
FH	Heat type detector		
FS	Smoke type detector		
FD	Smoke and heat detector		
FM	Manual call point		
GD	Any gas detector	As above	As above
GO	Oxygen gas detector		
GS	Hydrogen Sulphide gas detector		
GH	Hydro-carbon gas detector		
SF	Sprinkler flow switch	As above	As above
SV	Sprinkler manual valve release		
CO	CO ₂ manual release	As above	As above
OT	Other	As above	As above
Note: For units controlled from the fire system (typically all FD, FH, FS, FD and FM), the normal division indicators should be fire zone and loop number.			

APPENDIX 4 DIGITAL INTERFACE

GEN - Generic status information

\$--GEN,hhhh,hhmmss.ss,hhhh,.....,hhhh *hh<CR><LF>
1 2 3 4 5

1. Index of first packed binary field in sentence
Index of first group in GEN sentence. Address is represented in hexadecimal format in the HEX range 0000 through FFFF. The 16-bit address is formatted as fixed 4-character HEX field.
2. Time stamp
This may be a null field.
3. Packed binary field
The packed binary field is represented as a 6-bit value.
The 16-bit value is formatted as fixed 4-character HEX field. This may be a null field.
4. Variable number of packed binary field
Optional repeated packed binary field. Each repeat increases the index by one.
Up to seven repetitions yielding a total of 128 bits per sentence is possible.
5. Packed binary field
The packed binary field is represented as a 6-bit value.
The 16-bit value is formatted as fixed 4-character HEX field. This may be a null field.

GGA - Global positioning system fix data

\$--GGA,hhmmss.ss,lll.lll,a,yyyyy.yyy,a,x,xx,x.x,x.x,M,x.x,M,x.x,xxxx*hh<CR><LF>
1 2 3 4 5 6 7 8 9 10 11 12 13 14

1. UTC of position (no use)
2. Latitude (0.00000 to 9000.00000)
3. N/S
4. Longitude (0.00000 to 18000.00000)
5. E/W
6. GPS quality indicator (1 to 5, 8)
7. Number of satellite in use (00 to 99)
8. Horizontal dilution of precision (0.00 to 999.99)
9. Antenna altitude above/below mean sea level (-999.99 to 9999.99)
10. Units of antenna altitude, m
11. Geoidal separation (-999.99 to 9999.99)
12. Units of geoidal separation, m
13. Age of differential GPS data (0 to 99)
14. Differential reference station ID (0000 to 1023)

GLL - Geographic position, latitude/longitude

\$--GLL,lll.lll,a,yyyyy.yyy,a,hhmmss.ss,a,x*hh<CR><LF>
1 2 3 4 5 6 7

1. Latitude (0.00000 to 9000.00000)
2. N/S
3. Longitude (0.00000 to 18000.00000)
4. E/W
5. UTC of position (no use)
6. Status (A=data valid V=data invalid)
7. Mode indicator (A=Autonomous D=Differential S=Simulator)

GNS - GNSS fix data

```
$--GNS,hhmmss.ss,lll.lll,a,llll.lll,a,c--c,xx,x.x,x.x,x.x,x.x,x.x,x.x,a*hh<CR><LF>
      1      2 3 4 5 6 7 8 9 10 11 12 13
```

1. UTC of position (no use)
2. Latitude (0.00000 to 9000.00000)
3. N/S
4. Longitude (0.00000 to 18000.00000)
5. E/W
6. Mode indicator
N=No fix A=Autonomous D=Differential P=Precise R=Real Time Kinematic
F=Float RTK E=Estimated Mode M=Manual Input Mode S=Simulator Mode
7. Total number of satellites in use (00 to 99)
8. HDOP (0.0 to 999.99)
9. Antenna altitude, meters (-999.99 to 9999.99)
10. Geoidal separation (-999.99 to 9999.99)
11. Age of differential data (0 to 999)
12. Differential reference station ID (0000 to 1023)
13. Navigational status indicator

HBT - Heartbeat supervision sentence

```
$--HBT,x.x,A,x*hh<CR><LF>
      1 2 3
```

1. Configured repeat interval (00.0 to 99.9(s))
2. Equipment status, A=Normal (fixed)
3. Sequential sequence identifier (0 to 9)

HDG - Heading Magnetic

```
$--HDG,x.x,x.x,a,x.x,a*hh<CR><LF>
      1 2 3 4 5
```

1. Magnetic sensor heading, degrees (0.00 to 360.00)
2. Magnetic deviation, degrees (0.0 to 180.00)
3. E/W
4. Magnetic variation, degrees (0.0 to 180.00)
5. E/W

HDT - Heading, true

```
$--HDT,xxx.x,T*hh<CR><LF>
      1 2
```

1. Heading, degrees (0.00 to 360.00)
2. True (T)

APPENDIX 4 DIGITAL INTERFACE

HRM - Heel angle, roll period and roll amplitude measurement device

\$--HRM,x.x,x.x,x.x,x.x,A,x.x,x.x,hmmss.ss,xx,xx,*hh<CR><LF>
1 2 3 4 5 6 7 8 9 10

1. Actual heel angle, degrees (see Note 1)
2. Roll period, seconds (see Note 2)
3. Roll amplitude, port side, degrees (see Note 3)
4. Roll amplitude, starboard side, degrees (see Note 4)
5. Status (see Note 5)
6. Roll peak hold value, port side, degrees (see Note 6)
7. Roll peak hold value, starboard side, degrees (see Note 7)
8. Peak hold value reset time (see Note 8)
9. Peak hold value reset day, 01 to 31 (see Note 9)
10. Peak hold value reset month, 01 to 12 (see Note 10)

Note 1: Actual heel angle, momentary angle of roll referenced to a levelled ship to port or starboard side, (positive value starboard, negative value port)

Note 2: Roll period, time between successive maximum values of heel angle to port over starboard and back to port (or the other way round)

Note 3: Roll amplitude of port side as positive value, maximum value of heel angle to port side of the latest motion

Note 4: Roll amplitude of starboard side, maximum value of heel angle to starboard side of the latest motion

Note 5: Status, A=data valid, V=data invalid

Note 6: Roll peak hold value of port side, maximum value of heel angle to port side of the motions measured from the last reset with a minimum resolution of 1 degree. This shall be a null field when data is not available

Note 7: Roll peak hold value of starboard side, maximum value of heel angle to starboard side of the motions measured from the last reset with a minimum resolution of 1 degree. This shall be a null field when data is not available

Note 8: Peak hold value reset time, time when the peak hold values are reset, UTC hour, minute and second. Decimal point and fractions of the seconds shall not be used. This shall be a null field when data is not available

Note 9: Peak hold value reset day, day when the peak hold values are reset, UTC day. This shall be a null field when data is not available

Note 10: Peak hold value reset month, month when the peak hold values are reset, UTC month. This shall be a null field when data is not available

HSS - Hull stress surveillance systems

\$--HSS,c--c,x.x,A*hh<CR><LF>
1 2 3

1. Measurement point ID
2. Measurement value
3. Data status
A = data valid
V = data invalid

HTC - Heading/Track control command

\$--HTC,A,x.x,a,a,x.x,x.x,x.x,x.x,x.x,x.x,x.x,a,a*hh<CR><LF>
 1 2 3 4 5 6 7 8 9 10 11 12 13 14

1. Override, A = in use, V = not in use
2. Commanded rudder angle, degrees
3. Commanded rudder direction, L/R=Port/starboard
4. Selected steering mode
5. Turn mode R=Radius controlled
 T=Turn rate controlled
 N=Turn is not controlled
6. Commanded rudder limit, degrees (unsigned)
7. Commanded off-heading limit, degrees (unsigned)
8. Commanded radius of turn for heading changes, n.miles
9. Commanded rate of turn to heading changes, deg/min
10. Commanded heading-to-steer, degrees
11. Commanded off-track limit, n.miles (unsigned)
12. Commanded track, degrees
13. Heading reference in use, T/M
14. Sentence status

HTD - Heading/Track control data

\$--HTD,A,x.x,a,a,x.x,x.x,x.x,x.x,x.x,x.x,x.x,x.x,a,A,A,x.x*hh<CR><LF>
 1 2 3 4 5 6 7 8 9 10 11 12 13 14 15 16 17

1. Override, A=In use, V=Not in use
2. Commanded rudder angle, degrees
3. Commanded rudder direction, L/R=Port/starboard
4. Selected steering mode
5. Turn mode R=Radius controlled
 T=Turn rate controlled
 N=Turn is not controlled
6. Commanded rudder limit, degrees (unsigned)
7. Commanded off-heading limit, degrees (unsigned)
8. Commanded radius of turn for heading changes, n.miles
9. Commanded rate of turn to heading changes, deg/min
10. Commanded heading-to-steer, degrees
11. Commanded off-track limit, n.miles (unsigned)
12. Commanded track, degrees
13. Heading reference in use, T/M
14. Rudder status (A=Within limits, V=Limit reached or exceeded)
15. Off-heading status (A=Within limits, V=Limit reached or exceeded)
16. Off-track status (A=Within limits, V=Limit reached or exceeded)
17. Vessel heading, degrees

MTW - Water temperature

\$--MTW, x.x, C*hh<CR><LF>
 1

1. Water temperature, degrees C (-9.999 to 99.999)

MWV - Wind speed and angle

\$--MWV,x.x,a,x.x,a,A*hh<CR><LF>
 1 2 3 4 5

1. Wind angle, 0° to 359°
2. Reference, R = relative, T = true
3. Wind speed
4. Wind speed units, K = km/h M =m/s N = knots
5. Status, A = data valid V = data invalid

APPENDIX 4 DIGITAL INTERFACE

NSR - Navigation status report

\$--NSR, a, A, a, A, a, A, a, A, a, A, a, a, A *hh<CR><LF>
1 2 3 4 5 6 7 8 9 10 11 12 13

1. Integrity of heading (see NOTE 1)
2. Plausibility of heading (see NOTE 2)
3. Integrity of position (see NOTE 1)
4. Plausibility of position (see NOTE 2)
5. Integrity of STW (see NOTE 1)
6. Plausibility of STW (NOTE 2)
7. Integrity of SOG and COG (see NOTE 1)
8. Plausibility of SOG and COG (see NOTE 2)
9. Integrity of depth (see NOTE 1)
10. Plausibility of depth (see NOTE 2)
11. Mode of STW (see NOTE 3)
12. Integrity of time (see NOTE 1)
13. Plausibility of time (see NOTE 2)

NOTE 1 Integrity status:

P = Passed, Integrity verification passed
F = Failed, integrity verification not passed
D = Doubtful, integrity verification not possible
N = Not available, reporting device does not support integrity check

NOTE 2 Plausibility status:

A = Yes (Plausible)
V = No (Not plausible)
N = Not available, reporting device does not support plausibility check

NOTE 3 Mode of STW

W = Measured water reference
E = Estimated/calculated from non-water referenced sources
M = Manual input
N = Not available

PRC - Propulsion remote control status

\$--PRC,x,x,A,x,x,a,x,x,a,a,x*hh<CR><LF>
1 2 3 4 5 6 7 8

1. Lever demand position (-100 to 100, 0=Stop)
2. Lever demand status (A=Data valid V=Data invalid)
3. RPM demand value (-9999.9 to 9999.9)
4. RPM mode indicator (P=Per cent R=Revolutions per min.)
5. Pitch demand value (-999.9 to 999.9)
6. Pitch mode indicator (P=Per cent D=Degrees V=Data invalid)
7. Operating location indicator (B=Bridge P=Port wing S=Starboard wing
C=Engine control room E=Engine side/local W=Wing)
8. Number of engine or propeller shaft (00 to 99)

RMC - Recommended minimum specific GPS/TRANSMIT data

```
$--RMC,hhmmss.ss,A,llll.ll,a,yyyy.yy,a,x.x,x.x,ddmmyy,x.x,a,a*hh<CR><LF>
      1  2 3 4  5  6 7 8  9  10 11 12 13
```

1. UTC of position fix (000000 to 235959)
2. Status (A=Data valid, V=Navigation receiver warning)
3. Latitude (0.0000 to 9000.0000)
4. N/S
5. Longitude (0.0000 to 18000.0000)
6. E/W
7. Speed over ground, knots (0.0 to 9999.9)
8. Course over ground, degrees true (0.0 to 359.0)
9. Date (010100 to 311299)
10. Magnetic variation, degrees E/W (0.0 - 180.0/NULL)
11. E/W
12. Mode indicator (A=Autonomous D=Differential mode E=Estimated (dead reckoning) mode)
M=Manual input mode S=Simulator N=Data not valid)
13. Navigational status indication

ROR - Rudder order status

```
$--ROR, x.x, A, x.x, A, a*hh<CR><LF>
      1  2  3  4  5
```

1. Starboard (or single) rudder order (-90 to 90.0)
2. Status (A=Valid V=Invalid)
3. Port rudder order (-90.0 to 90.0)
4. Status (A=Valid V=Invalid)
5. Command source location (B=Bridge P=Port wing S=Starboard wing
C=Engine control room E=Engine side/local W=Wing)

ROT - Rate of turn

```
$--ROT,x.x,A*hh<CR><LF>
      1  2
```

1. Rate of turn, deg/min, "-"=bow turns to port (-9999.9 to 9999.9)
2. Status: A=Data valid, V=Data invalid

RPM - Revolutions

```
$--RPM, a, x, x.x, x.x, A*hh<CR><LF>
      1  2  3  4  5
```

1. Source (S=Shaft E=Engine)
2. Engine or shaft number (00 to 99)
3. Speed, revolutions/min (-9999.99 to 9999.99)
4. Propeller pitch (-100.0 to 100.0)
5. Status (A=Data invalid V=Data valid)

RSA - Rudder sensor angle

```
$--RSA,x.x,A,x.x,A*hh<CR><LF>
      1  2
```

1. Starboard (or single) rudder sensor status
Status A = valid,
V = data invalid
2. Port rudder sensor
Status A = valid,
V = data invalid

APPENDIX 4 DIGITAL INTERFACE

RTE - Routes

\$--RTE,x,x,x,x,a,c--c,c--c,.....,c--c*hh <CR><LF>

1 2 3 4 5 6 7

1. Total number of messages being transmitted (1 to n, or null)
2. Sentence number (1 to n, or null)
3. Message mode (C=Complete route W=Working route, first listed)
4. Route identifier (alphabet or null)
5. Waypoint identifier (alphabet or null)
6. Additional waypoint indentifiers
7. Waypoint "n" identifier (alphabet or null)

THS - True heading & status

\$--THS,xxx.x,a*hh<CR><LF>

1 2

1. Heading, degrees True (0.00 to 360.00)
2. Mode indicator (A=Autonomous E=Estimated M=Manual input
S=Simulator V=Data not valid)

TRC - Thruster control data

\$--TRC,x,x,x,a,x,x,a,x,x,a,a*hh<CR><LF>

1 2 3 4 5 6 7 8

1. Number of thruster, bow or stern
Odd = Bow thruster Even = Stern thrusters
2. RPM demand value
"- " port
3. RPM mode indicator
P = Per cent (%): 0 - 100 % from zero to maximum rpm
R = Revolutions per min V = data invalid
This should not be a null field.
4. Pitch demand value
"- " port
5. Pitch mode indicator
P = Per cent (%) D = Degree (°) V = Data invalid
6. Azimuth demand (000.0 to 359.9)
Direction of thrust in degrees (0° - 360°). This may be a null field.
7. Operating location indicator
B = Bridge P = Port wing S = Starboard wing
C = Engine control room E = Engine side/local W = Wing
This should not be a null field.
8. Sentence status flag
R = Sentence is status report of current settings (used for a reply to a query).
C = Sentence is a configuration command to change settings. A sentence without
"C" is not a command.

TRD - Thruster response data

\$--TRD, x, x.x, A, x.x, A, x.x*hh<CR><LF>
 1 2 3 4 5 6

1. Number of thrusters
 Odd=Bow thruster Even=Stern thrusters
2. RPM response
3. RPM mode indicator
 P = P = Per cent (%): 0 - 100 % from zero to maximum rpm
 R = Revolutions per minute (RPM)
 V = data invalid
 This should not be a null field.
4. Pitch response value
 "-" port
5. Pitch mode indicator
 P = P = Per cent (%) D = Degrees V = data invalid
 This should not be a null field.
6. Azimuth response
 Direction of thrust in degrees (0° - 360°). This may be a null field.

TTM - Tracked target message

\$--TTM,xx,x.x,x.x,a,x.x,x.x,a,x.x,x.x,a,c--c,a,a,hhmmss.ss,a*hh<CR><LF>
 1 2 3 4 5 6 7 8 9 10 11 12 13 14 15

1. Target number (00 to 99)
2. Target distance from own ship (0.000 to 999.9)
3. Bearing from own ship,degrees (0.0 to 359.9)
4. True or Relative
5. Target speed (0.00 to 99.9, 100.0 to 999.9)
6. Target course, degrees (0.0 to 359.9)
7. True or Relative
8. Distance of closet point of approach (0.000 to 999.9)
9. Time to CPA, min., "-" increasing (-6000 to 6000)
10. Speed/distance units, K=Km, km/h N=knots, km S=sm, mph)
11. Target name (c--c)
12. Target status (L=Lost Q=Acquiring T=Tracking)
13. Reference target (R, null otherwise)
14. Time of data (hhmmss.ss)
15. Type of acquisition (A=Automatic M=Manual R=Reported)

VBW - Dual ground/water speed

\$--VBW,x.x,x.x,x.x,x.x,x.x,x.x,x.x,x.x,x.x*hh<CR><LF>
 1 2 3 4 5 6 7 8 9 10

1. Longitudinal water speed, knots (-9999.99 to 9999.99)
2. Transverse water speed, knots (-9999.99 to 9999.99)
3. Status: water speed, A=Data valid V=Data invalid
4. Longitudinal ground speed, knots (-9999.99 to 9999.99)
5. Transverse ground speed, knots (-9999.99 to 9999.99)
6. Status: ground speed, A=Data valid V=Data invalid
7. Stern transverse water speed, knots (-9999.99 to 9999.99)
8. Status: stern water speed, A=Data valid V=Data invalid
9. Stern transverse ground speed, knots (-9999.99 to 9999.99)
10. Status: stern ground speed, A=Data valid V=Data invalid

APPENDIX 4 DIGITAL INTERFACE

VDM - UAIS VHF data-link message

!--VDM,x,x,x,x,s--s,x*hh<CR><LF>
1 2 3 4 5 6

1. Total number of sentences needed to transfer the message (1 to 9)
2. Sentence number (1 to 9)
3. Sequential message identifier (0 to 9, null)
4. AIS channel (A or B)
5. Encapsulated ITU-R M.1371 radio message (1 to 63 bytes)
6. Number of fill-bits (0 to 5)

VDO - UAIS VHF data-link own vessel report

!--VDO,x,x,x,x,s--s,x*hh<CR><LF>
1 2 3 4 5 6

1. Total number of sentences needed to transfer the message (1 to 9)
2. Sentence number (1 to 9)
3. Sequential message identifier (0 to 9, null)
4. AIS channel Number (A or B)
5. Encapsulated ITU-R M.1371 radio message (1 to 63 bytes)
6. Number of fill-bits (0 to 5)

VDR - Set and drift

\$--VDR,x.x,T,x.x,M,x.x,N*hh <CR><LF>
1 2 3 4 5 6

1. Direction, degrees (0.0 to 360.0)
2. T=True (fixed)
3. Direction, degrees (0.0 to 360.0)
4. M=Magnetic (fixed)
5. Current speed (0 to 99.99)
6. N=Knots (fixed)

VHW - Water speed and headings

\$--VHW,x.x,T,x.x,M,x.x,N,x.x,K*hh <CR><LF>
1 2 3 4

1. Heading, degrees true
2. Heading, degrees magnetic
3. Speed, knots
4. Speed, km/h

VLW - Dual ground/water distance

\$--VLW,x.x,N,x.x,N,x.x,N,x.x,N*hh<CR><LF>
1 2 3 4 5 6 7 8

1. Total cumulative water distance (0.0 to 999999.999)
2. N=Nautical miles
3. Water distance since reset (0.000 to 999999.999)
4. N=Nautical miles
5. Total cumulative ground distance (no use)
6. N=Nautical miles (no use)
7. Ground distance since reset (no use)
8. N=Nautical miles (no use)

VTG - Course over ground and ground speed

\$--VTG,x.x,T,x.x,M,x.x,N,x.x,K,a*hh <CR><LF>
 1 2 3 4 5 6 7 8 9

1. Course over ground, degrees (0.0 to 359.9)
2. T=True (fixed)
3. Course over ground, degrees (0.0 to 359.9)
4. M=Magnetic (fixed)
5. Speed over ground, knots (0.00 to 9999.9)
6. N=Knots (fixed)
7. Speed over ground (0.00 to 9999.9)
8. K=km/h (fixed)
9. Mode indicator (A=Autonomous, D=Differential E=Estimated (dead reckoning)
 M=Manual input S=Simulator N=Data not valid)

WAT - Water level detection

\$--WAT, a, hhmmss.ss, aa, xx, xx, xxx, a, a, c--c*hh<CR><LF>
 1 2 3 4 5 6 7 8 9

1. Message type
 - S: Status for section: Number of faulty and activated condition reported as number in field 4 and 5. The section may be a whole section (one or both of the location indicator fields are null) or a sub-section. The status S is normally transmitted at regular intervals.
 - E: Status for each water level detector. (E may be used to indicate an event.)
 - F: Fault in system: location indicator fields define the sections when provided.
2. Time stamp
 - Time when this status/message was valid.
3. Type of water alarm
 - Indicator characters showing system detecting water level. The field is two characters.
 - WL = Water level detection system;
 - BI = High water level by bilge system;
 - HD = Water leakage at hull (shell) door;
 - OT = others.
4. First location indicator
 - First location indicator characters showing detection location. This field is two characters. The contents of this field is not defined by this standard, but the two location fields should uniquely define the source for the alarm.
5. Second location indicator
 - Second location indicator characters showing detection location. This field is two characters. The contents of this field is not defined by this standard, but the two location fields should uniquely define the source for the alarm.
6. Detection point number or detection point count
 - This field is three fixed numeric characters. When the message type field is E this field identifies the high-water-level detection point. When the message type field is S this field contains the number of the water leakage detection points. When the message type field is F this field is a null field.
7. Alarm condition
 - This field is a single character specified by the following:
 - N = normal state
 - H = alarm state (threshold exceeded)
 - J = alarm state (extreme threshold exceeded)
 - L = alarm state (Low threshold exceeded i.e. not reached)
 - K = alarm state (extreme low threshold exceeded i.e. not reached)
 - X = Fault (state unknown)
8. Override setting
 - O = Override mode (water allowed in space);
 - N = Normal mode (water not allowed in space);
9. Message description text
 - Descriptive text/level detector tag. If a level detector identifier type, it is possible to use this field instead of above level detector fields. Maximum number of characters will be limited by maximum sentence length and length of other fields.

APPENDIX 4 DIGITAL INTERFACE

WPL - Waypoint location

\$--WPL, llll.ll, a, yyyyy.yy, a, c--c*hh<CR><LF>
 1 2 3 4 5

1. Waypoint latitude (0.000000 to 9000.00000)
2. N/S
3. Waypoint longitude (0.00000 to 18000.00000)
4. E/W
5. Waypoint identifier (No use)

XDR - Transducer measurements

\$--XDR, a, x.x, a, c--c,a, x.x, a, c--c*hh<CR><LF>
 1 2 3 4 5 6

1. Transducer type, transducer No. 1 (see Note 2)
2. Measurement data, transducer No. 1
3. Units of measure, transducer No. 1 (see Note 2)
4. Transducer No. 1 ID
5. Data, variable number of transducers
6. Transducer "n" (see Note 1)

Note 1: Sets of the four fields "type-data-units-ID" are allowed for an undefined number of transducers. Up to "n" transducers may be included within the limits of allowed sentence length; null fields are not required except where portions of the "type-data-units-ID" combination are not available.

Note 2: Allowed transducer types and their units of measure are:

Transducer	Type field	Units	Comments
Temperature	C	C = degrees Celsius	
Angular displacement	A	D = degrees	"-" = anticlockwise
Absolute humidity	B	K = kg/m ³	Kilograms per cubic metre
Linear displacement	D	M = metres	"-" = compression
Frequency	F	H = Hertz	ppt = parts per thousand
Salinity	L	S = ppt	"-" = compression
Force	N	N = newtons	"-" = vacuum
Pressure	P	P = pascals	
Flow rate	R	l = litres/s	
Tachometer	T	R = revolutions/min	
Humidity	H	P = per cent	
Volume	V	M = cubic metres	
Voltage	U	V = volts	1 = ON, CLOSED; 0 = OFF,
Current	I	A = amperes	OPENx.x = variable data
Switch or valve	S	None (null)	
Generic	G	None (null)	

ZDA - Time and date

\$--ZDA, hhmmss.ss, xx, xx, xxxx, xx, xx*hh<CR><LF>
 1 2 3 4 5 6

1. UTC
2. Day, 01 to 31 (UTC)
3. Month, 01 to 12 (UTC)
4. Year (UTC)
5. Local zone hours (00 h to ±13h)
6. Local zone minutes (00 to +59)

Serial Interface: IEC61162-1

- Data Collecting Unit, input

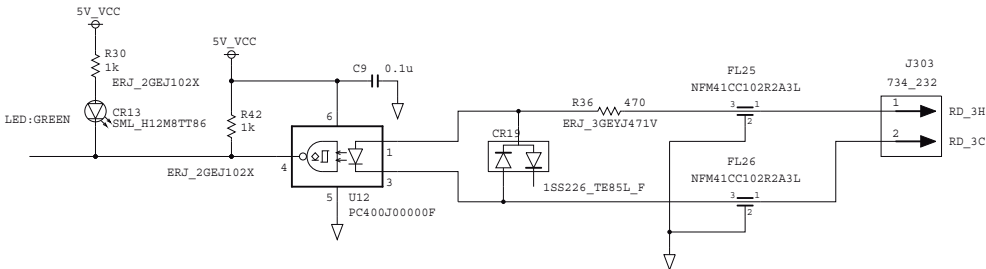

- Data Collecting Unit, output

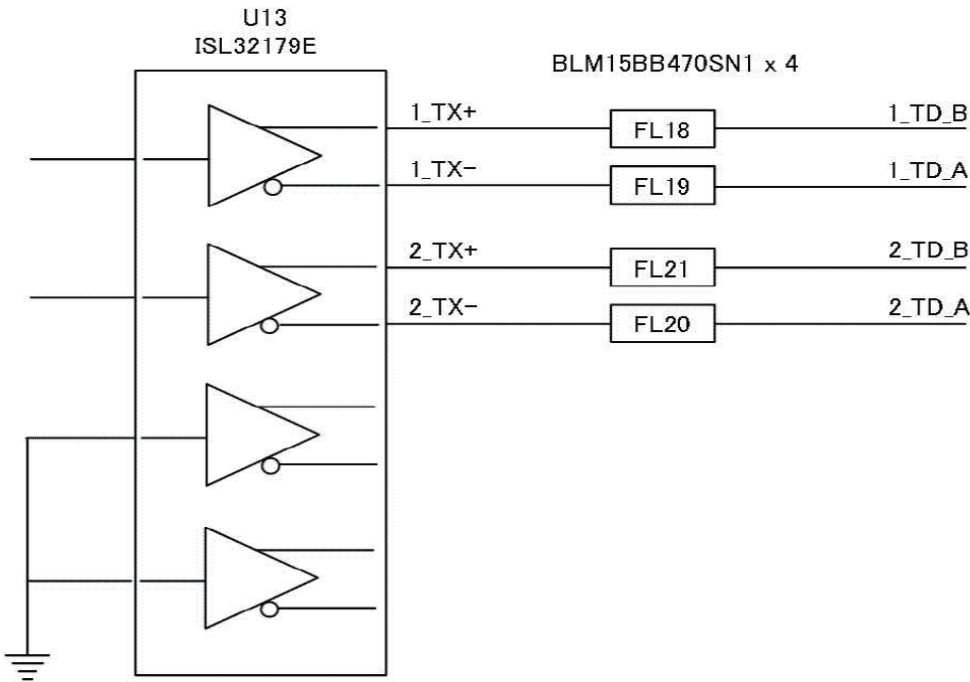

Serial Interface: IEC61162-2

- Data Collecting Unit, input

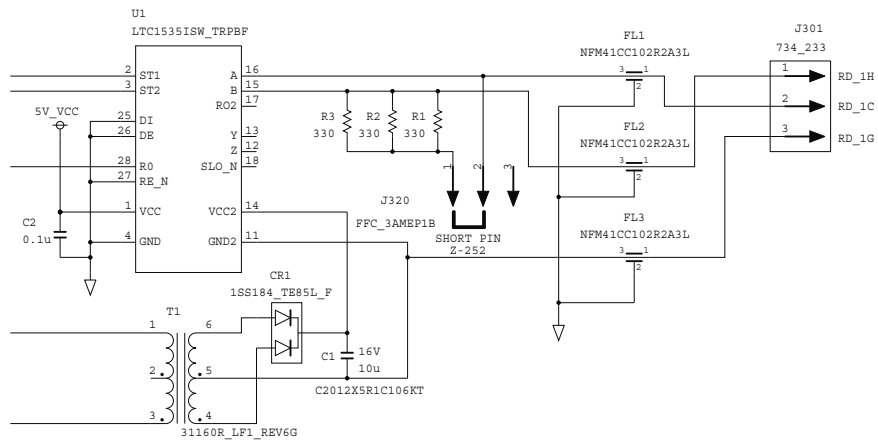

Serial Interface: IEC61162-450

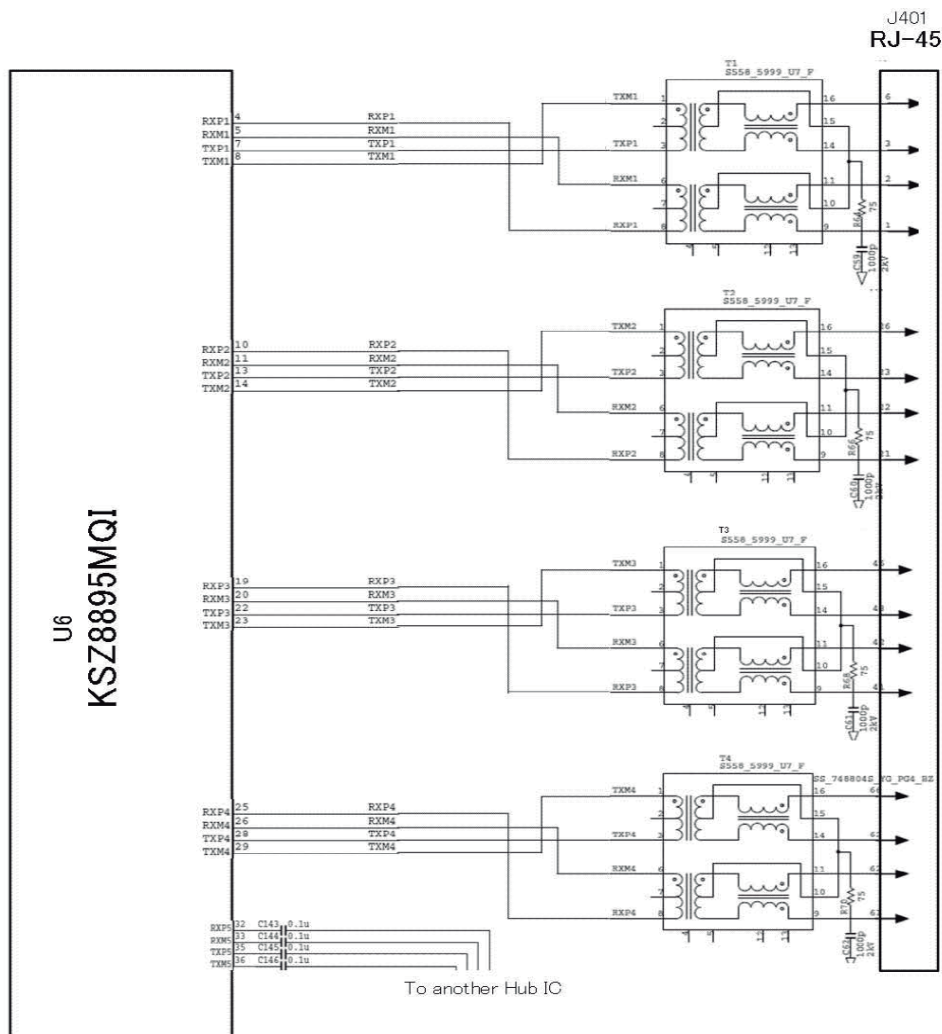

APPENDIX 5 CODING OF THE FLOAT-FREE DRU

Similarly to a satellite EPIRB (Emergency Position Indicate Radio Beacon), the capsule of the float-free DRU is coded before installation. The ship’s MMSI, name, call sign, etc. are recorded to the capsule during coding, and this information is indicated on the capsule.

The expiration date of both the battery in the capsule and the hydrostatic release unit is coded into the capsule of the float-free DRU as shown below.

Battery in the capsule

The expiration date of the battery is calculated from the year and month of manufacture. The year and month manufacture for the battery is indicated on the sticker at the side of the capsule.

The year and month of manufacture



The expiration date is calculated as follows;

- Year and month of coding ≤ Year and month of manufacture + 2.5 years:
The expiration date is 5 years after the year and month of coding.
- Year and month of coding > Year and month of manufacture + 2.5 years:
This battery cannot be used.

The calculated expiration date is marked as follows;

Example: When the expiration date is April 2019.

The expiration date is indicated on this sticker.

“2019” is cut out or filled with a permanent marker.

	2017	2018	2019	2020	2021	2022
Manufacture year number	Battery type: 67459 (Class 2) Lithium metal 7.2 V / 18Ah Operation: >168 hrs., -20°C to +68°C (-4°F to +130°F) Storage: -30°C to +70°C (-22°F to +158°F)					
	1	2	3	4	5	6
	7	8	9	10	11	12

“4” is cut out or filled with a permanent marker.

Hydrostatic release unit

The expiration date of the hydrostatic release unit is 2 years after the year and month of coding. The expiration date is indicated on the sticker attached on the side of the unit and sticker on the side of the bracket.

- For the sticker attached on the side of the unit:

Example: When the expiration date is June 2016.



The number below “2016” is cut out or filled with a permanent marker.



The number below “JUN” is cut out or filled with a permanent marker.

- For the sticker on the side of the bracket:

The expiration date is inscribed here.

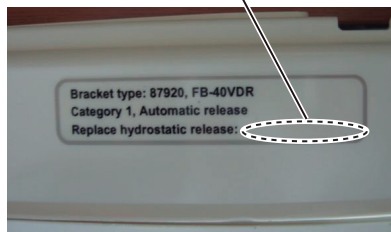
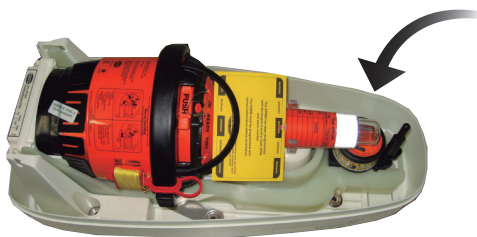

PACKING LIST
VR-7010-#V, VR-7010-#HKV

2440-X-9852 -2 1/1

A-1

NAME	OUTLINE	DESCRIPTION/CODE No.	Q'TY
ユニット UNIT			
データ収集ユニット DATA COLLECTING UNIT		VR-7010-# 000-025-262-00 **	1
付属品 ACCESSORIES			
インストールソフト&図書CD INSTALL SOFT & MANUAL CD		VR-7030 SW&MANUAL CD 000-191-754-1*	1
ケーブル組品LAN LAN CABLE ASSEMBLY		MOD-Z072-020+ 001-167-880-10	1
付属品 ACCESSORIES		FP24-01102	1
付属品 ACCESSORIES		001-279-070-00 FP24-01112 001-279-080-00	(*1) 1 (*2)
工事材料 INSTALLATION MATERIALS			
工事材料 INSTALLATION MATERIALS		CP24-03301 001-279-040-00	1
図書 DOCUMENT			
操作要領書 OPERATOR'S GUIDE		OS*-44850-# 000-179-343-1* **	1
装備要領書 INSTALLATION MANUAL		IM*-44850-# 000-192-319-1* **	1

- 1.コード番号末尾の[*]は、選択品の代表コードを表します。
 1.CODE NUMBER ENDING WITH "*" INDICATES THE CODE NUMBER OF REPRESENTATIVE MATERIAL.
 2.(*1)は、和文仕様用です。
 2.(*1) IS FOR JAPANESE SET.
 3.(*2)は、英文仕様用です。
 3.(*2) IS FOR ENGLISH SET.

(略図の寸法は、参考値です。DIMENSIONS IN DRAWING FOR REFERENCE ONLY.)

C4485-Z03-C

PACKING LIST
VR-7017-MIJ, VR-7017-S-MIJ

2440-X-9853 -2 1/1

A-2

NAME	UNIT	DESCRIPTION/CODE No.	Q'TY
ユニット UNIT			
リモコン REMOTE ALARM PANEL		VR-7017*-MIJ 000-028-685-00 **	1
工事材料 INSTALLATION MATERIALS			
工事材料 INSTALLATION MATERIALS		CP24-03401 001-279-100-00	1

- 1.コード番号末尾の[*]は、選択品の代表コードを表します。
 1.CODE NUMBER ENDING WITH "*" INDICATES THE CODE NUMBER OF REPRESENTATIVE MATERIAL.

(略図の寸法は、参考値です。DIMENSIONS IN DRAWING FOR REFERENCE ONLY.)



C4485-Z04-C

PACKING LIST

2440-X-9854 -2 1/1

A-3

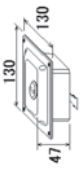
VR-7011-MIJ

NAME	OUTLINE	DESCRIPTION/CODE No.	QTY
ユニット マイクロホン		VR-7011-MIJ 000-028-681-00	1
工事材料 INSTALLATION MATERIALS			
工事材料		CP24-03501 001-279-130-00	1
INSTALLATION MATERIALS			

(略図の寸法は、参考値です。DIMENSIONS IN DRAWING FOR REFERENCE ONLY.)



C4485-Z05-C

PACKING LIST

2440-X-9855 -2 1/1

A-4

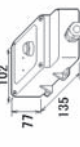
VR-7012W-MIJ

NAME	OUTLINE	DESCRIPTION/CODE No.	QTY
ユニット 防水型マイク		VR-7012W-MIJ 000-028-683-00	1
工事材料 INSTALLATION MATERIALS			
工事材料		CP24-03601 001-279-140-00	1
INSTALLATION MATERIALS			

(略図の寸法は、参考値です。DIMENSIONS IN DRAWING FOR REFERENCE ONLY.)

C4485-Z06-C

PACKING LIST

IF-7100 , IF-7100-HK

2440-X-9856 -0

1/1

A-5

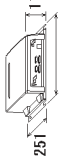
NAME	UNIT	OUTLINE	DESCRIPTION/CODE No.	Q'TY
ユニット ビデオLANコンバータ			IF-7100* 000-025-278-00 **	1
予備品				
予備品			SP24-01201 001-279-110-00	1
工事材料				
工事材料			CP24-03701 001-279-120-00	1
INSTALLATION MATERIALS				

コード番号末尾の[**]は、選択品の代表コードを表します。
CODE NUMBER ENDING WITH "。**" INDICATES THE CODE NUMBER OF REPRESENTATIVE MATERIAL.

型式/コード番号が2段の場合、下段より上段に代わる過渡期品であり、どちらが入っています。なお、品質は変わりません。
TWO TYPES AND CODES MAY BE LISTED FOR AN ITEM. THE LOWER PRODUCT MAY BE SHIPPED IN PLACE OF THE UPPER PRODUCT. QUALITY IS THE SAME.
(略図の寸法は、参考値です。DIMENSIONS IN DRAWING FOR REFERENCE ONLY.)

C4485-Z07-A

PACKING LIST

MC-3000S

24AL-X-9858 -2

1/1

A-6

NAME	UNIT	OUTLINE	DESCRIPTION/CODE No.	Q'TY
ユニット センサーアダプター			MC-3000S 000-020-522-00	1
予備品				
予備品			SP24-00701 001-370-670-00	1
工事材料				
工事材料			CP24-02401 001-370-680-00	1
INSTALLATION MATERIALS				

型式/コード番号が2段の場合、下段より上段に代わる過渡期品であり、どちらが入っています。なお、品質は変わりません。
TWO TYPES AND CODES MAY BE LISTED FOR AN ITEM. THE LOWER PRODUCT MAY BE SHIPPED IN PLACE OF THE UPPER PRODUCT. QUALITY IS THE SAME.
(略図の寸法は、参考値です。DIMENSIONS IN DRAWING FOR REFERENCE ONLY.)



C4473-Z05-C

PACKING LIST

03GM-X-9858 -0 1/1

PSU-011

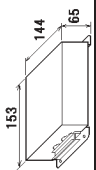
A-7

NAME	UNIT	OUTLINE	DESCRIPTION/CODE	Q.TY
電源制御部 POWER CONTROL UNIT			PSU-011 000-010-324-00	1
工事材料 INSTALLATION MATERIALS				
工事材料 INSTALLATION MATERIALS			CP03-31701 001-013-670-00	1

型式/コード番号が2段の場合、下段より上段に代わる過渡期品であり、どちらが入っています。なお、品質は変わりません。
TWO TYPES AND CODES MAY BE LISTED FOR AN ITEM. THE LOWER PRODUCT MAY BE SHIPPED IN PLACE OF THE UPPER PRODUCT. QUALITY IS THE SAME.
(縮図の寸法は、参考値です。DIMENSIONS IN DRAWING FOR REFERENCE ONLY.)

C3527-Z03-A

FURUNO

A-8

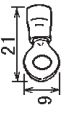
CODE NO. TYPE	001-013-670-00 CP03-31701	03GM-X-9405 -0	1/1
工事材料表 INSTALLATION MATERIALS			
番号 NO.	名称 NAME	略図 OUTLINE	用途 / 備考 REMARKS
1	圧着端子 CRIMP-ON LUG		
		F12-4 CODE NO.	数量 Q.TY
		000-157-247-10	4

型式/コード番号が2段の場合、下段より上段に代わる過渡期品であり、どちらが入っています。なお、品質は変わりません。
TWO TYPES AND CODES MAY BE LISTED FOR AN ITEM. THE LOWER PRODUCT MAY BE SHIPPED IN PLACE OF THE UPPER PRODUCT. QUALITY IS THE SAME.
(縮図の寸法は、参考値です。DIMENSIONS IN DRAWING FOR REFERENCE ONLY.)

FURUNO ELECTRIC CO., LTD.

C3527-I104-A

CODE NO.	001-279-040-00	2440-X-9401-2	1/1
TYPE	CP24-03301		

工事材料表

番号 NO.	名称 NAME	略図 OUTLINE	型名/規格 DESCRIPTIONS	数量 QTY	用途/備考 REMARKS
1	フェリス(鉄)クリムピング FERRULE CRIMPING TERMINAL		A 1.5-10 CODE NO. 000-179-370-10	10	
2	フェリス(鉄)クリムピング FERRULE CRIMPING TERMINAL		A1 1.5-6 BK CODE NO. 000-176-412-10	5	
3	化粧キャップ COSMETIC CAP		CP-30-BG-10-BLACK CODE NO. 000-179-377-10	2	
4	モジュラーコネクタ MODULAR CONNECTOR		MPS588-C CODE NO. 000-166-044-10	15	
5	ケーブルバンド CABLE BAND		PLFIN-M CODE NO. 000-116-922-10	40	

型式/コード番号が2段の場合、下段より上段に代わる通線部品であり、どちらが入っています。なお、品質は変わりません。
TWO TYPES AND CODES MAY BE LISTED FOR AN ITEM. THE LOWER PRODUCT MAY BE SHIPPED IN PLACE OF THE UPPER PRODUCT.
QUALITY IS THE SAME.
(略図の寸法は、参考値です。 DIMENSIONS IN DRAWING FOR REFERENCE ONLY.)

CODE NO.	001-279-100-00	2440-X-9402-0	1/1
TYPE	CP24-03401		



工事材料表

番号 NO.	名称 NAME	略図 OUTLINE	型名/規格 DESCRIPTIONS	数量 QTY	用途/備考 REMARKS
1	+17777777 SELF TAPPING SCREW		4X16 SUS304 CODE NO. 000-102-609-10	4	

型式/コード番号が2段の場合、下段より上段に代わる通線部品であり、どちらが入っています。なお、品質は変わりません。
TWO TYPES AND CODES MAY BE LISTED FOR AN ITEM. THE LOWER PRODUCT MAY BE SHIPPED IN PLACE OF THE UPPER PRODUCT.
QUALITY IS THE SAME.
(略図の寸法は、参考値です。 DIMENSIONS IN DRAWING FOR REFERENCE ONLY.)

CODE NO.	001-279-130-00	2440-X-9403-0	1/1
TYPE	CP24-03501		

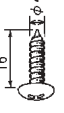
工事材料表

INSTALLATION MATERIALS			
番号 NO.	名称 NAME	略図 OUTLINE	数量 QTY
1	セルフタッピングビス 1/2		4
		4X16 SUS304 CODE NO. 000-162-605-10	
2	ケーブルタイ CABLE TIE		1
		CV-150N CODE NO. 000-162-186-10	

型式/コード番号が2段の場合、下段より上段に代わる通線用品であり、どちらが入っています。なお、品質は変わりません。
TWO TYPES AND CODES MAY BE LISTED FOR AN ITEM. THE LOWER PRODUCT MAY BE SHIPPED IN PLACE OF THE UPPER PRODUCT.
QUALITY IS THE SAME.
(略図の寸法は、参考値です。DIMENSIONS IN DRAWING FOR REFERENCE ONLY.)

CODE NO.	001-279-140-00	2440-X-9404-1	1/1
TYPE	CP24-03501		

工事材料表

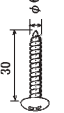
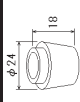
INSTALLATION MATERIALS			
番号 NO.	名称 NAME	略図 OUTLINE	数量 QTY
1	セルフタッピングビス 1/2		4
		GX30 SUS304 CODE NO. 000-162-614-10	
2	スリーブ SLEEVE/RUBBER		1
		SC-4837 CODE NO. 000-100-346-10	

型式/コード番号が2段の場合、下段より上段に代わる通線用品であり、どちらが入っています。なお、品質は変わりません。
TWO TYPES AND CODES MAY BE LISTED FOR AN ITEM. THE LOWER PRODUCT MAY BE SHIPPED IN PLACE OF THE UPPER PRODUCT.
QUALITY IS THE SAME.
(略図の寸法は、参考値です。DIMENSIONS IN DRAWING FOR REFERENCE ONLY.)

FURUNO

CODE NO.	001-279-120-00	2440-X-9405-1
TYPE	CP24-03701	1/1

工事材料表

番号 NO.	名称 NAME	略図 OUTLINE	型名/規格 DESCRIPTIONS	数量 QTY	用途/備考 REMARKS
1	フェレット FERRULE CRIMPING TERMINAL		A 1.5-10 CODE NO. 000-179-870-10	5	
2	コネクタ CABLE TIE		CV-150N CODE NO. 000-162-186-10	3	
3	六角ナット 1/2 HEX. NUT		M8 SUS304 CODE NO. 000-167-479-10	4	
4	平丸平座金 FLAT WASHER		M8 SUS304 CODE NO. 000-167-464-10	4	
5	ハネ座金 SPRING WASHER		M8 SUS304 CODE NO. 000-167-410-10	4	
6	六角ナット 六角ナット HEXAGONAL HEAD BOLT		M8X25 SUS304 CODE NO. 000-162-879-10	4	

型式/コード番号が2段の場合、下段より上段に代わる過渡製品であり、どちらが入っています。なお、品質は変わりません。
TWO TYPES AND CODES MAY BE LISTED FOR AN ITEM. THE LOWER PRODUCT MAY BE SHIPPED IN PLACE OF THE UPPER PRODUCT.
QUALITY IS THE SAME.
(略図の寸法は、参考値です。 DIMENSIONS IN DRAWING FOR REFERENCE ONLY.)

FURUNO ELECTRIC CO., LTD.

C4485-M05-B

FURUNO

CODE NO.	001-319-050-00	2440-X-9407-2
TYPE	CP24-03801	1/1

工事材料表

番号 NO.	名称 NAME	略図 OUTLINE	型名/規格 DESCRIPTIONS	数量 QTY	用途/備考 REMARKS
1	フェレット FERRULE		AT 0.14-8 BY-1000 CODE NO. 000-176-689-10	10	
2	フェレット フェレット FERRULE CRIMPING TERMINAL		AT 1.5-6 BK CODE NO. 000-176-412-10	5	
3	ハネ座金 SPRING WASHER		M12 SUS316L CODE NO. 000-167-396-10	3	
4	平座金 FLAT WASHER		M12 SUS316L CODE NO. 000-167-417-10	6	
5	六角ナット 1/2 HEXAGONAL NUT		M12 SUS316L CODE NO. 000-167-494-10	3	
6	六角ナット 刻印付 HEXAGONAL HEAD BOLT		M12X45 SUS316L CODE NO. 000-178-722-10	3	
7	フェレット シリコン SILICON RUBBER		S-8400W 50G CODE NO. 000-158-483-12	1	

(略図の寸法は、参考値です。 DIMENSIONS IN DRAWING FOR REFERENCE ONLY.)

FURUNO ELECTRIC CO., LTD.

C4485-M07-C

FURUNO

CODE NO.	001-319-060-00	2440-X-9408-1	1/1
TYPE	CP24-03901		

工事材料表

INSTALLATION MATERIALS			
番号 NO.	名称 NAME	略図 OUTLINE	数量 QTY
1	シリコング SILICONE SEALANT		1
			000-189-299-10
			000-189-299-10
			用途/備考 REMARKS

型式/コード番号が2取の場合、下取より上取に代わる運送梱包品であり、どちらが入っています。なお、品質は変わりません。
TWO TYPES AND CODES MAY BE LISTED FOR AN ITEM. THE LOWER PRODUCT MAY BE SHIPPED IN PLACE OF THE UPPER PRODUCT.
QUALITY IS THE SAME.
(略図の寸法は、参考値です。DIMENSIONS IN DRAWING FOR REFERENCE ONLY.)



FURUNO ELECTRIC CO., LTD.

C4485-M08-B

FURUNO

CODE NO.	001-321-640-00	2440-X-9409-2	1/1
TYPE	CP24-04001		

工事材料表

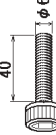
INSTALLATION MATERIALS			
番号 NO.	名称 NAME	略図 OUTLINE	数量 QTY
1	八神瓦 SPRING WASHER		6
			000-167-409-10
2	平座金 FLAT WASHER		6
			000-167-420-10
3	六角ナット HEXAGONAL NUT		12
			000-167-499-10
4	六角穴付ネジ HEXAGONAL HEAD BOLT		6
			000-162-749-10
			用途/備考 REMARKS

型式/コード番号が2取の場合、下取より上取に代わる運送梱包品であり、どちらが入っています。なお、品質は変わりません。
TWO TYPES AND CODES MAY BE LISTED FOR AN ITEM. THE LOWER PRODUCT MAY BE SHIPPED IN PLACE OF THE UPPER PRODUCT.
QUALITY IS THE SAME.
(略図の寸法は、参考値です。DIMENSIONS IN DRAWING FOR REFERENCE ONLY.)





FURUNO ELECTRIC CO., LTD.

C4485-M09-C

FURUNO

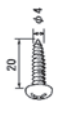
CODE NO.	001-370-680-00	24AL-X-9404-3	1/1
TYPE	CP24-02401		

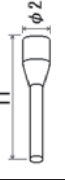
工事材料表

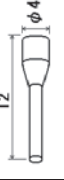
番号 NO.	名称 NAME	略図 OUTLINE	型名/規格 DESCRIPTIONS	数量 QTY	用途/備考 REMARKS
1	セルフタッピングネジ 1/2 SELF-TAPPING SCREW		4XZ0 SUB304 CODE NO. 000-155-850-10	4	
2	フェラ FERRULE		A1 0.14-8 GT-1000 CODE NO. 000-176-609-10	10	
3	フェラ FERRULE		A1 0.34-6 10 CODE NO. 000-176-410-10	10	
4	フェラ FERRULE		A1 1.75-6 GT CODE NO. 000-176-411-10	40	
5	フェラ FERRULE CRIMPING TERMINAL		A1 1.5-6 BK CODE NO. 000-176-412-10	10	

型式/コード番号が2図の場合、下図より上図に代わる通線部品であり、どちらが入っています。なお、品質は変わりません。
TWO TYPES AND CODES MAY BE LISTED FOR AN ITEM. THE LOWER PRODUCT MAY BE SHIPPED IN PLACE OF THE UPPER PRODUCT.
QUALITY IS THE SAME.
(略図の寸法は、参考値です。 DIMENSIONS IN DRAWING FOR REFERENCE ONLY.)

FURUNO ELECTRIC CO., LTD.

C4473-104-D

FURUNO

CODE NO.	001-279-080-00	24AO-X-9504-0	1/1
TYPE	FP24-01112		

付属品表

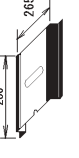
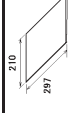
番号 NO.	名称 NAME	略図 OUTLINE	型名/規格 DESCRIPTIONS	数量 QTY	用途/備考 REMARKS
1	カードホルダ CARD HOLDER		C-26-27-2-1 CODE NO. 000-165-407-10	1	
2	データ抽出要領 DATA EXTRACTION PROCEDURE		E42-01402-6 CODE NO. 000-179-354-16	1	

型式/コード番号が2図の場合、下図より上図に代わる通線部品であり、どちらが入っています。なお、品質は変わりません。
TWO TYPES AND CODES MAY BE LISTED FOR AN ITEM. THE LOWER PRODUCT MAY BE SHIPPED IN PLACE OF THE UPPER PRODUCT.
QUALITY IS THE SAME.
(略図の寸法は、参考値です。 DIMENSIONS IN DRAWING FOR REFERENCE ONLY.)

FURUNO ELECTRIC CO., LTD.

C4485-F04-A

FURUNO

CODE NO.	001-279-030-00	2440-X-9301-2	1/1
TYPE	SP24-01101	BOX NO.	P

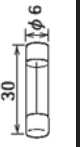
SHIP NO.	SPARE PARTS LIST FOR		U S E			REMARKS/CODE NO.
			WORKING	SPARE	SETS PER VESSEL	
ITEM NO.	NAME OF PART	OUTLINE	DWG. NO. OR TYPE NO.	QUANTITY PER SET	PER VES	
1	GLASS TUBE FUSE		FG80-A 250V 10A PBF	2	2	6
			000-155-839-10			
MFR'S NAME	FURUNO ELECTRIC CO., LTD.		DWG NO.	C4485-P01-C		1/1

(略図の寸法は、参考値です。 DIMENSIONS IN DRAWING FOR REFERENCE ONLY.)

FURUNO

CODE NO.	001-279-110-00	2440-X-9302-2	1/1
TYPE	SP24-01201	BOX NO.	P

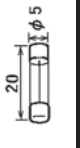
SHIP NO.	SPARE PARTS LIST FOR		U S E			REMARKS/CODE NO.
			WORKING	SPARE	SETS PER VESSEL	
ITEM NO.	NAME OF PART	OUTLINE	DWG. NO. OR TYPE NO.	QUANTITY PER SET	PER VES	
1	GLASS TUBE FUSE		FGMB-A 125V 2A PBF	1	1	3
			000-157-479-10			
MFR'S NAME	FURUNO ELECTRIC CO., LTD.		DWG NO.	C4485-P02-C		1/1

(略図の寸法は、参考値です。 DIMENSIONS IN DRAWING FOR REFERENCE ONLY.)



表1 TABLE 1

寸法区分 (mm) DIMENSION	公差 (mm) TOLERANCE
$L \leq 50$	± 1.5
$50 < L \leq 100$	± 2.5
$100 < L \leq 500$	± 3
$500 < L \leq 1000$	± 4

- 注記 1) 指定外の寸法公差は表1による。
 2) #印寸法は最小サービス空間寸法とする。
 3) 取付用ネジはM10ボルト又はコーチボルト呼び10を使用のこと。

- NOTE 1. TABLE 1 INDICATES TOLERANCE OF DIMENSIONS WHICH IS NOT SPECIFIED.
 2. #: MINIMUM SERVICE CLERANCE.
 3. USE M10 BOLTS OR COARCH SCREWS $\phi 10$ FOR FIXING THE UNIT.

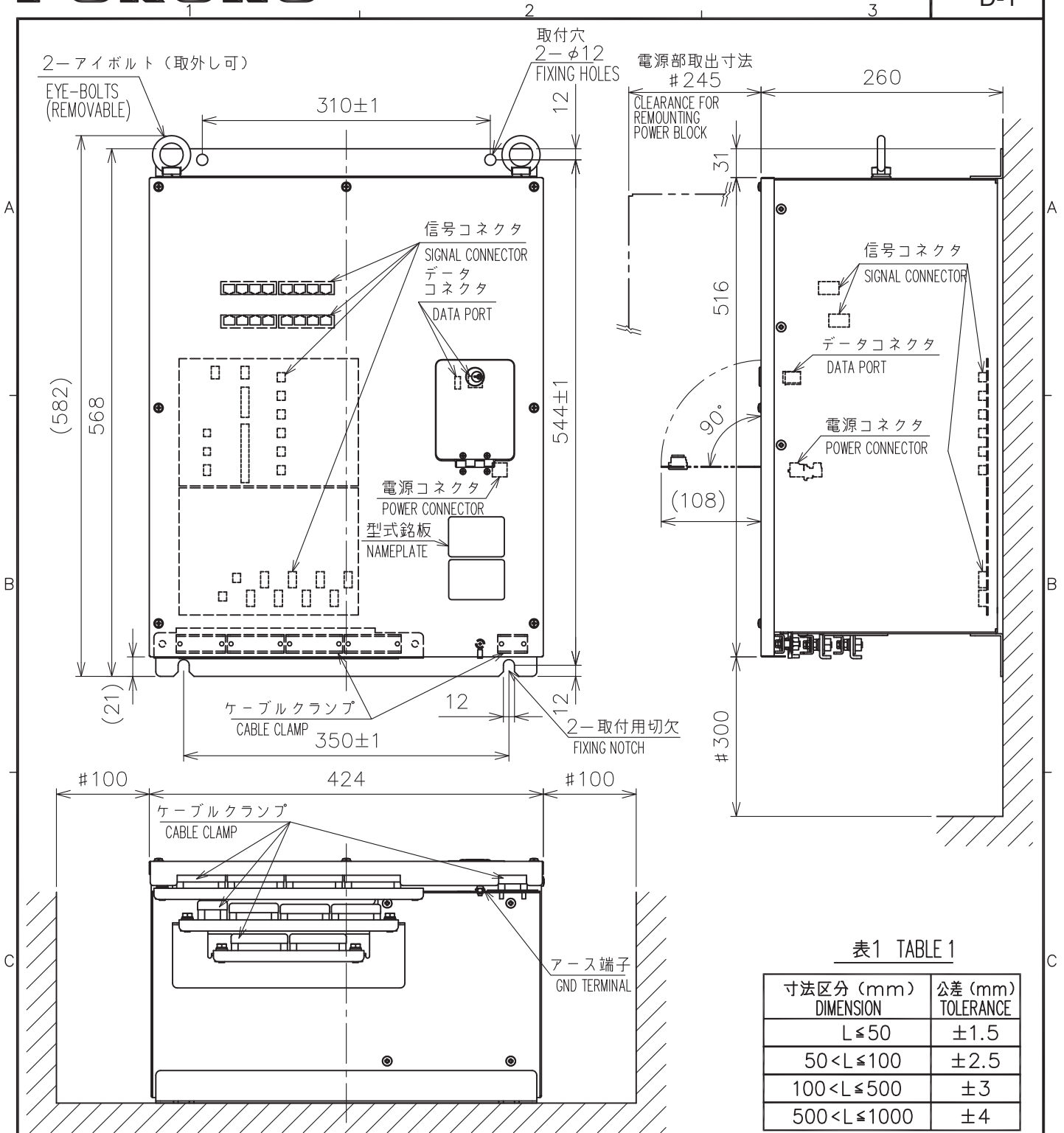
DRAWN 1/Jul/2014 T.YAMASAKI	TITLE VR-7010
CHECKED 1/Jul/2014 H.MAKI	名称 データ収集ユニット
APPROVED 2/Jul/2014 H.MAKI	外寸図
SCALE 1/6 MASS 29 $\pm 10\%$ kg	NAME DATA COLLECTING UNIT
DWG. No. C4485-G01-C	REF. No. 24-015-100G-2
OUTLINE DRAWING	

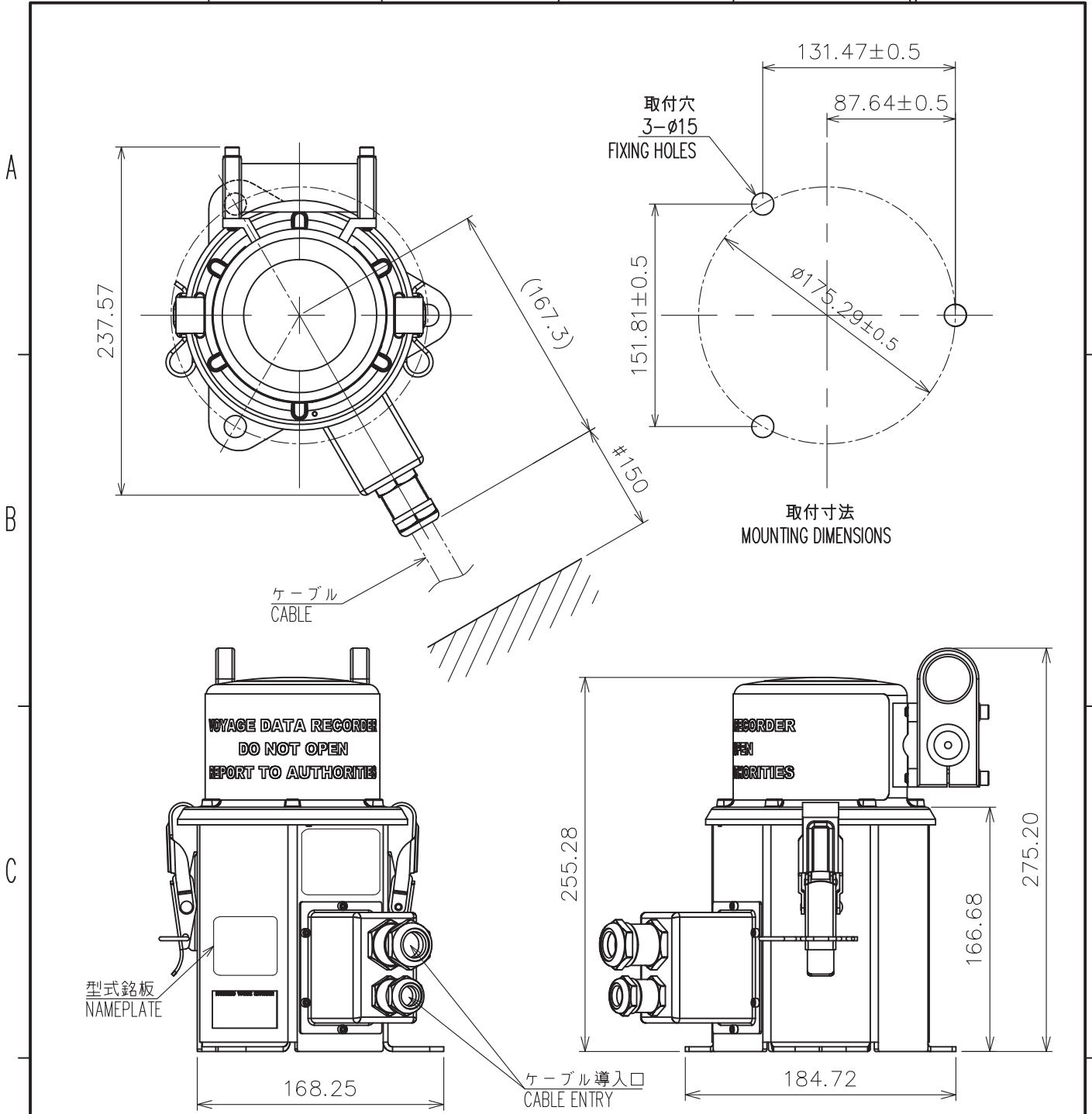

注記

- 1) 指定なき寸法公差は表1による。
- 2) #印寸法は最小サービス空間寸法とする。
- 3) 取付用ネジはM12ボルトを使用のこと。

NOTE

1. TABLE 1 INDICATES TOLERANCE OF DIMENSIONS WHICH IS NOT SPECIFIED.
2. #: MINIMUM SERVICE CLEARANCE.
3. USE M12 BOLTS FOR FIXING THE UNIT.

表1 TABLE 1

寸法区分 (mm) DIMENSION	公差 (mm) TOLERANCE
$L \leq 50$	± 1.5
$50 < L \leq 100$	± 2.5
$100 < L \leq 500$	± 3

DRAWN 26/Jun/2014 T.YAMASAKI		TITLE VR-7020
CHECKED 26/Jun/2014 H.MAKI		名称 固定式データ記録器
APPROVED 27/Jun/2014 H.MAKI	VR-7000	外寸図
SCALE 1/4	MASS 7.3 $\pm 10\%$ kg	NAME FIXED DATA RECORDING UNIT
DWG. No. C4485-G06-C	REF. No. 24-015-430G-1	OUTLINE DRAWING

2 3 4

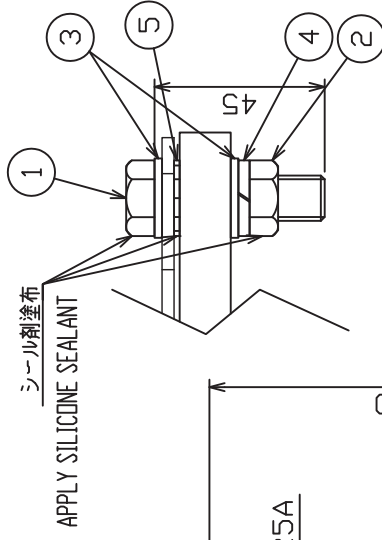
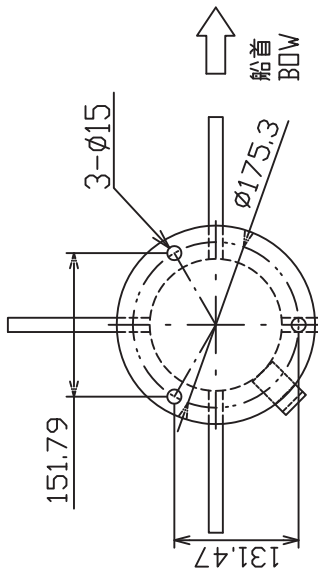
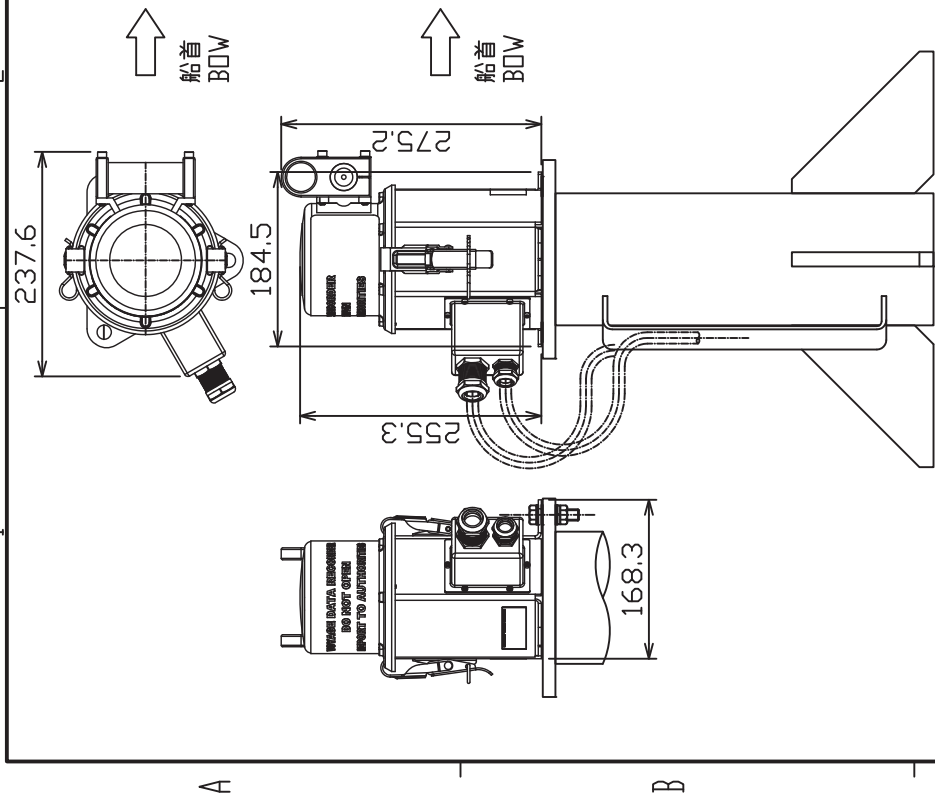

取付部詳細 (尺度: 1/2)
DETAIL FOR FIXING (SCALE: 1/2)

取付台作成例 (参考)
STANCHION (FOR REFERENCE)

注記

1) 取付台は造船所手配とする。

NOTE

1. STANCHION SHOULD BE PREPARED BY SHIPYARD.

5	取付蓋金 LOCK WASHER	3	M12	工率材料 INSTALLATION MATERIAL
4	六角蓋金 SPRING WASHER	3	M12	
3	平蓋金 PLANE WASHER	6	M12	
2	六角ナット HEX NUT	3	M12	
1	六角ボルト HEX BOLT	3	M12x45	
	品番 ITEM	材料名 MATERIAL	数量 QTY	備考 REMARKS
		品名 NAME	図番 FIG. NO.	
DRAWN		TITLE		
CHECKED		名称		
APPROVED		装置名		
SCALE		固定式データ記録器		
FIG. No.		準備要領		
		NAME		
		FIXED DATA RECORDING UNIT		
		INSTALLATION PROCEDURE		
		REF. No.		

31/JUL/2014	T.YAMASAKI
31/JUL/2014	H.MAKI
31/JUL/2014	H.MAKI
1/8	1/8
C4485-Y01-C	C4485-Y01-C

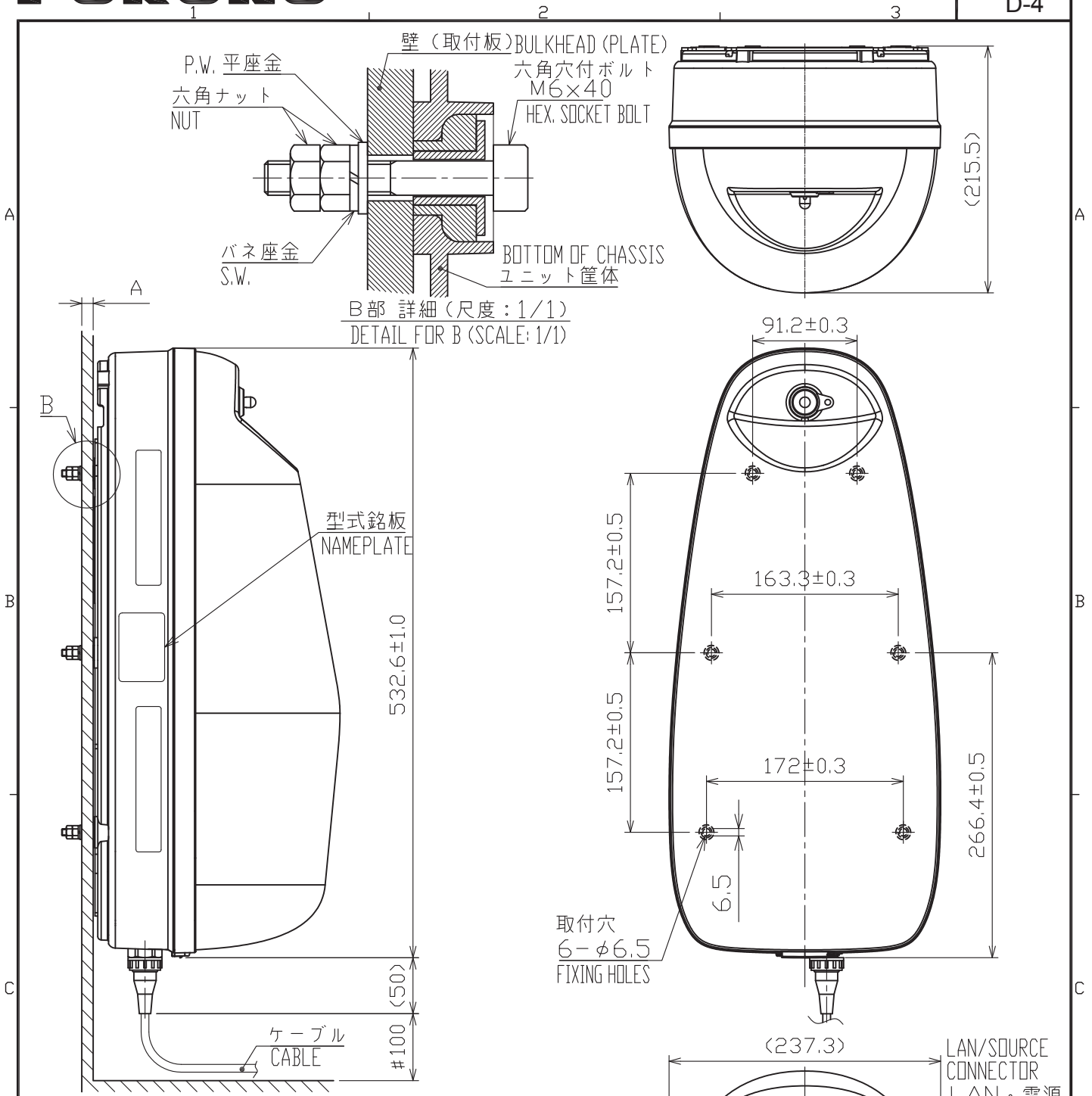

注 記

- 1) #印寸法は最小サービス空間寸法とする。
- 2) 図中の公差はユニットメーカーの記載公差である。
- 3) 取付用ネジはM6×40六角穴付きボルトを使用のこと。
- 4) 壁 (取付板) の厚さ (A) は4~10mmとする。

NOTE

1. #: MINIMUM SERVICE CLEARANCE.
2. TOLERANCES OF DIMENSIONS ARE INFORMATION FROM THE UNIT MAKER.
3. USE M6x40 SOCKET HEAD BOLTS FOR FIXING THE UNIT.
4. BULKHEAD THICKNESS (A): BETWEEN 4 AND 10.

DRAWN	3/Oct/2017	T.YAMASAKI	TITLE	VR-7021F (BRACKET)
CHECKED	3/Oct/2017	H.MAKI	名称	自己浮揚式データ記録器 (ケース)
APPROVED	4/Oct/2017	H.MAKI	VR-7000/7000S	外寸図
SCALE	1/5	MASS 4.8 ±10% kg	質量は記録器本体を含む。 MASS INCLUDES MAIN UNIT.	NAME
DWG.No.	C4485-G08-J	REF.No.	24-015-431G-3	FLOAT-FREE DATA RECORDING UNIT W/BRACKET
				OUTLINE DRAWING

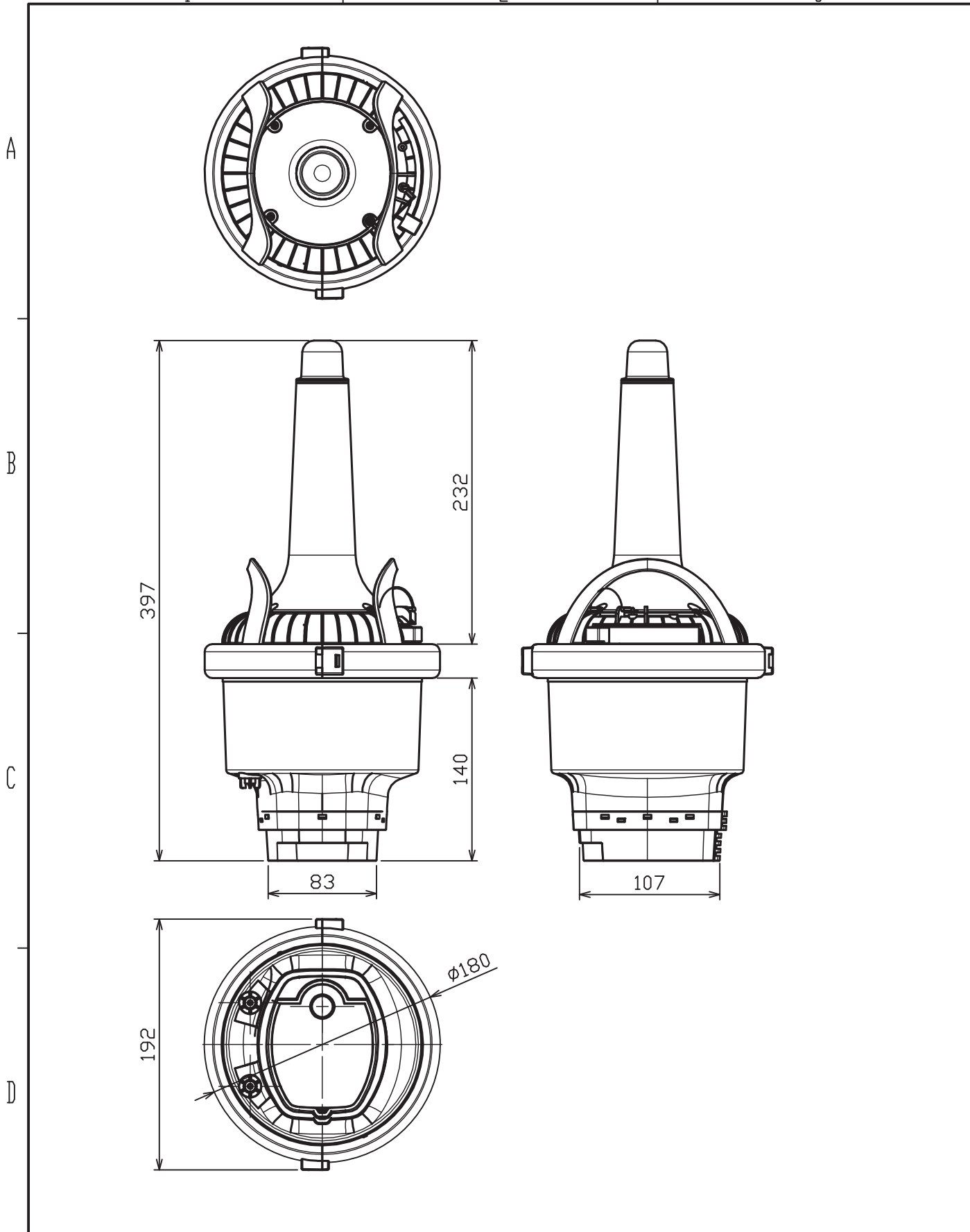

DRAWN 13/Mar/2014 T.YAMASAKI		TITLE VR-7021F	
CHECKED 13/Mar/2014 H.MAKI		名称 自己浮揚式データ記録器	
APPROVED 13/Mar/2014 H.MAKI		外寸図	
SCALE 1/4	MASS 1.9 $\pm 10\%$ kg	REF. No. M87910	NAME FLOAT-FREE DATA RECORDING UNIT
DWG. No. C4485-G07-B		OUTLINE DRAWING	

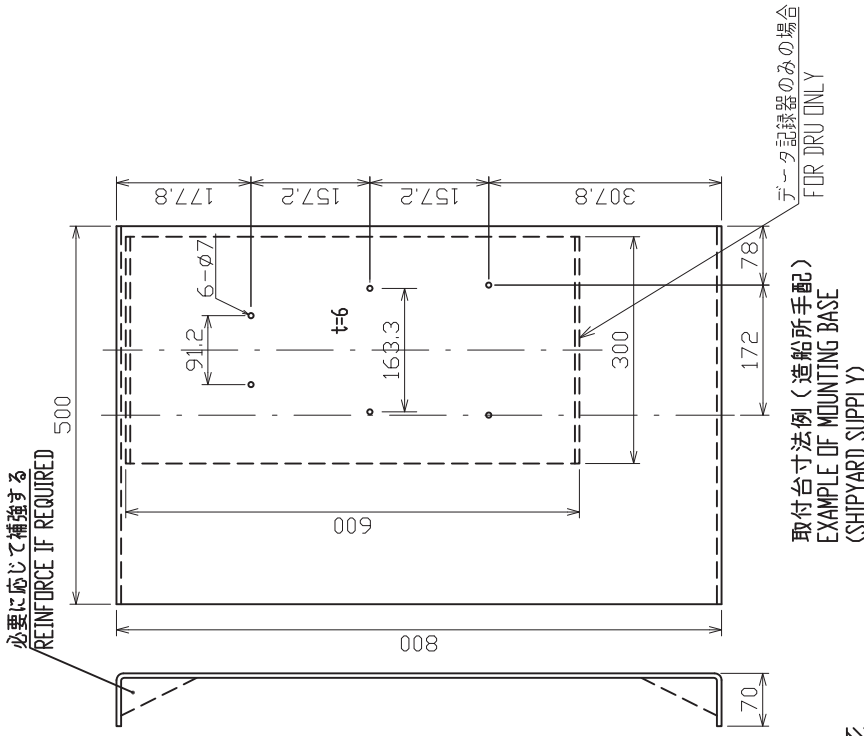
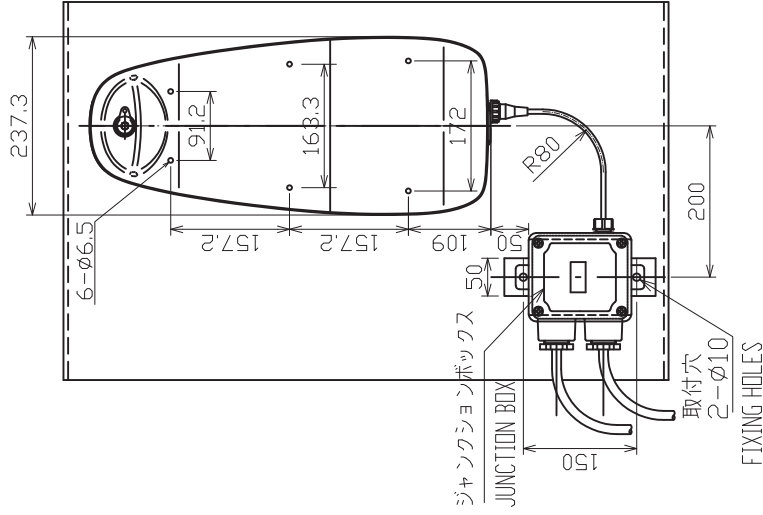
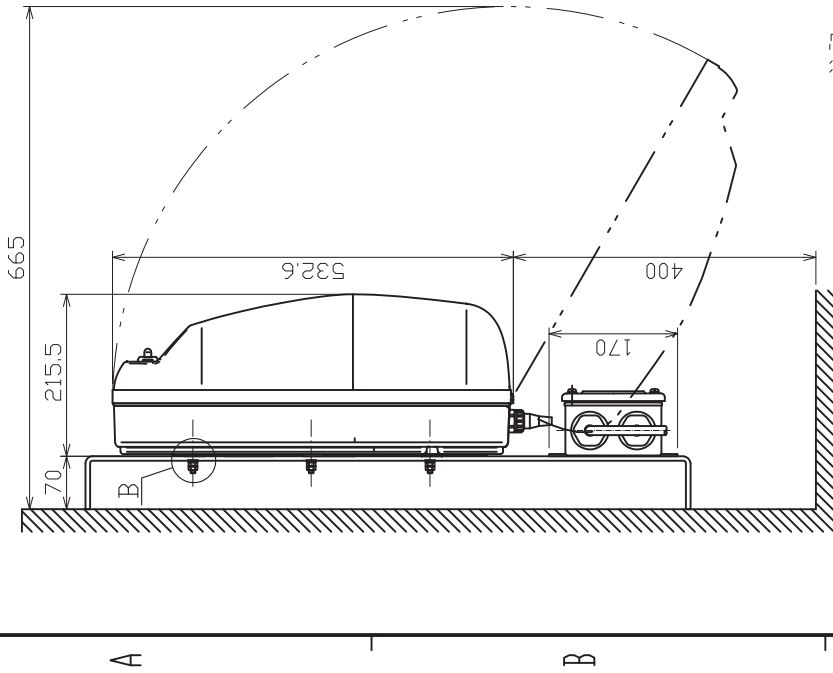

取付台寸法例 (造船所手配)
EXAMPLE OF MOUNTING BASE
(SHIPYARD SUPPLY)

データ記録器のみの場合
FOR DRU ONLY

注記

- 1) レーダー空中線部のRF信号にさらされない場所を選ぶこと。
- 2) VHFアンテナから5m以上離すこと。

NOTE

1. SELECT A PLACE WHERE IS NOT EXPOSED TO THE RF SIGNAL FROM RADAR ANTENNA.
2. KEEP THE UNIT 5m OR MORE AWAY FROM VHF ANTENNA.

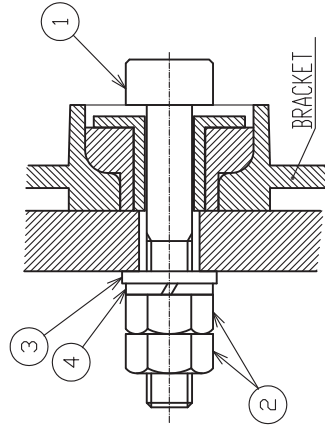

B部 詳細 (尺度: 1/1)
DETAIL FOR B (SCALE: 1/1)

4	バネ座金 SPRING WASHER	SUS316L	6	M6	工事材料 INSTALLATION MATERIAL
3	平座金 PLANE WASHER	SUS316L	6	M6	
2	六角ナット HEX NUT	SUS316L	12	M6	
1	六角六角付ボルト HEX SOCKET HEAD BOLT	SUS316L	6	M6x40	
	品名 ITEM	材料 MATERIAL	数量 QTY	図番 DIM. NO.	備註 REMARKS
DRAWN		TITLE		備註	
CHECKED		名称		備註	
APPROVED		自己浮揚式データ記録器		備註	
SCALE		NAME		備註	
DIM. No.		INSTALLATION PROCEDURE		備註	



表1 TABLE 1

寸法区分 (mm) DIMENSION	公差 (mm) TOLERANCE
L ≤ 50	±1.5
50 < L ≤ 100	±2.5
100 < L ≤ 500	±3

注記

- 1) 指定外寸法公差は表1による。
- 2) #印寸法は、最小サービスマン間寸法とする。
- 3) 取付ネジはトラスタップピンネジ呼び径4×16を使用のこと。

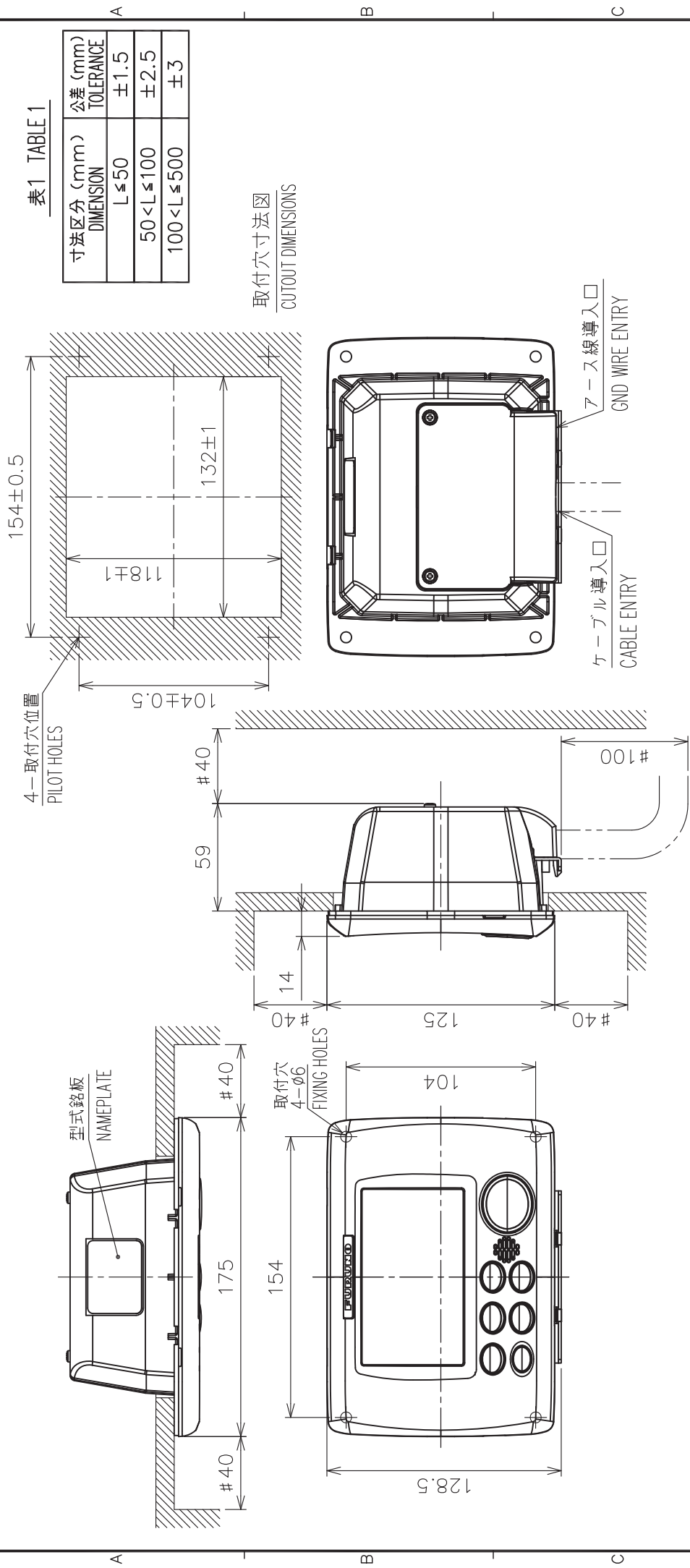
NOTE

1. TABLE 1 INDICATES TOLERANCE OF DIMENSIONS WHICH IS NOT SPECIFIED.
2. #: MINIMUM SERVICE CLEARANCE.
3. USE TAPPING SCREWS $\phi 4 \times 16$ FOR FIXING THE UNIT.

DRAWN	18/Jun/2014	I.YAMASAKI	TITLE	VR-7017
CHECKED	18/Jun/2014	H.MAKI	名称	リモートアラームパネル (埋込装備)
APPROVED	19/Jun/2014	H.MAKI	外寸図	
SCALE	1/3	質量はケーブルを含みず MASS DOES NOT INCLUDE CABLE.	NAME	REMOTE ALARM PANEL (FLUSH MOUNT)
DWG.No.	C4485-G10-B	REF.No.	24-015-202G-1	OUTLINE DRAWING



表1 TABLE 1

寸法区分 (mm) DIMENSION	公差 (mm) TOLERANCE
L ≤ 50	±1.5
50 < L ≤ 100	±2.5
100 < L ≤ 500	±3

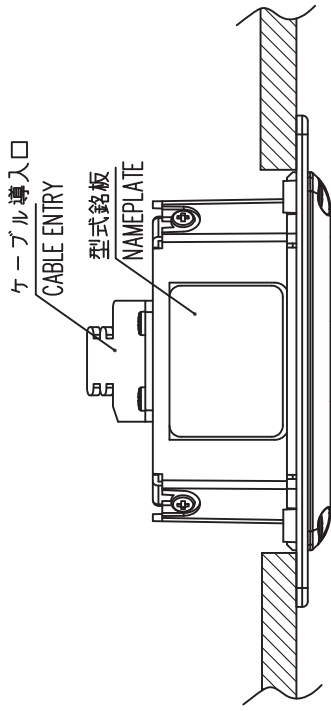
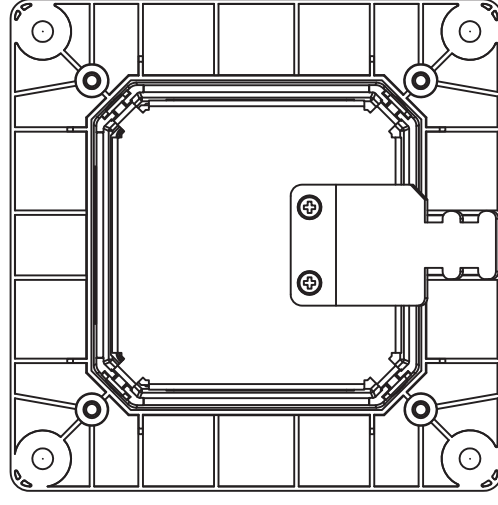
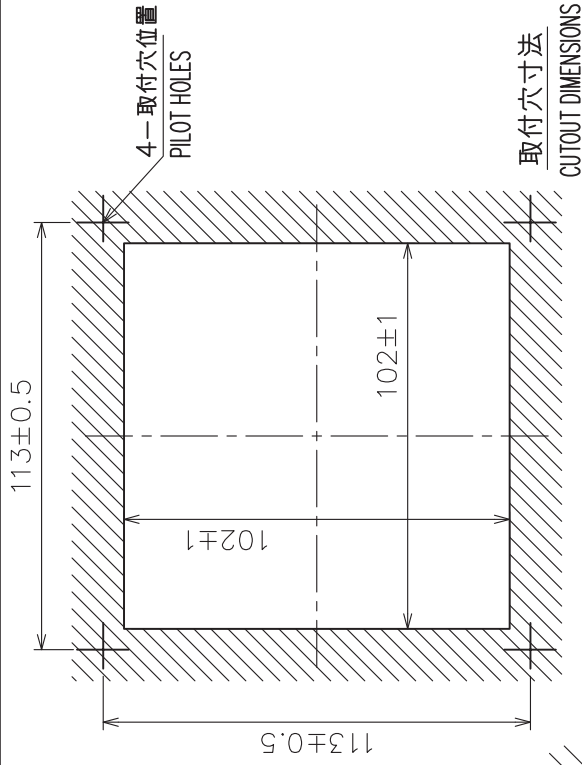
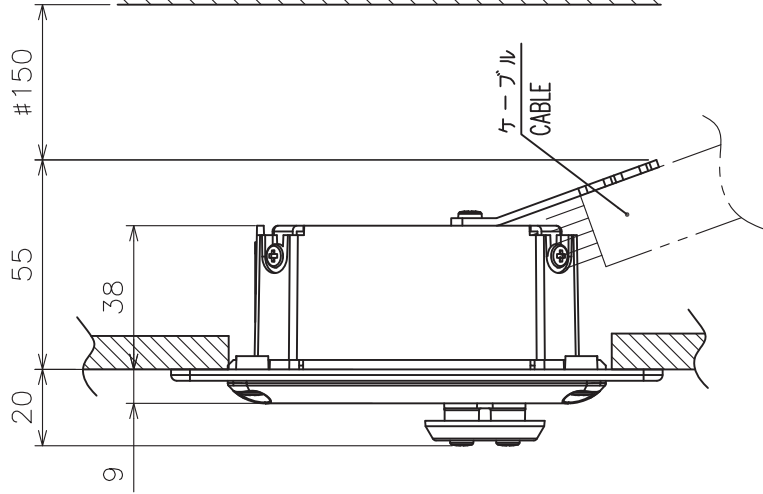
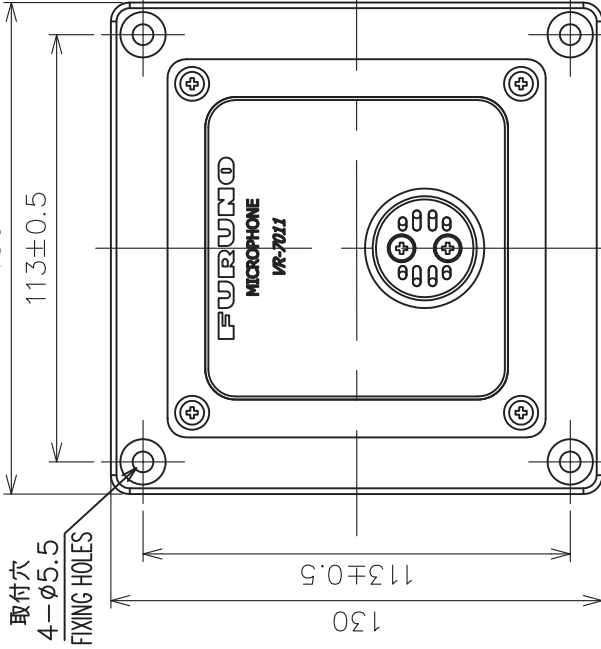

- 注記 1) 指定外の寸法公差は表 1 による。
 2) # 印寸法は最小サービスマウント寸法とする。
 3) 取付用ネジは、バインドタツピンネジ呼び径 4×1.6 を使用のこと。
- NOTE 1. TABLE 1 INDICATES TOLERANCE OF DIMENSIONS WHICH IS NOT SPECIFIED.
 2. # MINIMUM SERVICE CLEARANCE.
 3. USE BIND TAPPING SCREWS φ4x1.6 FOR FIXING THE UNIT.

DRAWN	18/Jun/2014	T.YAMASAKI	TITLE	VR-7011
CHECKED	18/Jun/2014	H.MAKI	名称	マイクロフォン (埋込装備)
APPROVED	19/Jun/2014	H.M.A.K.I	外寸図	
SCALE	1/2	質量はケーブルを含みず。 ±10% 質量はケーブルを含みず。 ±10% MASS DOES NOT INCLUDE CABLE.	NAME	MICROPHONE (FLUSH MOUNT)
DWG.No.	C4485-G04-B	REF.No.	24-015-400G-0	OUTLINE DRAWING

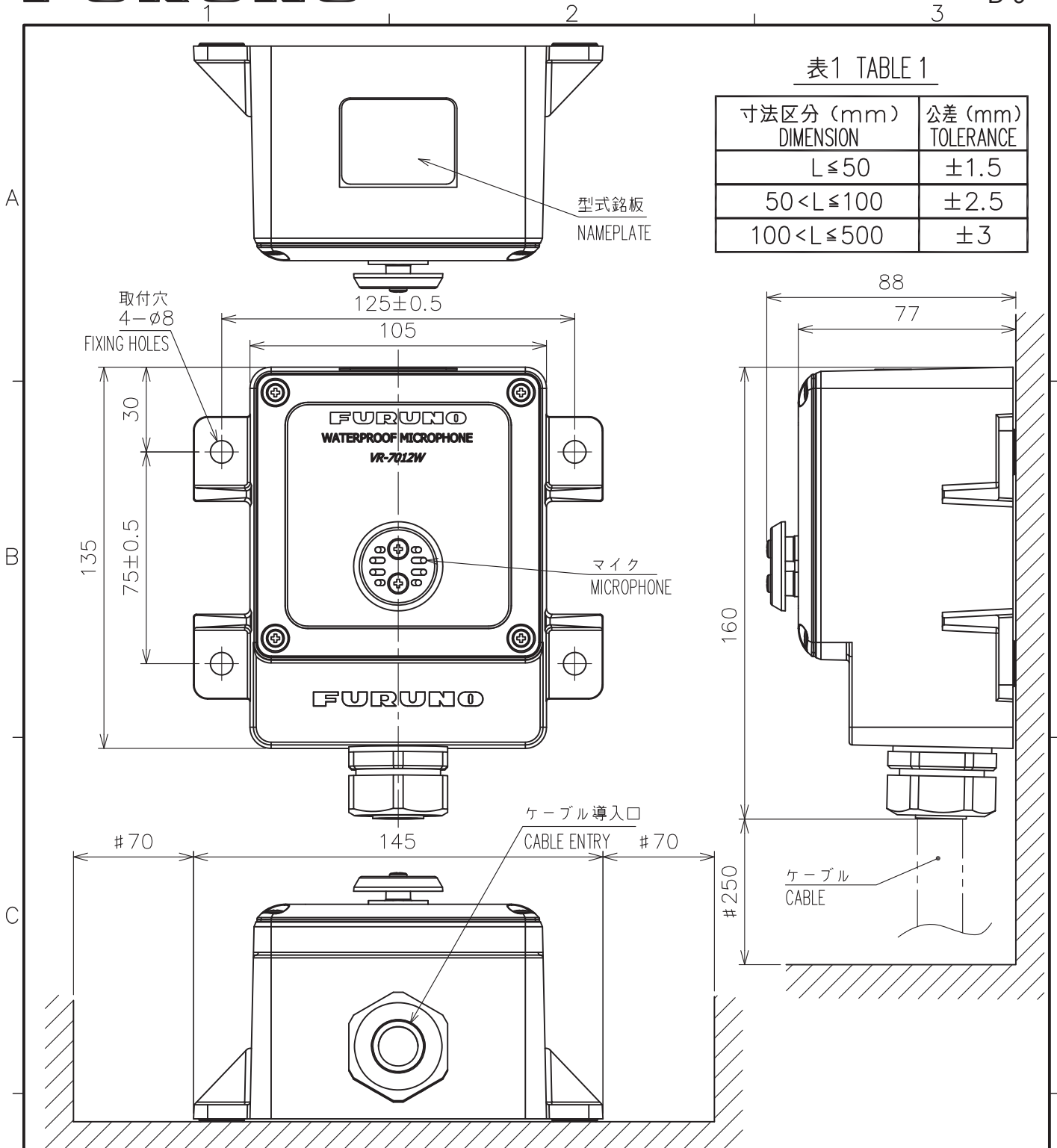

- 注記 1) 指定外の寸法公差は表 1 による。
 2) #印寸法は最小サービス空間寸法とする。
 3) 取付用ネジはトラスタッピンネジ呼び径6×30を使用のこと。
- NOTE 1. TABLE 1 INDICATES TOLERANCE OF DIMENSIONS WHICH IS NOT SPECIFIED.
 2. #: MINIMUM SERVICE CLEARANCE.
 3. USE TAPPING SCREWS $\phi 6 \times 30$ FOR FIXING THE UNIT.

DRAWN	4/Sep/2014	T.YAMASAKI	TITLE	VR-7012W
CHECKED	4/Sep/2014	H.MAKI	名称	防水マイクロフォン (壁掛装備)
APPROVED	4/Sep/2014	H.MAKI		外寸図
SCALE	1/2	MASS 0.62 $\pm 10\%$ kg	質量はケーブルを含まず。 MASS DOES NOT INCLUDE CABLE.	NAME
DWG. No.	C4485-G05-C	REF. No.	24-015-410G-1	WATERPROOF MICROPHONE (BULKHEAD MOUNT)
				OUTLINE DRAWING

表 1 TABLE 1

寸法区分 (mm) DIMENSION	公差 (mm) TOLERANCE
$L \leq 50$	± 1.5
$50 < L \leq 100$	± 2.5
$100 < L \leq 500$	± 3

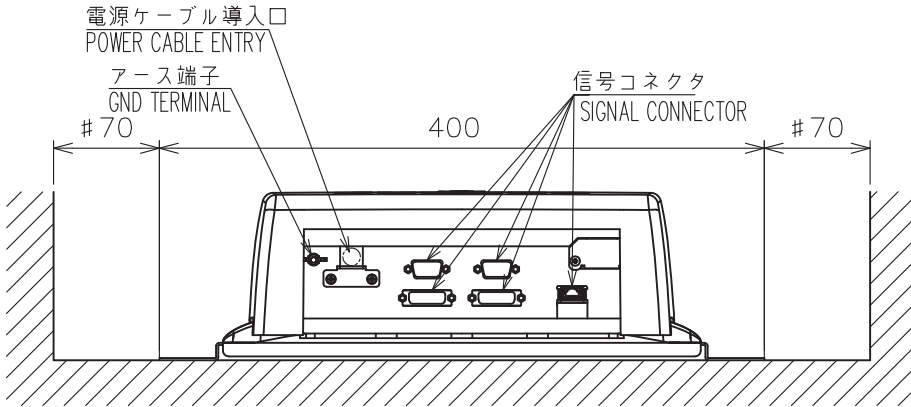
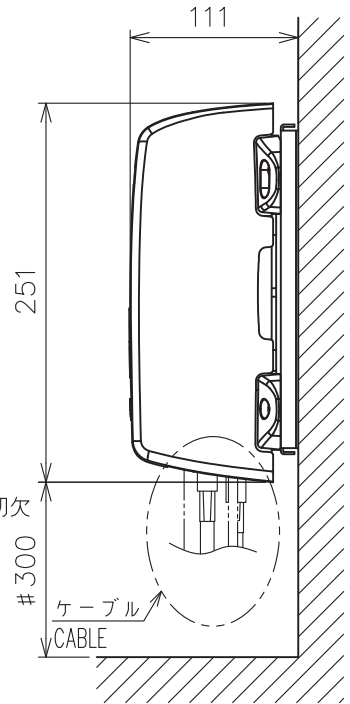
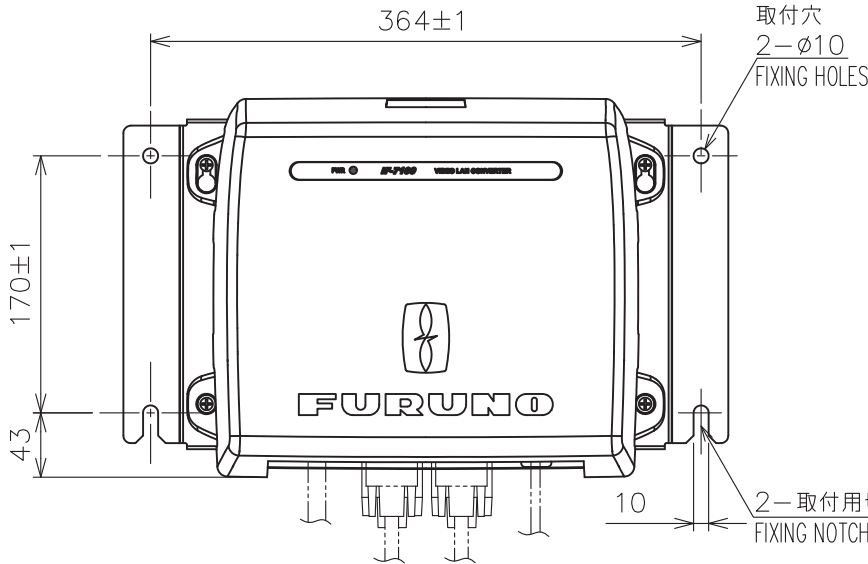
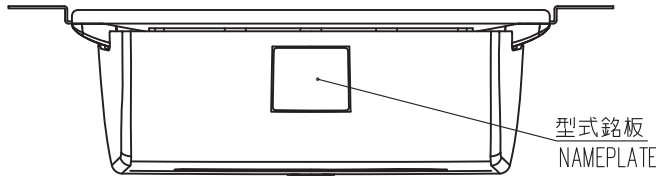

- 注 記 1) 指定外の寸法公差は表 1 による。
2) # 印寸法は最小サービス空間寸法とする。
3) 取付ネジは M8 ボルトとする。

- NOTE 1. TABLE 1 INDICATES TOLERANCE OF DIMENSIONS WHICH IS NOT SPECIFIED.
2. #: MINIMUM SERVICE CLEARANCE.
3. USE M8 BOLTS FOR FIXING THE UNIT.

DRAWN	18/Jun/2014 T.YAMASAKI	TITLE	IF-7100
CHECKED	18/Jun/2014 H.MAKI	名称	ビデオLANコンバータ
APPROVED	19/Jun/2014 H.MAKI	VR-7000	外寸図
SCALE	1/5	MASS	3.2 ±10% kg
DWG. No.	C4485-G09-B	REF. No.	24-015-300G-0
		NAME	VIDEO LAN CONVERTER OUTLINE DRAWING

表1 TABLE 1

寸法区分 (mm) DIMENSION	公差 (mm) TOLERANCE
L ≤ 50	±1.5
50 < L ≤ 100	±2.5
100 < L ≤ 500	±3

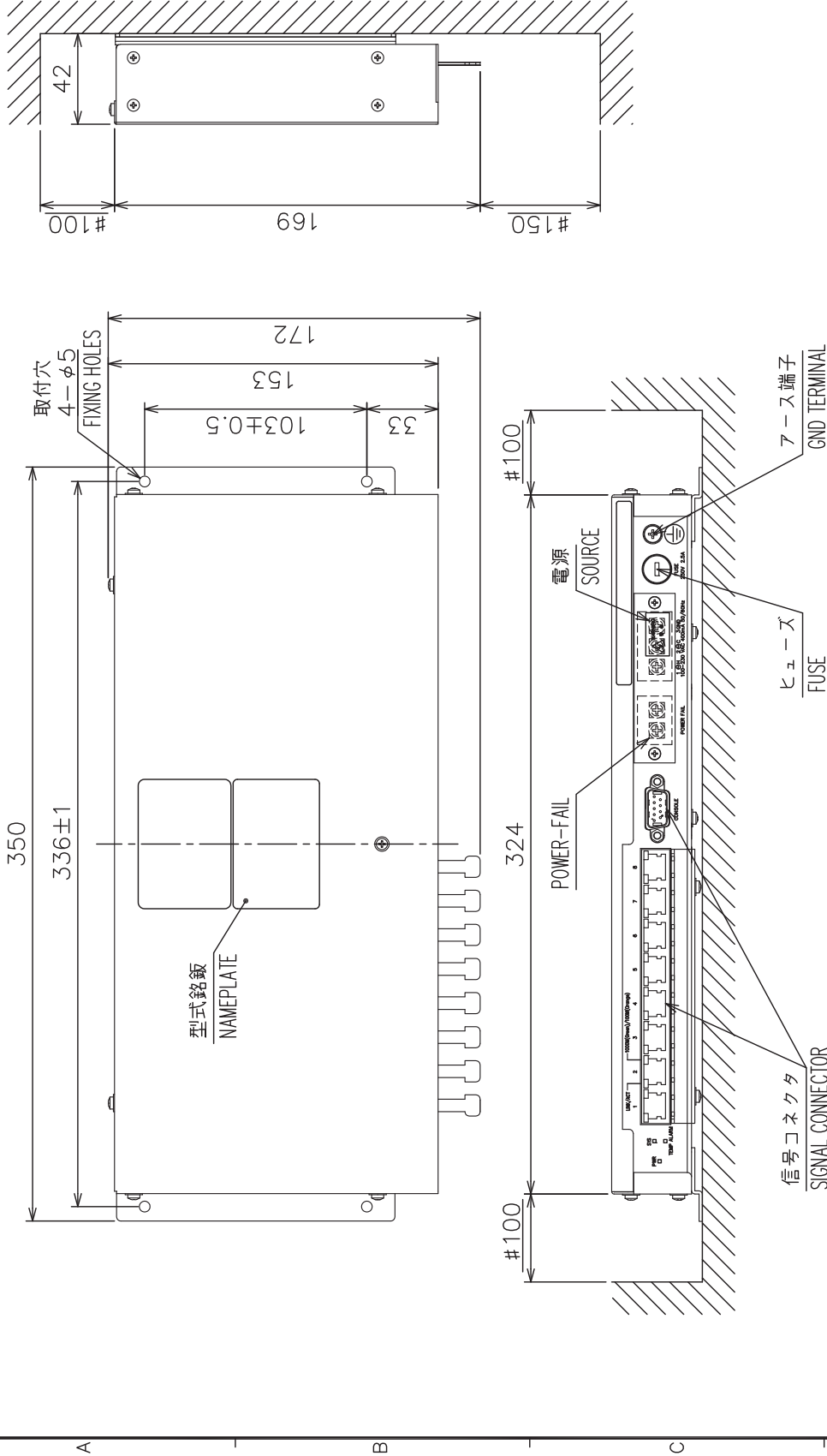

- 注記 1) 指定外の寸法公差は表 1 による。
 2) # 印寸法は最小サービス空間寸法とする。
 3) 取付用ネジはトラスタックピンネジ呼び径 4×20 を使用のこと。
- NOTE 1. TABLE 1 INDICATES TOLERANCE OF DIMENSIONS WHICH IS NOT SPECIFIED.
 2. #. MINIMUM SERVICE CLEARANCE.
 3. USE TAPPING SCREWS φ4x20 FOR FIXING THE UNIT.

DRAWN	8/Jun/2018	I. YAMASAKI	TITLE	HUB-3000
CHECKED	8/Jun/2018	H. MAKI	名称	インテリジェントハブ
APPROVED	8/Jun/2018	H. MAKI	外寸図	
SCALE	1/3	1 MASS ±10% 質量はケーブルを含まず。 MASS DOES NOT INCLUDE CABLE.	NAME	INTELLIGENT HUB
DWG. No.	C4473-G12-C	REF. No.	24-014-350G-2	OUTLINE DRAWING



表1 TABLE 1

寸法区分 (mm) DIMENSION	公差 (mm) TOLERANCE
L ≤ 50	±1.5
50 < L ≤ 100	±2.5
100 < L ≤ 500	±3

- 注記 1) 指定外の寸法公差は表1による。
 2) #印寸法は最小サービス空間寸法とする。
 3) 取付用ネジはトラスタップネジ呼び径4×20を使用のこと。

- NOTE 1. TABLE 1 INDICATES TOLERANCE OF DIMENSIONS WHICH IS NOT SPECIFIED.
 2. #: MINIMUM SERVICE CLEARANCE.
 3. USE TAPPING SCREWS $\phi 4 \times 20$ FOR FIXING THE UNIT.

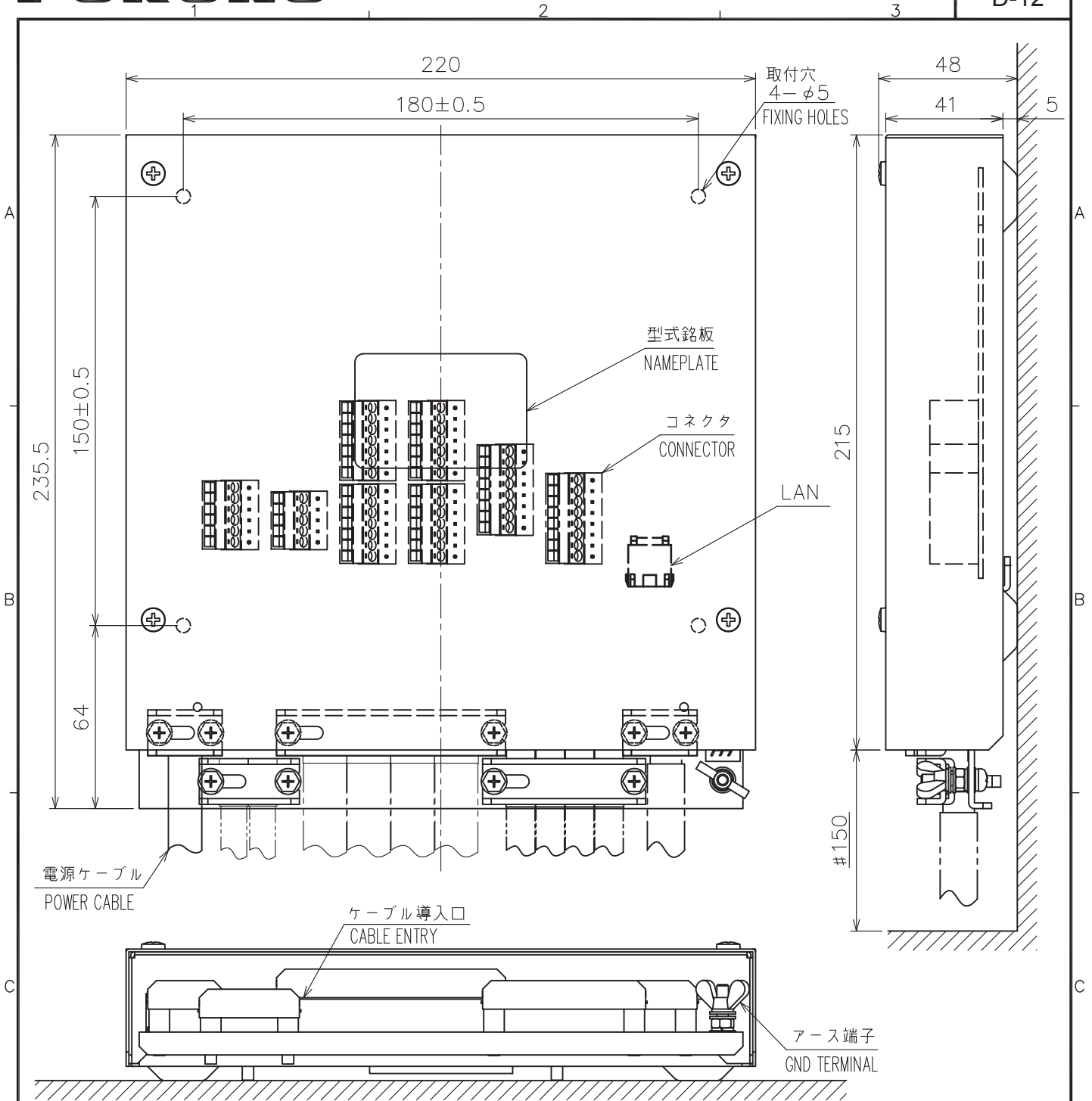
DRAWN 11/Jan/2012 T.YAMASAKI	TITLE MC-3000S
CHECKED 11/Jan/2012 H.MAKI	名称 センサーアダプター (シリアル)
APPROVED 13/Jan/2012 Y.NISHIYAMA	FMD-3200 外寸図
SCALE 1/2	MASS 1.5 ±10% kg 質量はケーブルを含まず。 MASS DOES NOT INCLUDE CABLE.
DWG. No. C4473-G08-A	REF. No. 24-014-200G-1
NAME SENSOR ADAPTER (SERIAL)	
OUTLINE DRAWING	



表1 TABLE 1

寸法区分 (mm) DIMENSION	公差 (mm) TOLERANCE
L ≤ 50	±1.5
50 < L ≤ 100	±2.5
100 < L ≤ 500	±3

- 注記 1) 指定外の寸法公差は表1による。
 2) #印寸法は最小サービス空間寸法とする。
 3) 取付用ネジはトラスタップピンネジ呼び径4×20を使用のこと。

- NOTE 1. TABLE 1 INDICATES TOLERANCE OF DIMENSIONS WHICH IS NOT SPECIFIED.
 2. #: MINIMUM SERVICE CLEARANCE.
 3. USE TAPPING SCREWS Ø4x20 FOR FIXING THE UNIT.

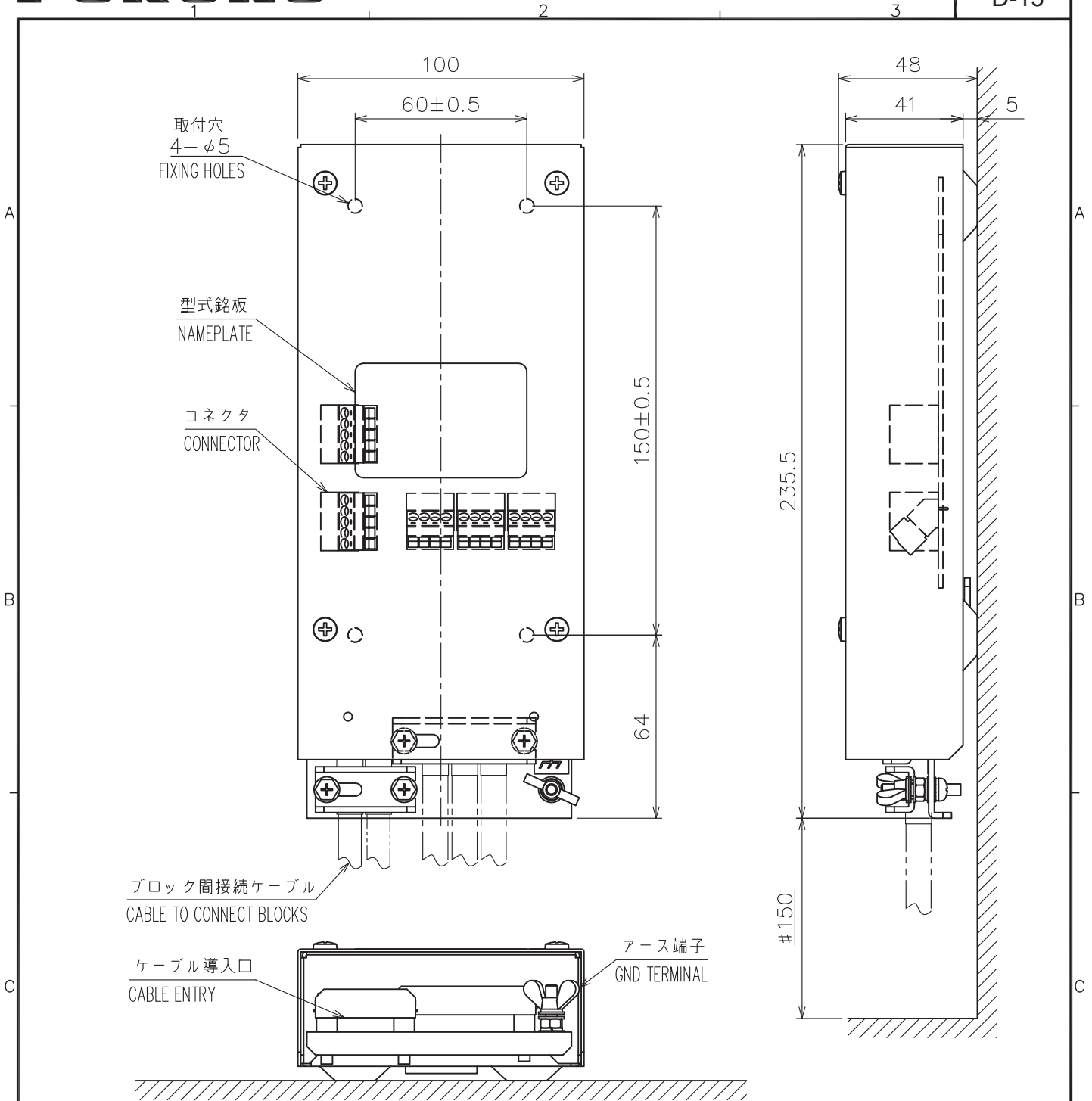
DRAWN 11/Jan/2012 T.YAMASAKI	TITLE MC-3010A
CHECKED 11/Jan/2012 H.MAKI	名称 センサーアダプター (アナログ)
APPROVED 13/Jan/2012 Y.NISHIYAMA	FMD-3200 外寸図
SCALE 1/2	MASS 0.8 ±10% kg
DWG. No. C4473-G09-A	REF. No. 24-014-210G-1
質量はケーブルを含まず。 MASS DOES NOT INCLUDE CABLE.	
NAME SENSOR ADAPTER (ANALOG)	
OUTLINE DRAWING	



表1 TABLE 1

寸法区分 (mm) DIMENSION	公差 (mm) TOLERANCE
L ≤ 50	±1.5
50 < L ≤ 100	±2.5
100 < L ≤ 500	±3

- 注記 1) 指定外の寸法公差は表1による。
 2) #印寸法は最小サービス空間寸法とする。
 3) 取付用ネジはトラスタップピンネジ呼び径4×20を使用のこと。

- NOTE 1. TABLE 1 INDICATES TOLERANCE OF DIMENSIONS WHICH IS NOT SPECIFIED.
 2. #: MINIMUM SERVICE CLEARANCE.
 3. USE TAPPING SCREWS Ø4x20 FOR FIXING THE UNIT.

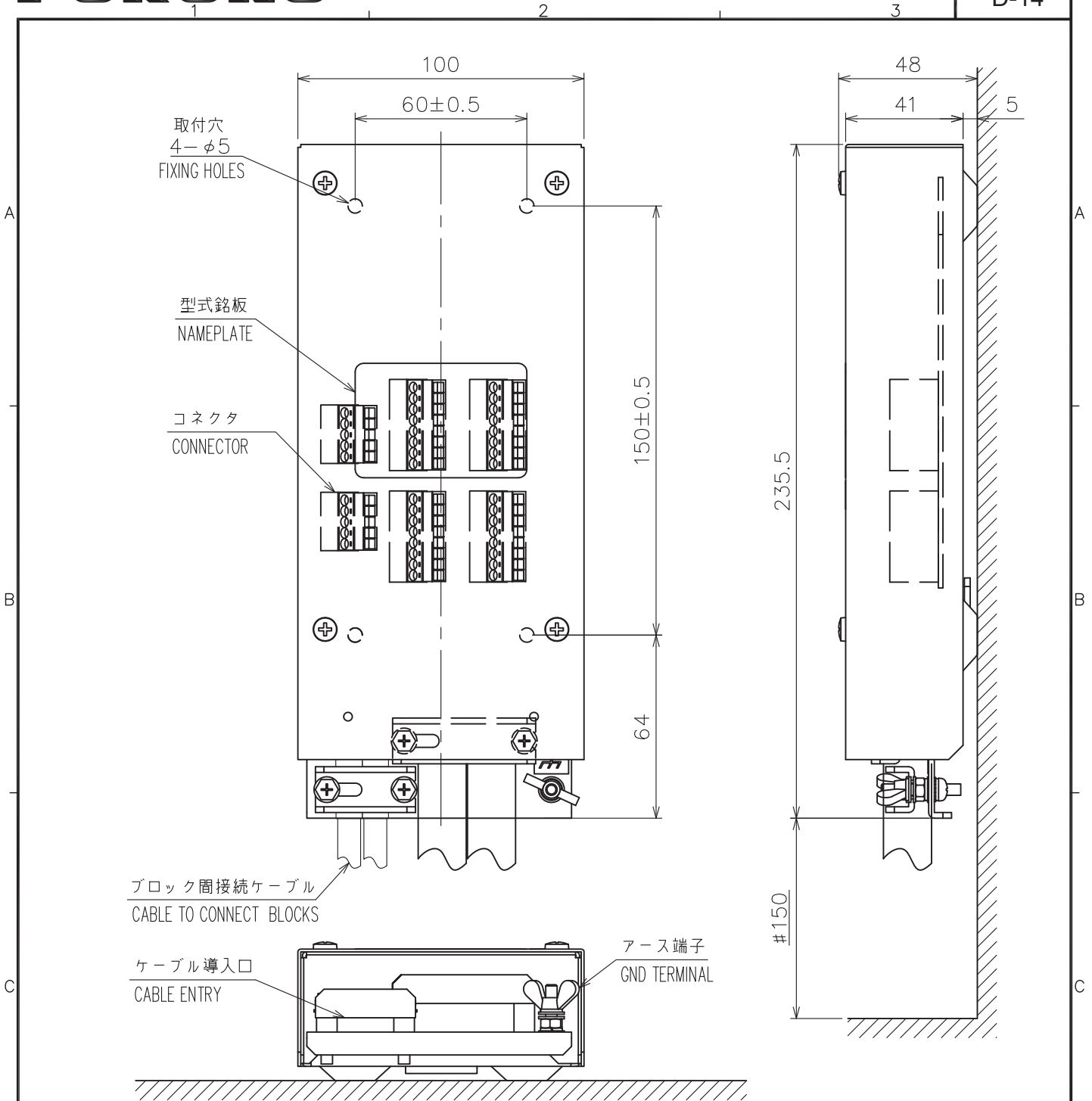
DRAWN 11/Jan/2012 T.YAMASAKI	TITLE MC-3020D
CHECKED 11/Jan/2012 H.MAKI	名称 センサーアダプター (デジタルイン)
APPROVED 13/Jan/2012 Y.NISHIYAMA	FMD-3200 外寸図
SCALE 1/2	MASS 0.8 ±10% kg
DWG. No. C4473-G10-A	REF. No. 24-014-220G-1
質量はケーブルを含まず。 MASS DOES NOT INCLUDE CABLE.	
NAME SENSOR ADAPTER (DIGITAL IN)	
OUTLINE DRAWING	



表 1 TABLE 1

寸法区分(mm) DIMENSION	公差(mm) TOLERANCE
0 < L ≤ 50	±1.5
50 < L ≤ 100	±2.5
100 < L ≤ 500	±3

- 注 記 1) 指定外の寸法公差は表 1 による。
 2) #印寸法は最小サービス空間寸法とする。
 3) 取付用ネジは M8 ボルトを使用のこと。

- NOTE 1. TABLE 1 INDICATES TOLERANCE OF DIMENSIONS WHICH IS NOT SPECIFIED.
 2. #: MINIMUM SERVICE CLEARANCE.
 3. USE M8 BOLTS FOR FIXING THE UNIT.

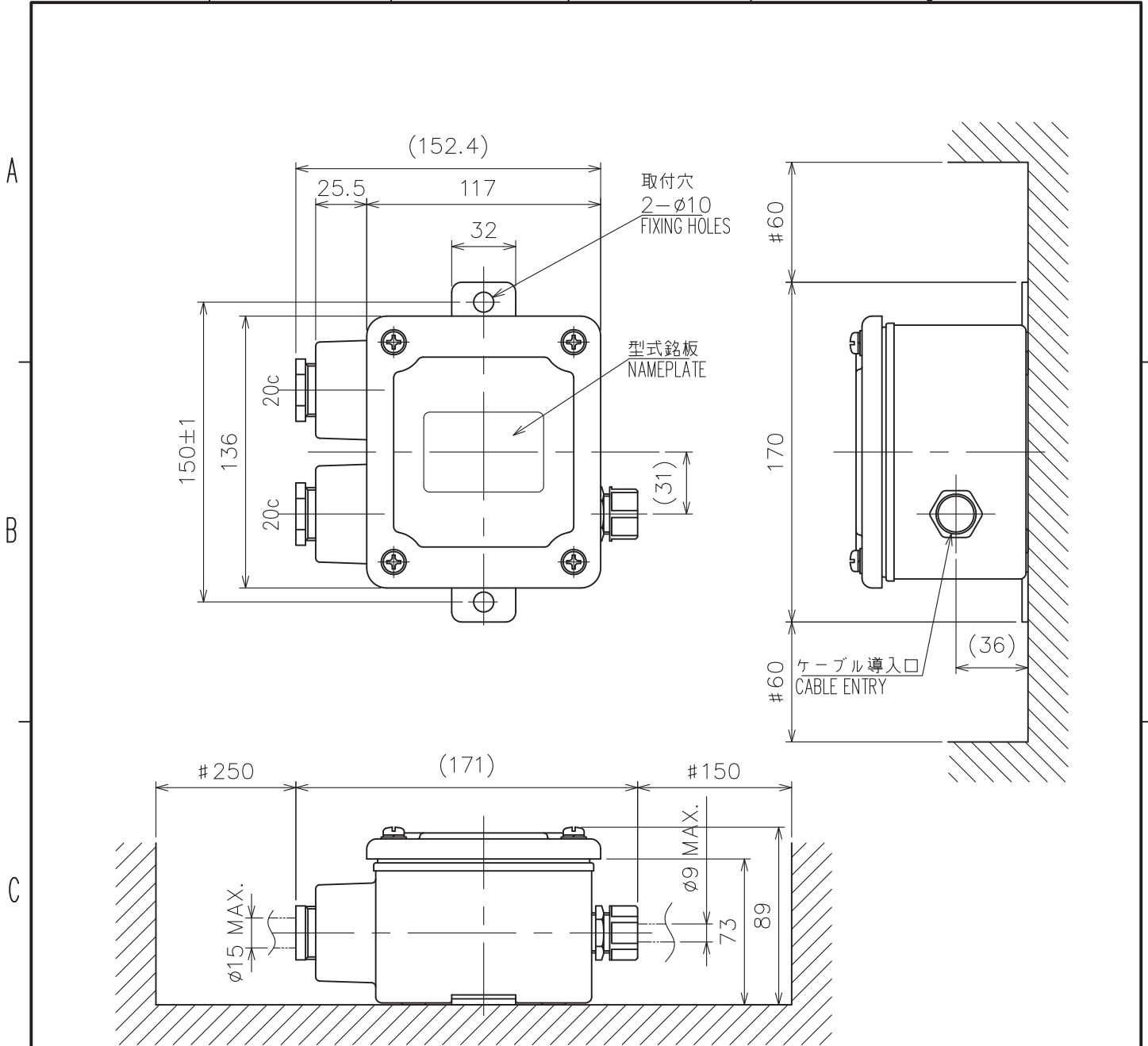
DRAWN 29/Oct/2014 T.YAMASAKI		TITLE VR-7022F
CHECKED 29/Oct/2014 H.MAKI		名称 ジャンクションボックス
APPROVED 29/Oct/2014 H.MAKI	VR-7000	外寸図
SCALE 1/2	MASS 1.5 ±10% kg	NAME JUNCTION BOX
DWG.No. C4485-G11-G	REF.No. 24-015-432G-3	OUTLINE DRAWING

表1 TABLE 1

寸法区分 (mm) DIMENSIONS	公差 (mm) TOLERANCE
$L \leq 50$	± 1.5
$50 < L \leq 100$	± 2.5
$100 < L \leq 500$	± 3

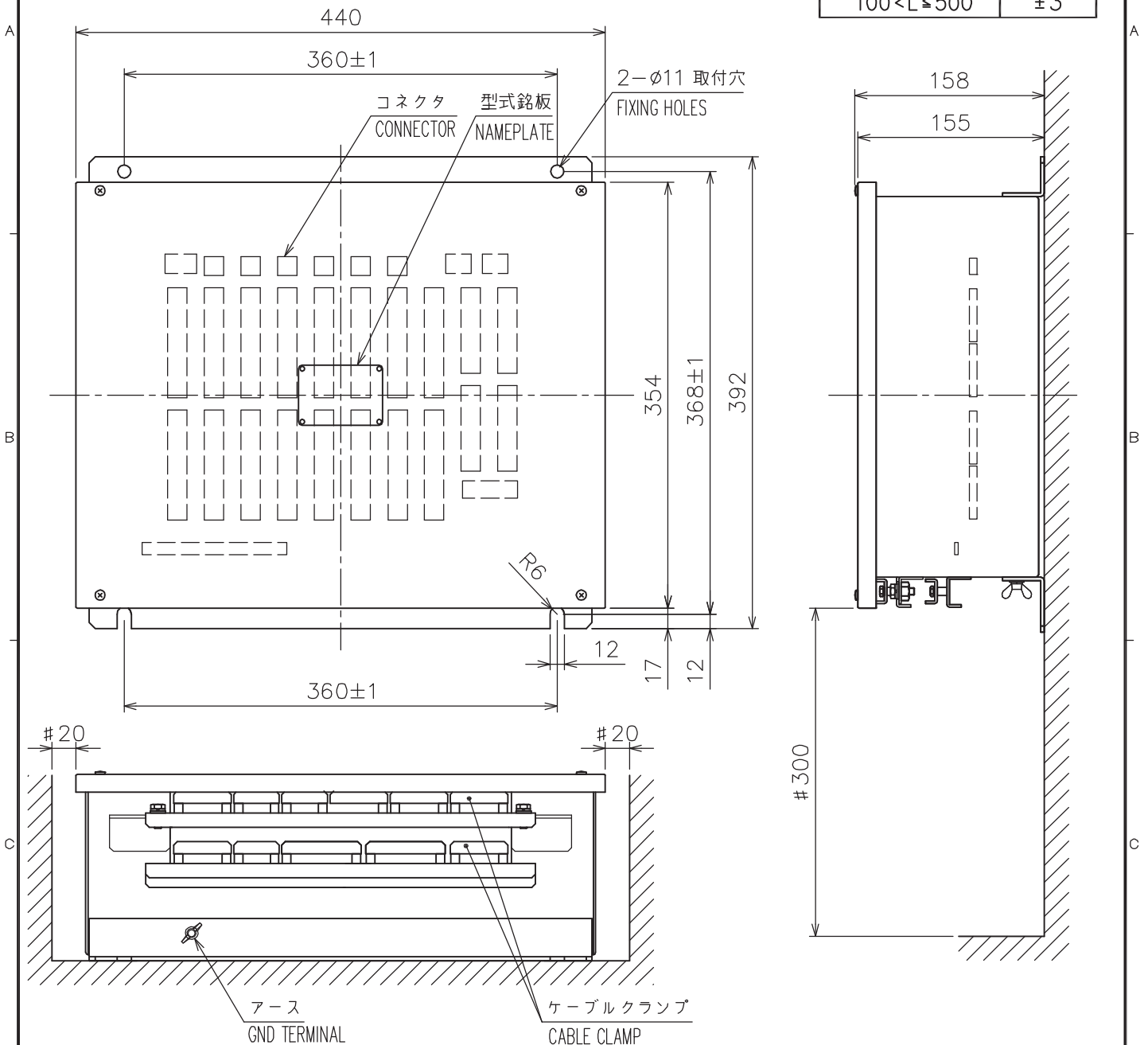

- 注 記 1) #印寸法は最小サービス空間寸法とする。
 2) 指定外の寸法公差は表1による。
 3) 取付にはM10ボルトまたはコーチボルト呼び10を使用のこと。

- NOTE 1. #: MINIMUM SERVICE CLEARANCE.
 2. TABLE 1 INDICATES TOLERANCE OF DIMENSIONS WHICH IS NOT SPECIFIED.
 3. USE M10 BOLTS OR COACH BOLTS φ10 FOR FIXING THE UNIT.

DRAWN	Apr. 27, '06 E.MIYOSHI	TITLE	IF-8530
CHECKED	TAKAHASHI.T	名称	接続箱
APPROVED	Y.Hatai	外寸図	
SCALE	1/5	MASS	13.0 ±10% kg
DWG.No.	C4437-G03-C	REF.No.	24-009-300G-3
		NAME	JUNCTION BOX
		OUTLINE DRAWING	

表 1 TABLE 1

寸法区分 (mm) DIMENSIONS	公差 (mm) TOLERANCE
$L \leq 50$	± 1.5
$50 < L \leq 100$	± 2.5
$100 < L \leq 500$	± 3

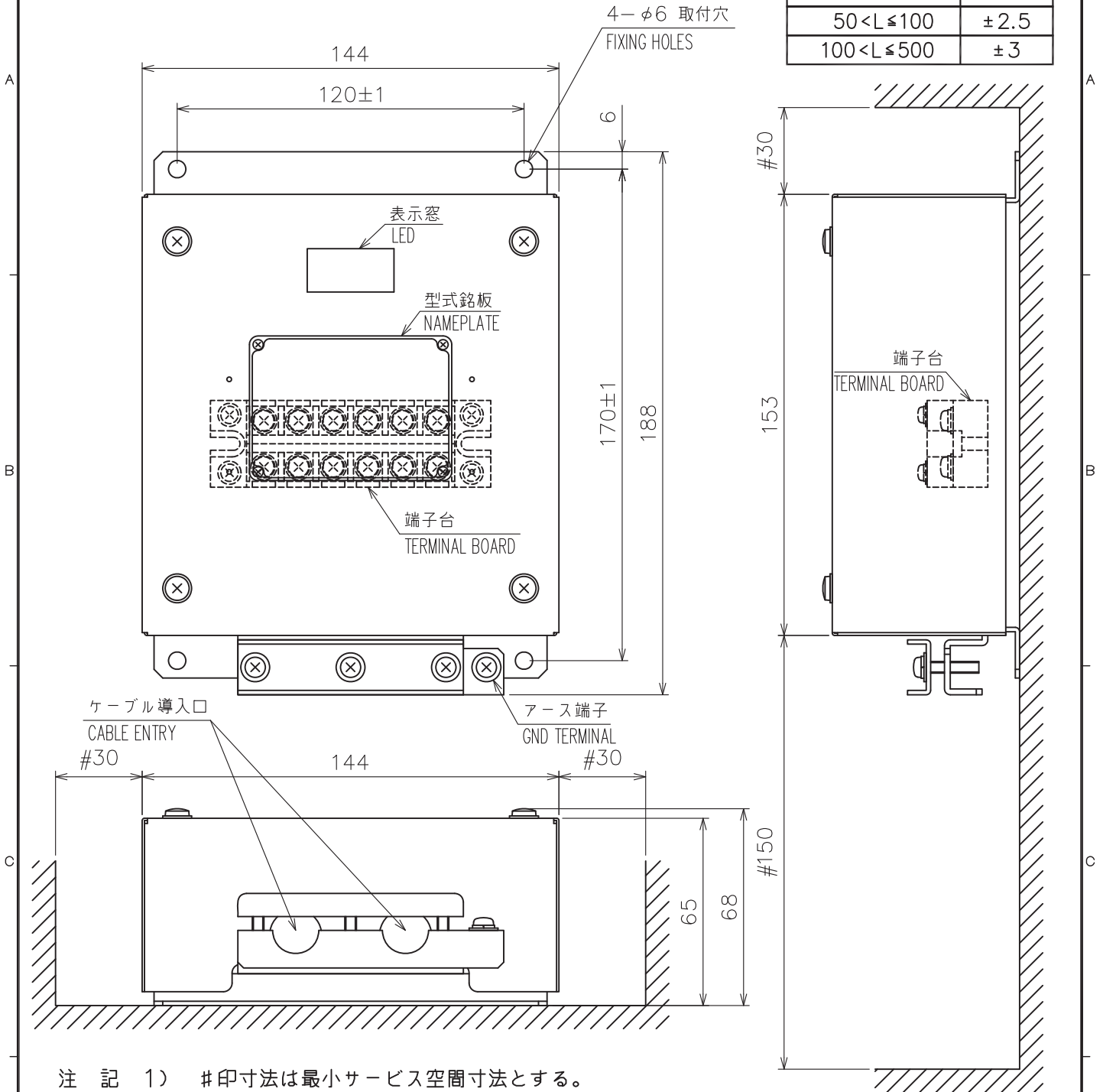

- 注 記 1) #印寸法は最小サービス空間寸法とする。
 2) 指定外の寸法公差は表 1 による。
 3) 取付用ネジはトラスタップピンネジ呼び径5×20を使用のこと。

- NOTE 1. #: MINIMUM SERVICE CLEARANCE.
 2. TABLE 1 INDICATES TOLERANCE OF DIMENSIONS WHICH IS NOT SPECIFIED.
 3. USE SELF-TAPPING SCREWS 5x20 FOR FIXING THE UNIT.

DRAWN Dec. 5, '06	E. MIYOSHI	TITLE PSU-011
CHECKED	TAKAHASHI, T	名称 電源制御部
APPROVED	Y. Hatai	FAR-2827W
SCALE 1/2	MASS 0.59 $\pm 10\%$ kg	NAME POWER SUPPLY UNIT
DWG.No. C3527-G06-A	REF.No. 03-154-900G-0	OUTLINE DRAWING

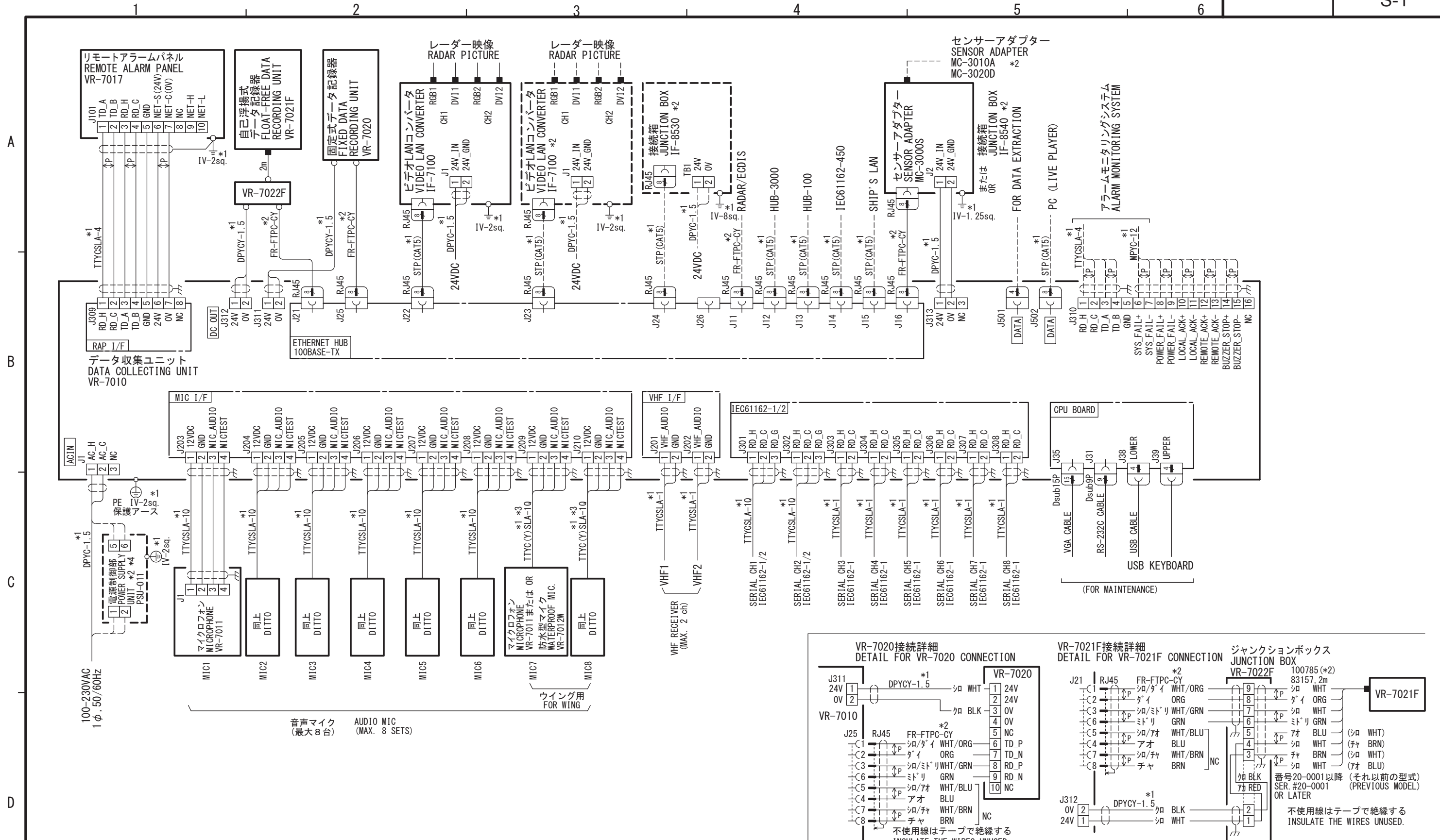

各信号の接続に関しては造船所/船主との事前打合せが必要です。
CONSULT WITH SHIPOWNER AND/OR SHIPYARD ABOUT CONNECTION OF DEVICES.

- 注記 NOTE
- * 1) 造船所手配
 - * 2) オプション
 - * 3) 防水型にはTTYCYSLAを使用。
 - * 4) ロシア型検仕様のみ。
- NOTE
- *1: SHIPYARD SUPPLY.
 - *2: OPTION.
 - *3: USE TTYCYSLA CABLE FOR WATERPROOF MIC.
 - *4: FOR RUSSIAN FLAG VESSELS ONLY.

DRAWN	7/Nov/2017 I. YAMASAKI	TITLE	VR-7000
CHECKED	7/Nov/2017 H. MAKI	名称	航海情報記録装置
APPROVED	9/Nov/2017 H.MAKI	相互結線図	
SCALE	MASS kg	NAME	VOYAGE DATA RECORDER
DWG No.	C4485-C01- M	REF. No.	
		INTERCONNECTION DIAGRAM	

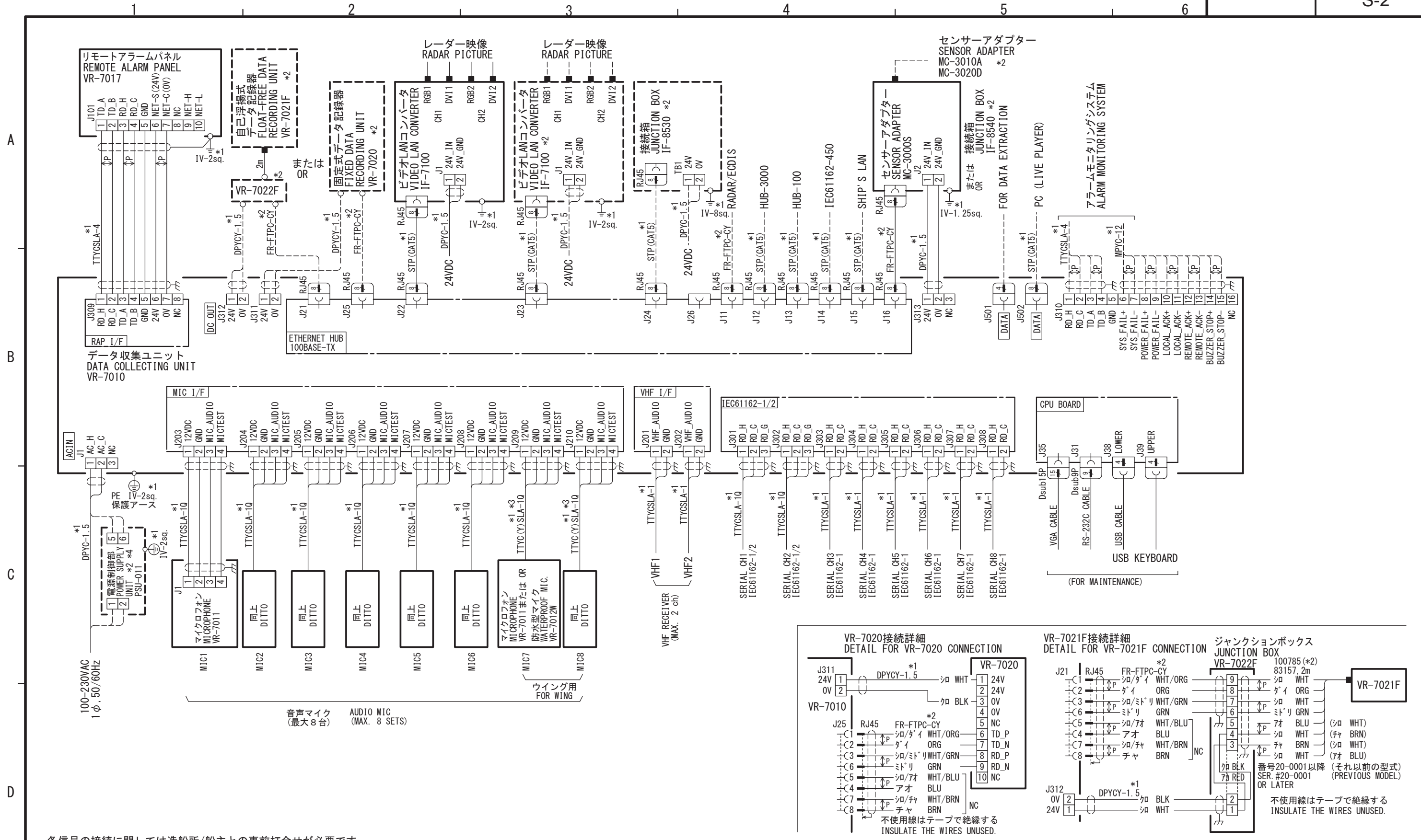

各信号の接続に関しては造船所/船主との事前打合せが必要です。
CONSULT WITH SHIPOWNER AND/OR SHIPYARD ABOUT CONNECTION OF DEVICES.

- 注記 NOTE
- * 1) 造船所手配 *1: SHIPYARD SUPPLY.
 - * 2) オプション *2: OPTION.
 - * 3) 防水型にはTTYCYSLAを使用。 *3: USE TTYCYSLA CABLE FOR WATERPROOF MIC.
 - * 4) ロシア型検仕様のみ。 *4: FOR RUSSIAN FLAG VESSELS ONLY.

DRAWN	8/Nov/2017 I. YAMASAKI	TITLE	VR-7000S
CHECKED	8/Nov/2017 H. MAKI	名称	簡易型航海情報記録装置
APPROVED	9/Nov/2017 H. MAKI	相互結線図	
SCALE	MASS kg	NAME	SIMPLIFIED VOYAGE DATA RECORDER
DWG No.	C4495-C01-C	REF. No.	INTERCONNECTION DIAGRAM

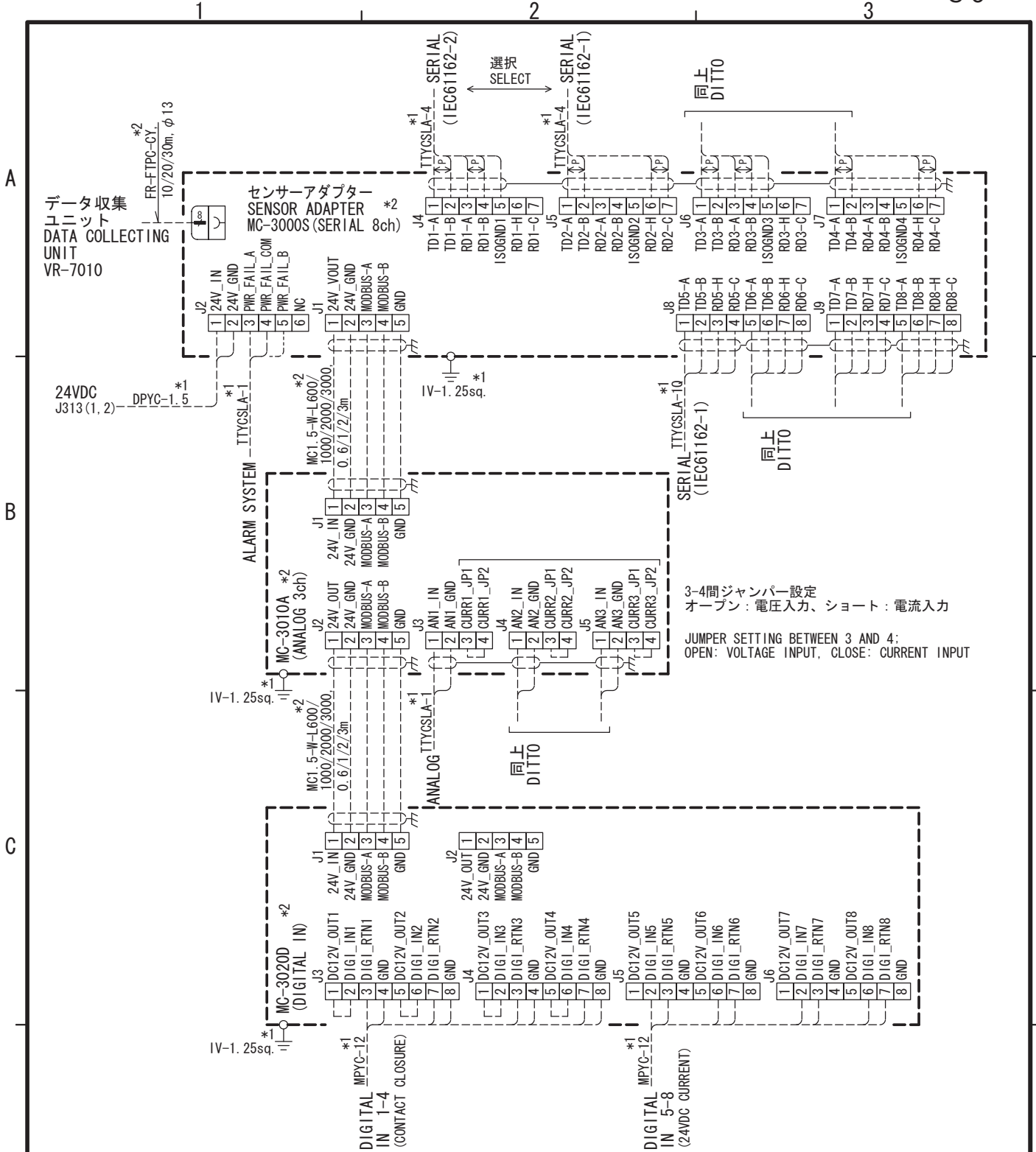

DRAWN 9/Apr/2014 T. YAMASAKI	TITLE MC-3000S/3010A/3020D
CHECKED 14/Apr/2014 H. MAKI	名称 センサーアダプター
APPROVED 21/Apr/2014 H. MAKI	相互結線図
SCALE MASS kg	NAME SENSOR ADAPTER
DWG. No. C4485-C02- B	REF. No. 24-014-6003-2
INTERCONNECTION DIAGRAM	

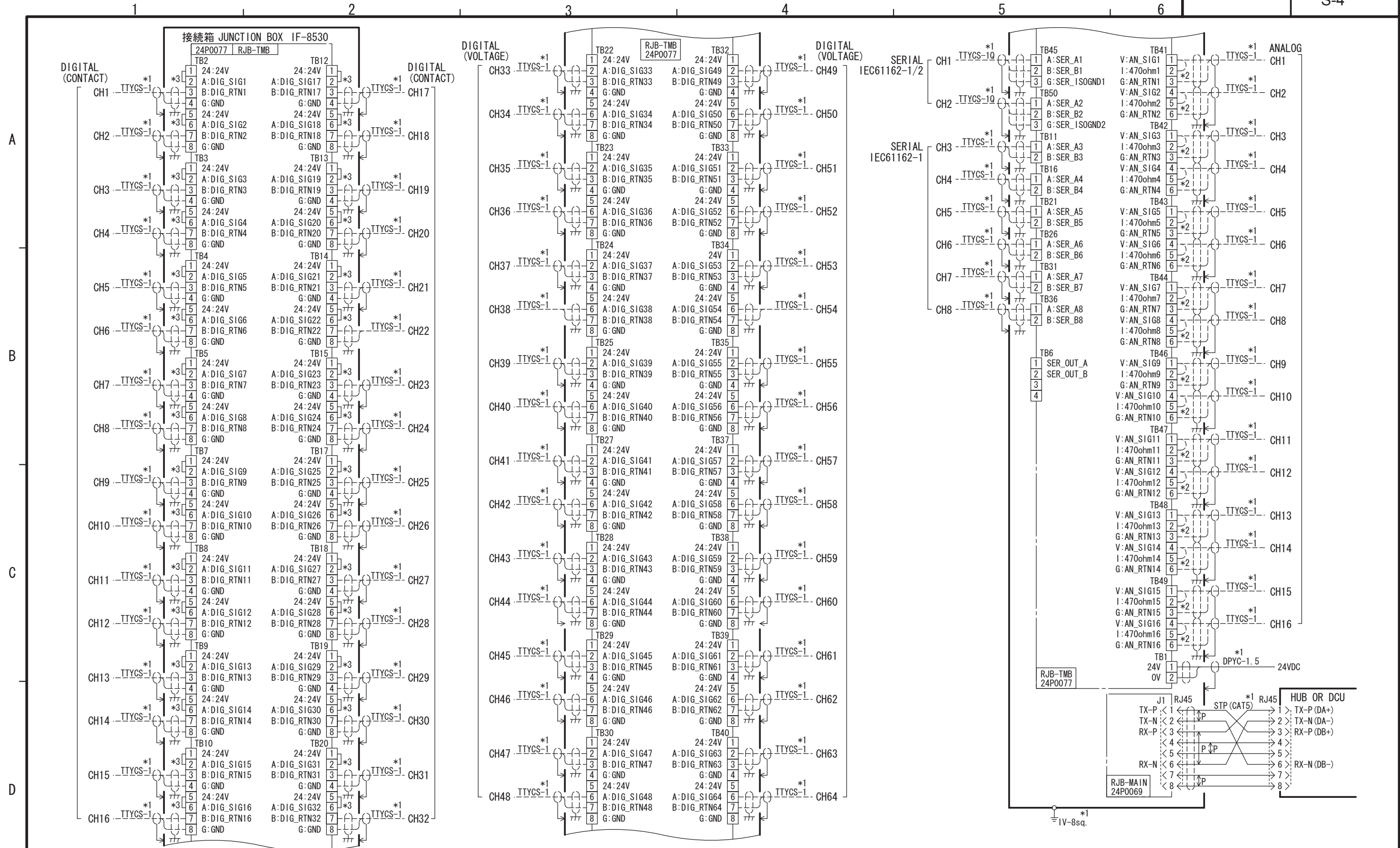

各信号の接続に関しては造船所/船主との事前打合せが必要です。
 注記
 * 1) 造船所手配。
 * 2) 入力信号が4-20mAの場合はV-I間をショートすること。
 * 3) 接点信号接続用に24V-A端子間にジャンパー取付済。
 電圧信号接続時は設定を変更する。

CONSULT WITH SHIPOWNER AND/OR SHIPYARD ABOUT CONNECTION OF DEVICES.
 NOTE
 *1: SHIPYARD SUPPLY.
 *2: SET JUMPER BETWEEN I AND V FOR 4-20mA SIGNAL.
 *3: JUMPER SET BETWEEN 24V AND A-TERMINAL AT FACTORY.
 MODIFY SETTING TO CONNECT A VOLTAGE LINE.

DRAWN	18/Jun/2014 T. YAMASAKI	TITLE	IF-8530
CHECKED	18/Jun/2014 H. MAKI	名称	接続箱
APPROVED	19/Jun/2014 H. MAKI	相互結線図	
SCALE	MASS kg	NAME	JUNCTION BOX
DWG No.	C4437-C02- K	INTERCONNECTION DIAGRAM	